

White Paper

Adding Capacity Cost-Effectively to the Mobile Network with Bandwidth Optimization

Adding Capacity Cost-Effectively to the Mobile Network with Bandwidth Optimization

White Paper

Executive Summary

The popularity of the Blackberry and smartphones, such as the iPhone, are forcing mobile service providers to consider how best to meet the growing demands for rich data services that are straining mobile network capacity and eroding profits. Because their networks were originally designed for the low bandwidth requirements of voice traffic, mobile providers today have only a limited set of options for increasing capacity to accommodate data services. Most of these options are expensive and often time-consuming to deploy, and include adding more leased lines, moving to fiber, increasing the microwave spectrum, and using Ethernet ring.

Optimizing the backhaul segment of a mobile network is another option, but a far less expensive one, which is also very easy to deploy quickly. This paper will describe mobile backhaul optimization and will use the Dialogic® I-Gate® 4000 Session Bandwidth Optimizer Mobile Backhaul as a concrete example. Such an option can provide a cost-effective approach to today's bandwidth dilemma and a strategy for increasing profits. It allows mobile providers to accommodate the growing demands of advanced users for rich data services while they continue to deliver excellent and reliable service to subscribers at all levels of sophistication.

Table of Contents

Move from Voice to Data Services Requires Increased Bandwidth	2
Meeting Increasing Demand with Network Investment	2
Mobile Backhaul and TDM	3
Evaluating the Traditional Choices for Scaling Mobile Backhaul	3
Optimizing Mobile Backhaul: A Specific Example	4
How Mobile Backhaul Optimization Works	5
Additional Benefits	6
Forecasting Mobile Backhaul Optimization Benefits	6
Acronyms	7

Move from Voice to Data Services Requires Increased Bandwidth

Mobile service providers worldwide have seen unprecedented subscriber growth in the last 15 years. In the first decade of this growth, per capita bandwidth consumption was low, since voice was the predominant service and could be accommodated without too much difficulty and expense. But between 2005 and 2010, the situation changed radically— voice ARPU began to decline, competition became intense among providers, and bandwidth-hungry data services were introduced.

At first, mobile providers looked to new services that did not require a lot of additional bandwidth to boost ARPU. Short Message Service (SMS) was one of the first non-voice service offerings, and it was very well received. Like voice, SMS is a low-bandwidth service, and scaling a network to accommodate its popularity simply meant adding modest amounts of capacity to current mobile networks, especially at times of peak demand.

As early as 2000, data services were introduced with the advent of GPRS and CDMA 1xRTT technologies, but voice-centric handsets limited the type of data services that could be offered to most subscribers. With the introduction of the Blackberry, email service on the handset gradually became popular, first among business users and then with the general public.

The introduction of the smartphone, beginning with Apple's iPhone in 2007, brought sophisticated data services, such as mobile internet and video, and a new type of handset. The higher bandwidth requirements for these new rich data services left mobile service providers scrambling to roll out 3G technologies that supported the significantly higher bandwidth required for an enhanced user experience.

Meeting Increasing Demand with Network Investment

As a veritable flood of clever iPhone apps become available and with the advent of data-hungry Android-based smartphones in 2010, very sophisticated data services, such as video conferencing, video streaming, rich media mobile advertising, and other high-end services, began to make unprecedented demands on mobile networks.

Although mobile service providers are counting on broadband services for increased ARPU, smartphone popularity comes at a very high price. Smartphone data services require mobile networks to handle substantially higher bandwidth than voice and SMS services, adding significantly to operational costs. To deliver rich data services, mobile service providers may consider upgrading radio technologies, the backhaul segment between the radio towers and base station controllers, and/or core network segments. Strategies can include;

- **Increasing bandwidth** — Moving to 3G HSPA or an LTE network or WiFi offload
- **Expanding coverage** — Adding more radio towers and/or fiber
- **Implementing a more efficient and optimized network** — Revising current pricing plans or bandwidth optimization

This paper will explain how the mobile backhaul segment can become a key component in meeting increased demand, improving network performance, and reducing OPEX/CAPEX to increase profits from mobile broadband services quickly and cost-effectively. Figure 1 illustrates the placement of a backhaul segment.

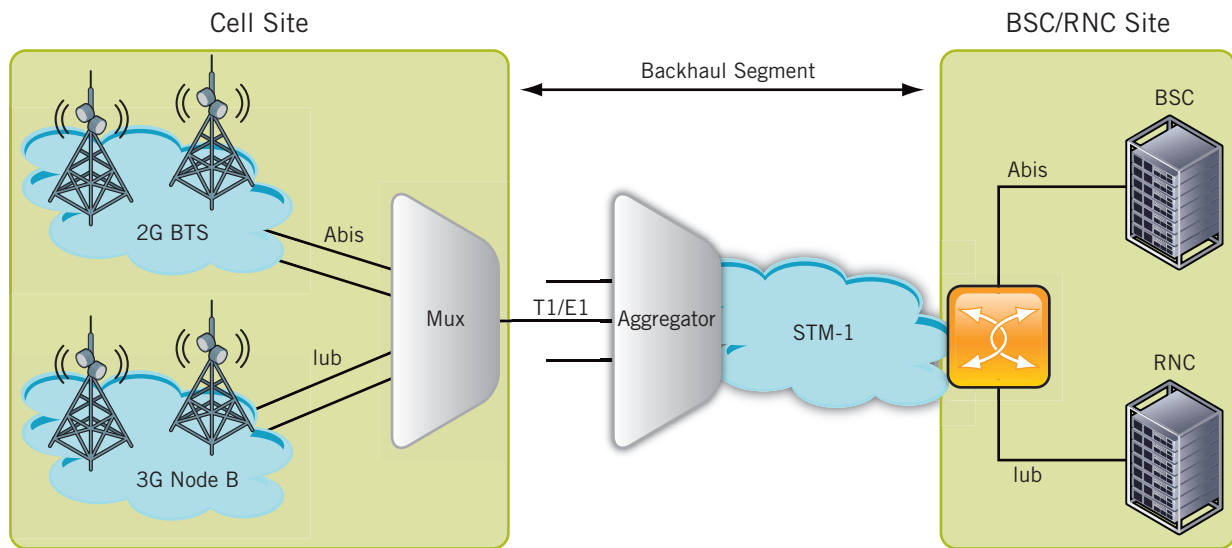

Figure 1. Backhaul in the Mobile Network

This paper will also describe an example of a specific strategy that uses a Dialogic® I-Gate® 4000 Session Bandwidth Optimizer Mobile Backhaul (I-Gate 4000 SBO MB) to optimize the mobile backhaul segment.

Mobile Backhaul and TDM

Mobile backhaul segments were originally built on TDM transport technologies because the segments had to meet the stringent requirements for voice services — low latency and jitter with high availability. Generally, TDM delivers far more in these areas than a mobile network requires.

Although the UMTS specifications published in 2008 called for native Ethernet interface support on cell towers, cell sites worldwide generally continue to have native T1/E1 interfaces with cell towers and base stations. Traditionally, backhaul segments use copper or fiber leased lines or microwave to transport the TDM traffic. Physical transport choice depends on capacity, cost, terrain, distance, and regulatory factors in different parts of the world.

Evaluating the Traditional Choices for Scaling Mobile Backhaul

Mobile service providers generally have five alternatives when they wish to scale a backhaul segment to accommodate a surge in data usage.

- **Add more leased capacity to existing copper or fiber lines — very expensive**

Leased-line charges are costly for mobile service providers, and usually are their largest operational expense. Because leased lines are very expensive, they are normally not the first choice for adding capacity to satisfy significantly increased data usage from a growing number of subscribers.

- **Roll out fiber— very expensive and may not be feasible in some areas**

The bandwidth gained from adding fiber optic cable is virtually unlimited, but the capital expenditure in doing so is extremely high. In addition, deploying fiber in some densely populated urban areas may be impractical and very costly in rural areas. Even when feasible, deploying fiber can take a very long time.

- **Increase microwave spectrum — scarce commodity and high fees**

Increasing the microwave spectrum can add 30% in bandwidth capacity, but spectrum can be a scarce commodity in urban areas and in many regions of the world. The cost of deployment can also be high due to mandatory license fees.

- **Upgrade the SDH microwave to Ethernet ring — requires proper conditions**

Upgrading the SDH microwave to Ethernet ring can double capacity, but the correct deployment situation is difficult to achieve. Ethernet ring requires a complex modulation scheme of 256 QAM, which works only in clear weather and over short distances. Even when feasible, both capital and operational expenses for this option are significant and can sometimes be very high. In addition, an upgrade can typically take several months in urban areas.

- **Optimize bandwidth for Abis and lub streams — increases capacity quickly**

Optimizing bandwidth for the Abis and lub streams is a very attractive option for scaling mobile backhaul capacity for several reasons. Optimizing the mobile backhaul segment can typically double the bandwidth capacity at a significantly lower capital and operational cost than the other options discussed in this paper. Deployment also typically takes only a few days.

Optimizing Mobile Backhaul: A Specific Example

Using an I-Gate 4000 SBO MB can provide a very effective (and cost-effective) strategy for optimizing the backhaul segment of a mobile network. See Figure 2 for an illustration of how the I-Gate 4000 SBO MB is placed in a mobile network.

The I-Gate 4000 SBO MB is a standalone system that can optimize bandwidth in the backhaul segments of both 2G (Abis) and 3G (lub) streams (ATM and IP-based). Because it is an option based on units placed within the current physical backhaul segment, it is not as disruptive or costly as other alternatives for increasing bandwidth capacity, such as adding expensive leased lines, deploying fiber, adding microwave spectrum, or moving to Ethernet ring.

The I-Gate 4000 SBO MB monitors and maintains the key performance indicators (KPI) by which mobile backhaul infrastructure performance are measured. These include delay, jitter, bit error rate, and availability. Adherence to prescribed KPIs is critical to maintaining high subscriber quality of experience (QoE) and to meeting Service Level Agreements (SLAs) for voice and data services.

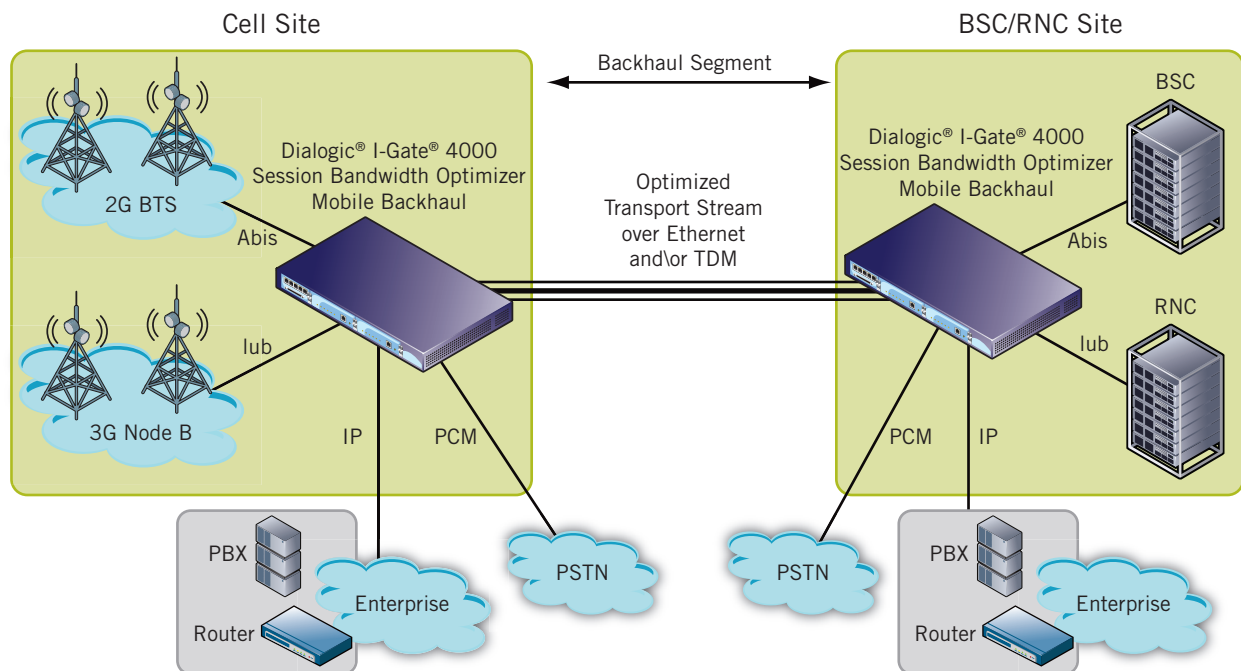

Figure 2. Dialogic® I-Gate® 4000 Session Bandwidth Optimizer Mobile Backhaul Optimizing Various Streams in the Backhaul Segment of a Mobile Network

How Mobile Backhaul Optimization Works

The I-Gate 4000 SBO MB leverages advanced bandwidth optimization, statistical multiplexing, and grooming techniques developed by Dialogic that have been shown to typically double the capacity on backhaul links while preserving the quality and integrity of the original data traffic. By combining sophisticated optimization with Quality of Service (QoS) protection techniques, the I-Gate 4000 SBO MB can provide powerful CAPEX and OPEX savings for a mobile operator's backhaul segment while increasing backhaul capacity.

On the input end, an I-Gate 4000 SBO MB optimizes 2G, 3G, native IP, or PCM streams and transmits a combined optimized stream over TDM and/or Ethernet. On the other end of the backhaul segment at the RNC/BSC site, a second I-Gate 4000 SBO MB receives the optimized stream, restores the original streams (2G, 3G, IP, or PCM), and provides them to the RNC, BSC, or other networks as appropriate.

Additional functionality provided by the I-Gate 4000 SBO MB includes:

- Abis optimization for 2G networks
- ATM and IP-based optimization for 3G networks
- Auto detection of Abis and ATM-based streams
- Pseudo-wire capability (TDM services over IP, SAToP, CESoPSN)
- Timing over packets (TOPSync, IEEE1588v2, SyncE)

TOPSync is extremely important for timing/clock synchronization between the BTS/Node B and the BTS/RNC when they are connected over a packet segment because the cell tower and the BSC/RNC need to be in close synchronization for correct inter-cell handoffs that eliminate dropped calls.

Along with optimizing mobile streams, the I-Gate 4000 SBO MB can optimize PCM streams from TDM networks and native IP streams (from an IP-PBX, for example). Figure 2 includes these streams in its configuration example.

Additional Benefits

The I-Gate 4000 SBO MB has several additional benefits.

- **Wide range of deployment architectures** — Supports numerous network topologies, including Point-to-Point (PTP), Point-to-Multi-Point (PTMP), ring, drop-and-continue, and many others
- **Data-offload configuration** — Can use overlay to separate the 2G voice/data and 3G voice/signaling from the HSPA data offload path
- **Carrier-grade reliability in a small footprint** — Provides carrier-grade reliability in a 1 RU chassis, unparalleled in the industry, for significant CAPEX savings
- **Leading transmission standards** — Supports a variety of transmission technologies, including TDM, IP, and Ethernet. Support for MPLS is planned.

Forecasting Mobile Backhaul Optimization Benefits

The I-Gate 4000 SBO MB can provide a very cost-effective option for increasing capacity on a mobile network by optimizing the backhaul segment. In field trials, the I-Gate 4000 SBO MB has been shown to double a mobile service provider's backhaul capacity and deliver a very attractive return on investment. Backhaul optimization with the I-Gate 4000 SBO MB enables mobile service providers to quickly and cost-effectively augment the capacity in their networks while maintaining a high QoE for end users, which encourages customer retention, attracts new customers, and delivers the additional bandwidth to service a growing number of subscribers.

Because actual increased bandwidth capacity, cost of ownership, and CAPEX/OPEX savings vary widely (depending, for example, on a mobile operator's network size, mix of traffic, cost of leased lines, and location), a detailed analysis is required to accurately forecast specific benefits. Call your local Dialogic sales representative for a free assessment of your particular situation and a detailed analysis that can help you quantify the benefits accurately. Dialogic can also help you design your solution. For local contact information in your region, go to www.dialogic.com/contact.

Acronyms

1xRTT	1x (Single Carrier) Radio Transmission Technology
2G	Second Generation
3G	Third Generation
ARPU	Average Revenue Per User
ATM	Asynchronous Transfer Mode
BTS	Base Transceiver Station
BSC	Base Station Controller
CAPEX	Capital Expenditure
CESoPSN	Circuit Emulation Service over Packet Switched Network
CDMA	Code Division Multiple Access
GPRS	General Packet Radio Service
HSPA	High Speed Packet Access
IP	Internet Protocol
KPI	Key Performance Indicators
LTE	Long Term Evolution
MPLS	MultiProtocol Label Switching
MuX	Multiplexer
OPEX	Operational Expenditure
QoE	Quality of Experience
QoS	Quality of Service
PBX	Private Branch eXchange
PCM	Pulse Code Modulation
PSTN	Public Switched Telephone Network
PTP	Point-To-Point
PTMP	Point-To-Multi-Point
RNC	Radio Network Controller
RU	Rack Unit
SAToP	Structure-Agnostic TDM over Packet
SLA	Service Level Agreement
SMS	Short Message Service
STM-1	Synchronous Transport Module Level One
TDM	Time Division Multiplexing
TOP	Timing Over Packets



www.dialogic.com

Dialogic Inc.
926 Rock Avenue
San Jose, California 95131
USA

INFORMATION IN THIS DOCUMENT IS PROVIDED IN CONNECTION WITH PRODUCTS OF DIALOGIC INC. AND ITS AFFILIATES OR SUBSIDIARIES ("DIALOGIC"). NO LICENSE, EXPRESS OR IMPLIED, BY ESTOPPEL OR OTHERWISE, TO ANY INTELLECTUAL PROPERTY RIGHTS IS GRANTED BY THIS DOCUMENT. EXCEPT AS PROVIDED IN A SIGNED AGREEMENT BETWEEN YOU AND DIALOGIC, DIALOGIC ASSUMES NO LIABILITY WHATSOEVER, AND DIALOGIC DISCLAIMS ANY EXPRESS OR IMPLIED WARRANTY, RELATING TO SALE AND/OR USE OF DIALOGIC PRODUCTS INCLUDING LIABILITY OR WARRANTIES RELATING TO FITNESS FOR A PARTICULAR PURPOSE, MERCHANTABILITY, OR INFRINGEMENT OF ANY INTELLECTUAL PROPERTY RIGHT OF A THIRD PARTY.

Dialogic® products are not intended for use in medical, life saving, life sustaining, critical control or safety systems, or in nuclear facility applications.

Dialogic may make changes to specifications, product descriptions, and plans at any time, without notice.

Dialogic is a registered trademark of Dialogic Inc. and its affiliates or subsidiaries. Dialogic's trademarks may be used publicly only with permission from Dialogic. Such permission may only be granted by Dialogic's legal department at 926 Rock Avenue, San Jose, California 95131 USA. Any authorized use of Dialogic's trademarks will be subject to full respect of the trademark guidelines published by Dialogic from time to time and any use of Dialogic's trademarks requires proper acknowledgement.

The names of actual companies and products mentioned herein are the trademarks of their respective owners. Dialogic encourages all users of its products to procure all necessary intellectual property licenses required to implement their concepts or applications, which licenses may vary from country to country.

Any use case(s) shown and/or described herein represent one or more examples of the various ways, scenarios or environments in which Dialogic® products can be used. Such use case(s) are non-limiting and do not represent recommendations of Dialogic as to whether or how to use Dialogic products.