

GSMATM

LinkedIn Live

TS.43 Entitlement Server Implementation: Real-World Challenges and Proven Solutions

Wednesday, 2 July | 2pm (BST)



GSMA Working Groups



Scan to learn more about
GSMA Working groups

Scan the QR code or email workinggroups@gsma.com for more information

GSMA™

Five reasons you should join GSMA Membership

Discover how we can
transform your business



Agenda

Today's LinkedIn Live session will cover:

TS.43 use cases: Satellite Mode & eSIM Transfer

- Savitha Venkata Rao and Teresa Treiber, T-Mobile

TS.43 Use Cases: On-Device Service Activation for Companion eSIM Device & RCS

- Ashok M. Passavula, Ericsson AB

Q&A

Please share your question on the chat

Previous session can be found:

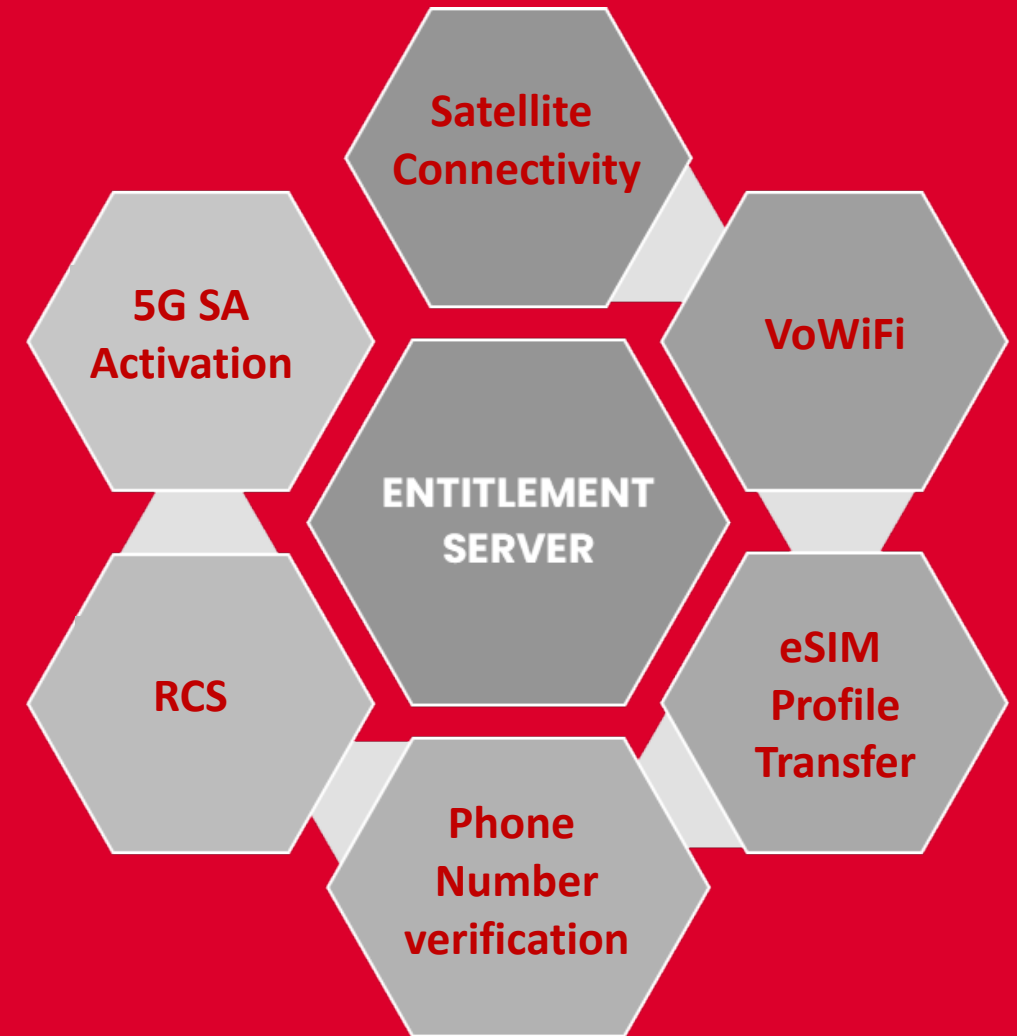



Savitha Venkata Rao

Principal Engineer
T-Mobile



Teresa Treiber

Principal Engineer
T-Mobile



Ashok M. Passavula

Strategic Product Manager
Ericsson AB

TS.43 Use Cases: Satellite Mode & eSIM Transfer



Savitha Venkata Rao

Principal Engineer
T-Mobile



Teresa Treiber

Principal Engineer
T-Mobile



TS.43 Use Cases

T-Mobile & TS.43

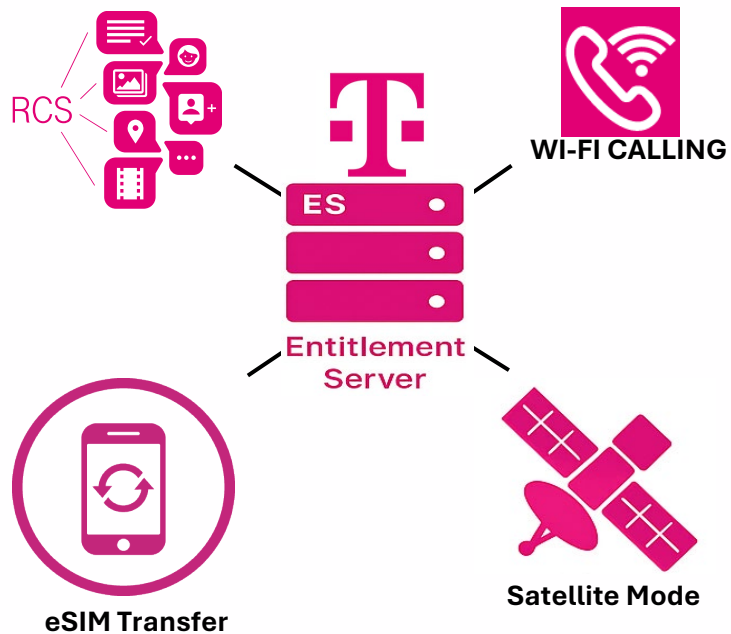

Leveraging Standards to Improve Customer Experience

T-Mobile utilizes the **TS.43 standard** to enable and streamline essential services:

- **RCS (Rich Communication Services)**
- **Wi-Fi Calling**
- **Companion eSIM activation**
- **Satellite Mode**
- **eSIM Transfer**

T-Mobile's TS.43 Journey

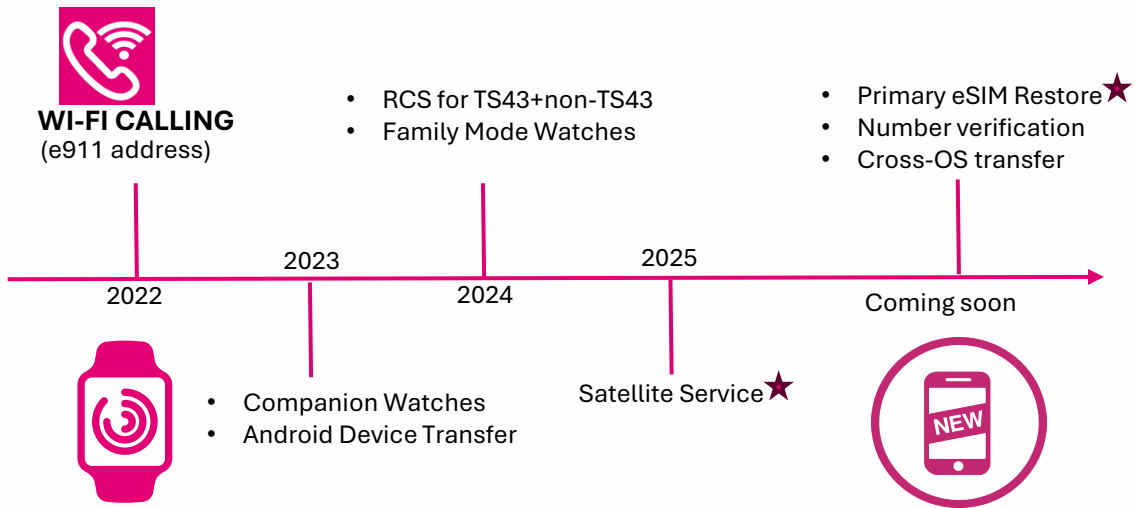

★ Use Cases submitted by T-Mobile and approved in v12.

Services are delivered through **standardized call flows** that:

- **Accelerate time to market**
- **Ensure consistency across all OEMs**
- **Enhance customer experience across platforms**

Satellite Mode
Savitha Venkata Rao

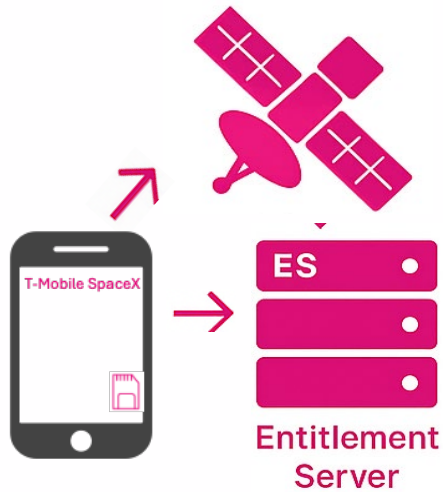

SatMode Entitlement

Unlocking the Future of Satellite Connectivity

- T-Mobile's T-Satellite service is **revolutionizing** how devices access satellite networks.
- Expands device reach **beyond** terrestrial coverage zones.

Empowering Connectivity without Limits

- **Blocks non-optimized devices** → Reduces network load.
- **Standardized, device agnostic flows** → Faster implementation.
- **Webview onboarding** → Easier on-device service activation.

Behind the Magic

- TS.43 v12 introduces standardized entitlement for Satellite connectivity.
- Aligns entitlement logic across OEMs and carriers.
- From backend systems to on-device configurations, SatMode Entitlement handles the complexity so users don't have to.
- Smart status checks: The network knows whether you're satellite-eligible—no manual setup.
- Devices automatically receive the right configuration.

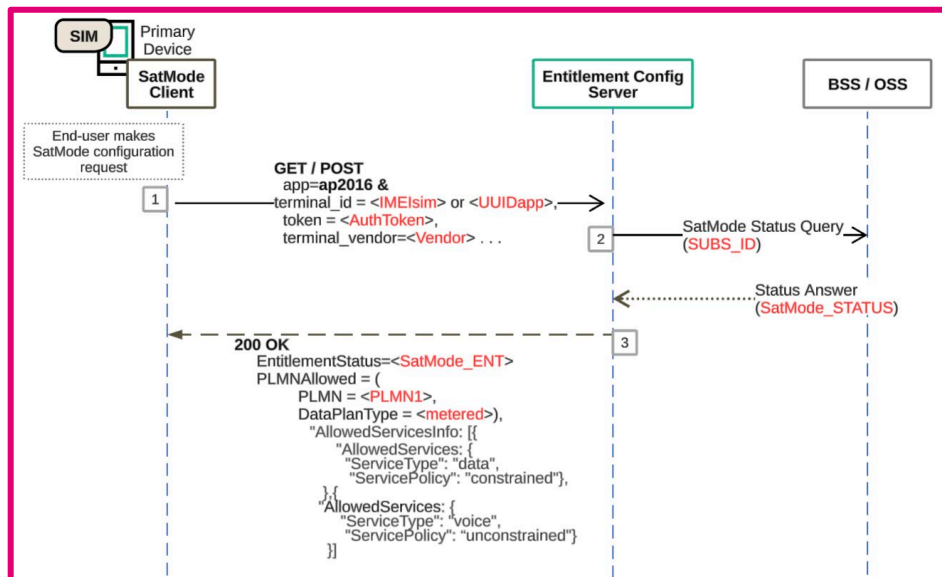

Info specific to T-Satellite can be found here: <https://www.t-mobile.com/coverage/satellite-phone-service>

To get involved and learn how to optimize your app for T-Satellite, app developers can reach out to SatelliteApps@T-Mobile.com

Primary eSIM Transfer

Teresa Treiber

Primary eSIM Transfer

Revolutionizing Device Switching with eSIM Transfer

- Seamless user experience with a simple one step process for transitioning from eSIM or pSIM to eSIM.
- Entitlements performs EAP-AKA authentication and temporary token generation with old active device (source).
- New device (target) performs the transfer request using the temporary token shared from the source.
- Entitlements facilitates the enablement/activation of eSIM on the new device (target).

The Need for TS.43 eSIM Transfers

- Removes the need for QR codes or manual data input.
- Facilitates customer self-service as the industry shifts toward eSIM-only devices.

Real World Use

- TS.43 version 8 introduced standardized entitlement call flows for Primary eSIM Transfer. Version 9 enhanced the security with temporary tokens and general error text for customization of error messages.

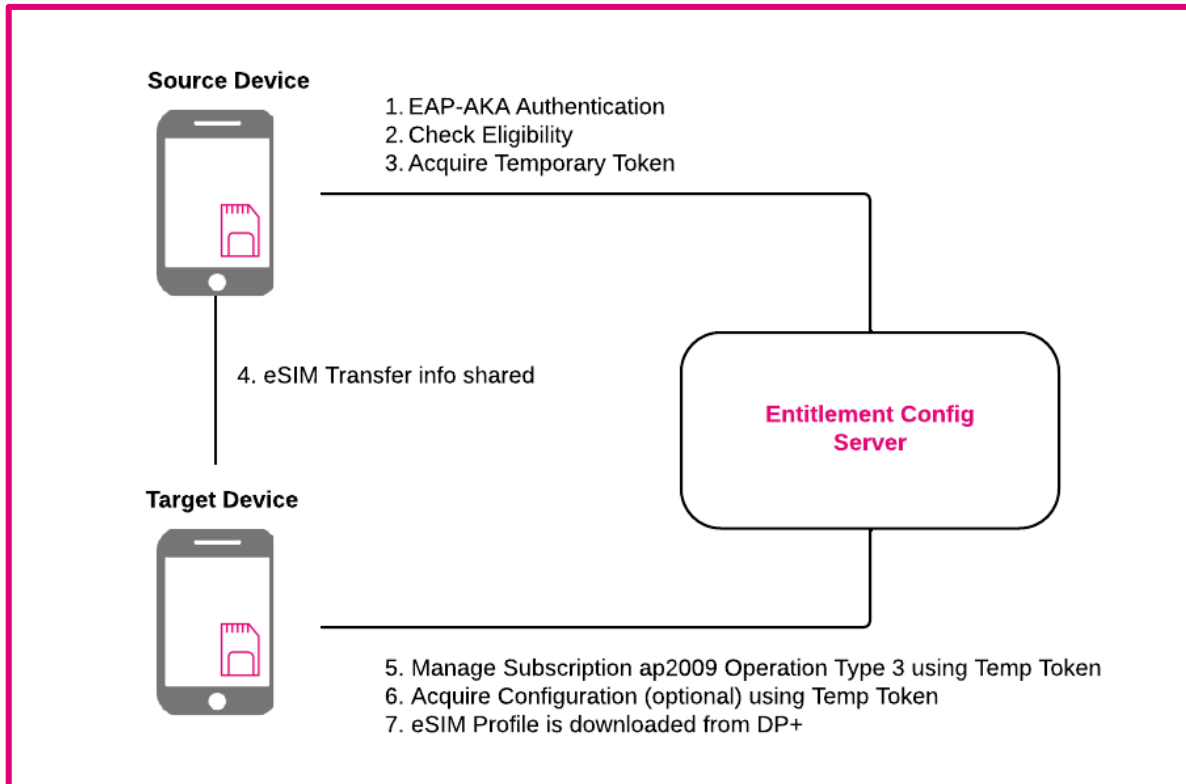

Advantages & Challenges

Advantages

- **Faster Carrier Integration**
Standardized call flows significantly reduce complexity and time-to-market for carrier-side deployments.
- **Seamless Multi-OEM Experience**
Ensures consistent customer experience and quality across diverse OEM ecosystems.
- **Collaborative API Development**
Empowers both carriers and OEMs to co-develop API definitions within the TS.43 framework.

Challenges & Improvements

- **Specification Evolution and Backward Compatibility:** Enhancement of the specification must ensure backward compatibility.
- **Improving Guidance:** Provide clearer guidance on client-side handling of entitlement responses and associated error conditions
- **Process Improvement:** Improve spec standardization timelines to accelerate deployment cycles
- **Success Stories:** The capability to swiftly adapt devices and entitlements alongside continuous improvements.

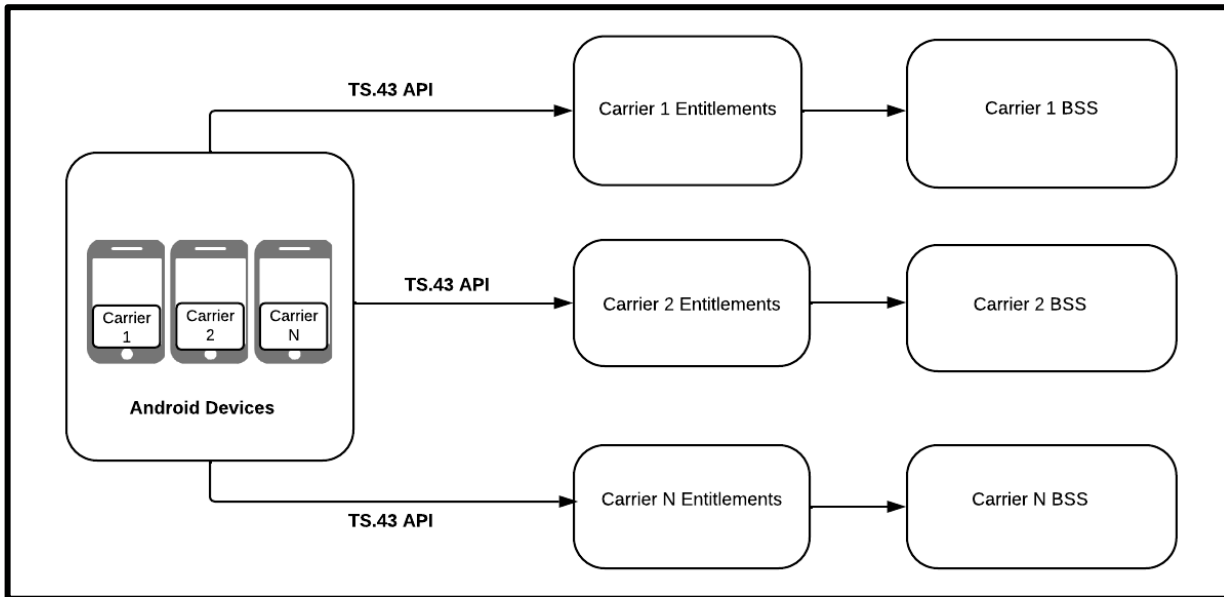

thank you

TS.43 Use Cases: On-Device Service Activation for Companion eSIM Device & RCS



Ashok M. Passavula

**Strategic Product
Manager
Ericsson AB**

The Ericsson Presentation

GSMA TS.43 Webinar

July 2025

Ashok M.Passavula

Strategic Product Manager
Business Area Cloud Software & Services : : Core Networks
Ericsson AB, Stockholm, Sweden

Copyright

© Ericsson AB 2025-30. All rights reserved.

Trademarks

All trademarks are properties of their respective owners.

Agenda

- GSMA TS.43 ODSA for Companion eSIM device Solution : Feature appID : ap2006
 - Solution Brief : Key Takeaways
 - API Evolution of this solution
 - Challenges & Lessons learned
- GSMA TS.43 RCS Solution
 - Solution Overview
 - Challenges & Lessons learned
- Session Key Takeaways
 - How to get started with TS.43
 - Recommendations :TS.43 Solutions Deployments



On-Device Service Activation (ODSA) Solution for Companion eSIM Devices GSMA TS.43

- Solution Brief : Key Takeaways
- API Evolution of this Solution
- Challenges & Lessons learned

Solution Brief : Key Takeaways

GSMA TS.43 ODSA for Companion eSIM Devices – Feature appID: ap2006

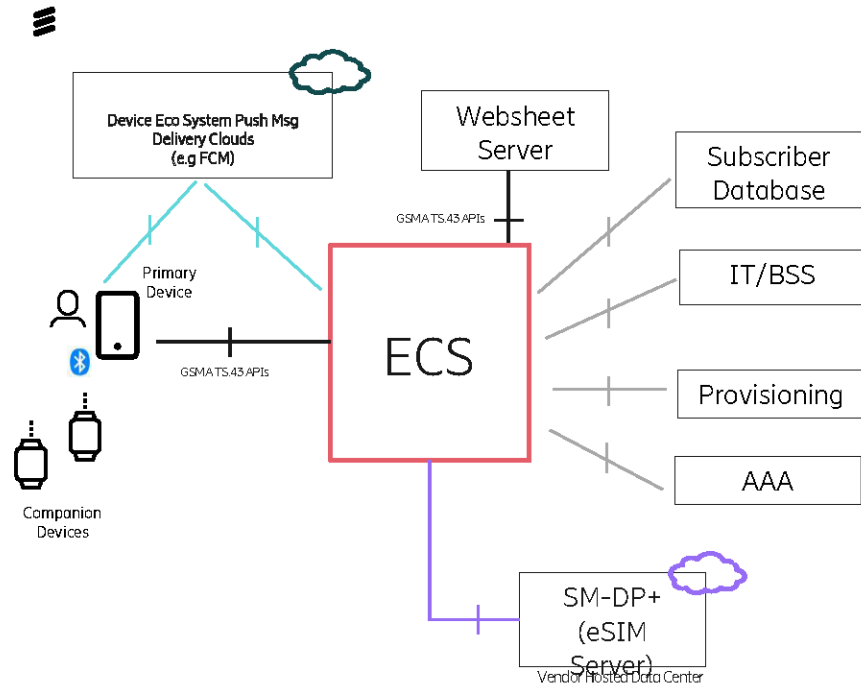

GSMA TS.43 defined node ECS: Entitlement Configuration Server
 GSMA TS.43 abbreviation ODSA: On-Device Service Activation

— GSM TS.43 defined interfaces
 — GSM SGP defined interfaces

— Device OEM/OS vendor defined interfaces
 — Carrier and/or ECS vendor defined/selected interfaces

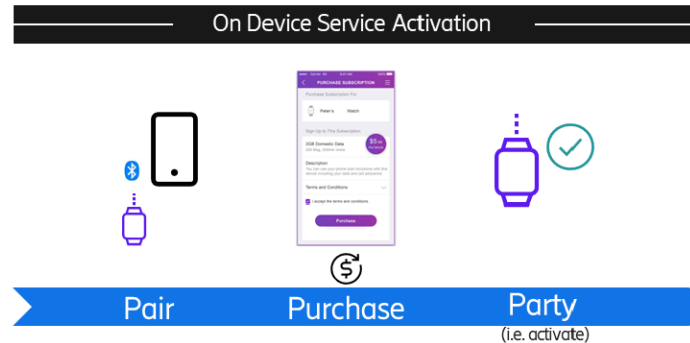

- Solution implementation approach differs from carrier to carrier, there are several different ways to realize the solution.
- Several integration points involved.
- Touch points directly or indirectly through out the network crossing several domains e.g. IMS, Core Network, BSS,OSS etc.,

Popular Use Cases within this solution

*** Immediate/delay download ICCID profile

01 Subscriber activates a companion device(shared number)*** via Websheet Server.



02 Subscriber transfers the existing subscription from one companion device to another via native GUI *** (one click)

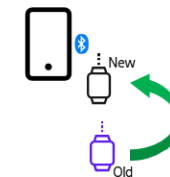

GSMA TS.43 : ODSA Companion eSIM device solution/API evolution

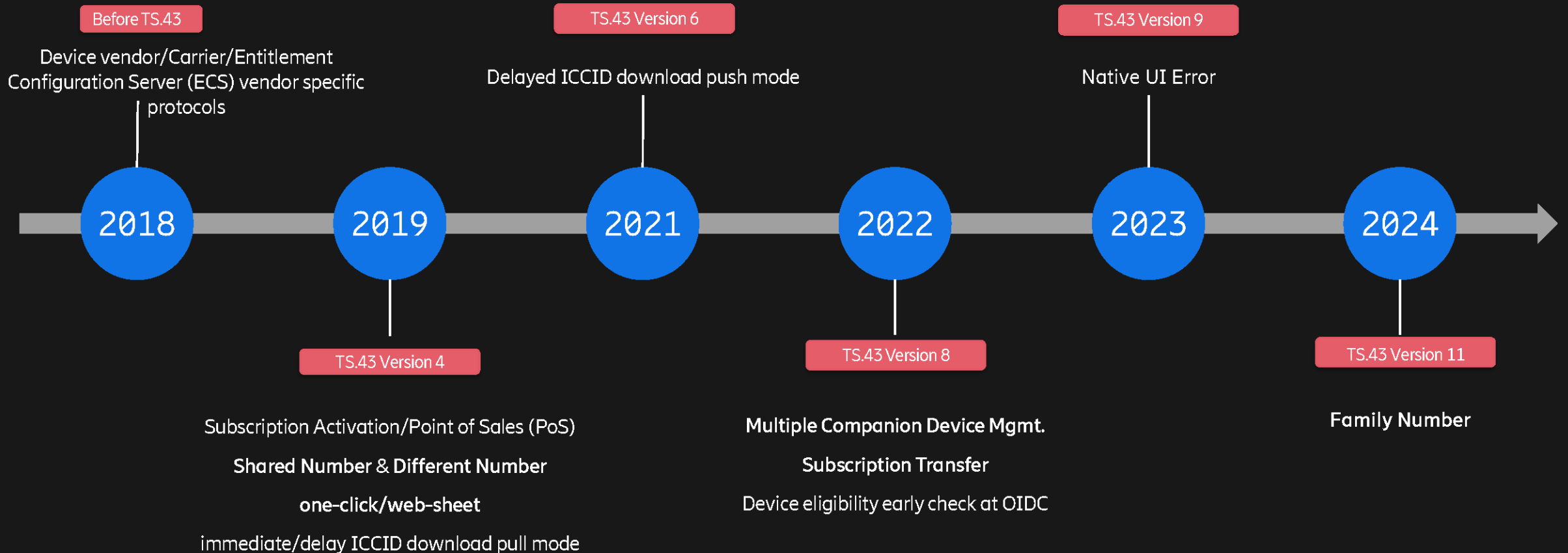

GSMA TS.43 spec continues to evolve with more use cases based on market demand and the continuous need for innovation

TS.43 ODSA for companion eSIM devices Solution Challenges & Lessons Learned



01

- **Challenge:** When TS.43 introduced (2018-2019) the ap2006 the first time, the industry faced the problem of migrating from the proprietary API (not TS.43 compliant) to TS.43 standard gradually.
 - ✔ **Lessons Learned:** ECS had to support dual or multiple stacks/specifications and seamlessly migrates the association between companion and primary devices to ensure a smooth transition.
-

02

- **Challenge:** As more device vendors adopt the TS.43 specification, variations have emerged in how the spec is interpreted and implemented—for example, differences in handling Device API parameters such as whether they are mandatory or optional, or in parameter lengths etc.,
 - ✔ **Lessons Learned:** ECS had to offers flexible configuration capabilities to accommodate vendor- or client-specific implementations and support variations across different clients accordingly.
-

03

- **Challenge:** In use cases such as companion smartwatch activation and transfer, each carrier handles the process differently, with varying workflows and backend integrations.
 - ✔ **Lessons Learned:** ECS had to provide flexible backend integrations and innovation to adapt to different carrier's network environment, there's no silver bullet to build a unique solution adapt to all carriers.
-



RCS Solution : Cross OS RCS Service Enablement GSMA TS.43

- Solution Overview
- Challenges & Lessons learned

Solution Overview

GSMA TS.43 RCS Solution— Cross OS RCS Enablement



Enabling Rich Communication Services (RCS) between two different mobile device OS ecosystems.

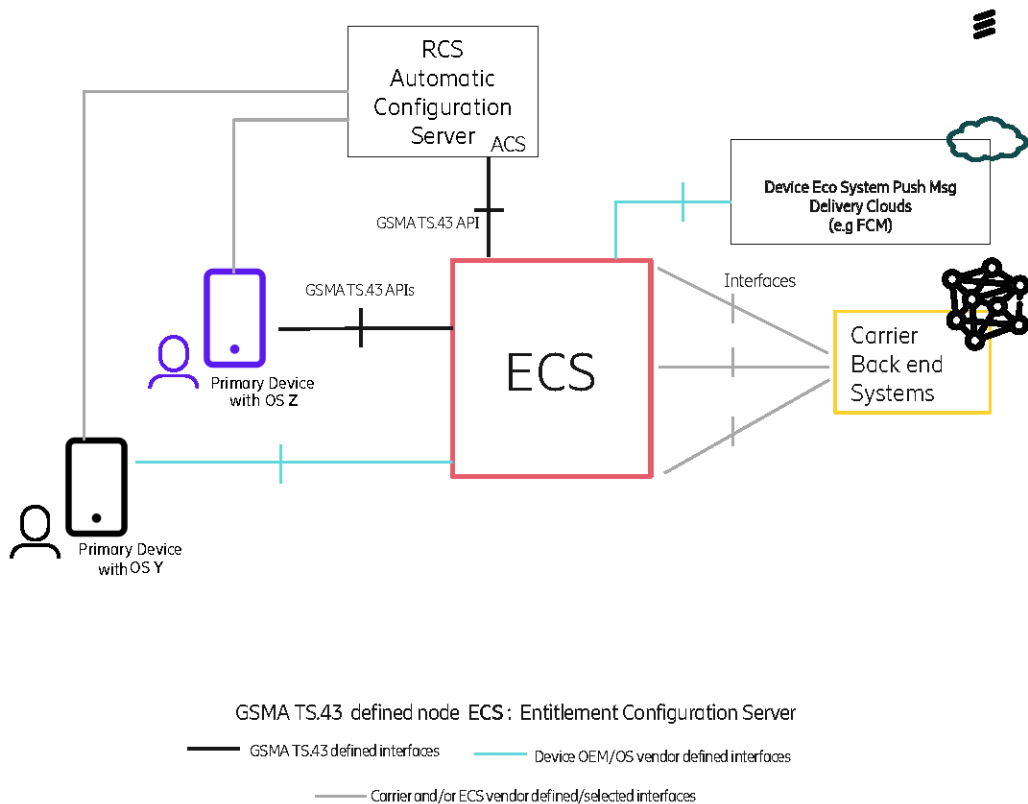

In doing so, TS.43 enhances authentication, service eligibility control & user privacy protection

- Authentication

TS.43 enhances the way the RCS client authenticates itself against ACS to obtain the RCS profile, transitioning from OTP to a more secure and seamless SIM-AUTH-based “Temporary token” (ap 2014).

- Service Eligibility

TS.43 gives carriers the possibility to enforce per-subscriber eligibility control for the RCS service, compared to the static configuration for all subscribers.

- User Privacy

Instead of a plain text IMSI as the unique identifier of the subscriber at the ACS, a new anonymized SIM ID provides better end-user privacy protection.

GSMA TS.43 Rich Communication Service (RCS) CrossOS Enablement Challenges & Lessons Learned



01

- Challenge: The error codes between the ECS and the Automatic Configuration Server (ACS) are not sufficiently granular to distinguish between different error scenarios.

Lessons Learned:

- ✔ ECS had to utilize the vendor's own proprietary field in the response body to specific different errors.
- ✔ We recommend a new CR to TS.43 to detail the errors.

02

- Challenge: The complete lifecycle of the anonymous SIM ID is not covered by TS 43. For example, TS.43 does not include the RCS deactivation use case.

Lessons Learned:

- ✔ ECS had to utilize the vendor's proprietary method to propagate the SIM ID mapping to the Carrier's backend system.
- ✔ We recommend a new CRs to TS.43 to add the RCS service deactivation flow to allow the ECS to talk to the RCS application server (ACS) directly.



Session Key Takeaways

How to get started with TS.43 ?

Recommendations for TS.43
Solutions Deployments



Key Takeaways (Part 1 of 2)

How to get started with TS.43?



GSMA TS.43 is a technical specification that defines the procedure for configuration of a device-based service performed during the entitlement verification of the service or during the activation/enablement, provisioning & orchestration of that service.

01 TS.43 Specification



Review the Official TS.43 documentation available at the GSMA Site
https://www.gsma.com/newsroom/gsma_resources/ts-43-service-entitlement-configuration/

02 Key Concepts



Get familiar with the TS.43 Concepts: entitlement client, entitlement server, Application server, Push server, eSIM Server etc..
...., as this will help you to understand the roles and the end-to-end flows

03 Use Cases



Carriers should identify the Use Cases that should be implemented as a priority as TS.43 covers multiple scenarios and describes different flows.

E.g eSIM Activation and transfer, RCS, and Satellite Mode.

04 Implementation



Implement the Carrier Entitlement Server components.
Define the selected security aspects (EAP-AKA authentication, token, etc.).
Get support from device vendors (client) and entitlement configuration server vendors, when applicable.

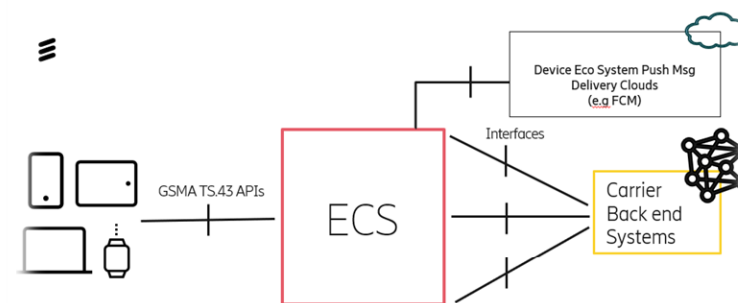

Key Takeaways (Part 2 of 2) For GSMA TS.43 Solutions Deployments



Prioritize

Prioritize the entitlement services & use cases



Identify

Identify the impacted domains & networks



Design

Design for current and future needs



Secure

Security & Privacy reqs
+ Know Traffic Patterns

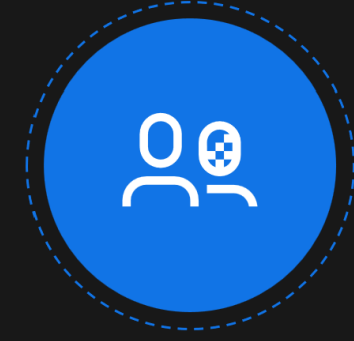

Contribute

Contribute to GSMA TS.43



ERICSSON

GSMA™

Q&A

Survey



Scan to participate

Please take a moment to complete this short survey

- It will take just 2 mins
- GSMA Confidential (Disclaimer Note: All responses will be anonymous)
- Thank you!