

GSMA

VoLTE Implementation Guide

September 2025

Navigation

Introduction

>

Business Drivers

This section contains information that the MNO can use in its business plan to justify launching VoLTE roaming outbound and/or inbound.

>

Selecting Roaming Partners

A summary of some key issues related to handsets and frequencies that will affect the selection of roaming partners and steering of roaming.

>

Billing Issues

>

Technical Issues for S8HR VoLTE Roaming

>

VoLTE Roaming Checklist

>

VoLTE/IMS Issues Impacted by S8HR VoLTE Roaming

Recommendations/solutions to VoLTE/IMS related issues that are impacted by S8HR VoLTE roaming.

>

SMSoIP

Further details on SMSoIP covering; Service Enablement; Billing; and Message Flows.

>

IMS Emergency Call for S8HR Inbound Roamers

>

Regulatory Aspects of S8HR VoLTE Roaming

Regulatory aspects that are impacted by S8HR VoLTE roaming.

>

VoLTE/Roaming Testing

Describes the ecosystem, methodology, profiles and test cases for VoLTE/Roaming testing.

>

IR.21 Information related to VoLTE Roaming

>

VoLTE Implementation Guide

1	Introduction	5
1.1	Overview	5
1.2	Scope	5
1.3	References	6
1.4	Acknowledgements	6
2	Business Drivers	7
2.1	Business drivers of VoLTE on Home Network	7
2.2	Business Drivers for VoLTE Roaming	8
2.2.1	Customer Experience	8
2.2.2	Coverage	8
2.3	Possible Business Case Justifications (quick bullet points)	8
3	Selecting Roaming Partners - Handsets, Coverage, and Capacity Bands	10
3.1	Frequencies	10
3.2	Handsets	11
3.3	Device based Steering of Roaming	12
4	Billing Issues	13
4.1	Comparison of QCI-based charging and APN-based charging	13
4.2	Signalling	13
4.3	Retail Presentation	15
4.3.1	Billing from Home Network Elements	15
4.3.2	Time Zones	15
5	Technical Issues for S8HR VoLTE Roaming	16
5.1	VoLTE/IMS Issues	16
5.2	SMS Service	16
5.3	Emergency Calling	16
5.4	Regulatory Aspects	18
5.5	Testing Considerations	18
5.6	IR.21 Impacts	19
5.7	Fraud Systems	19
Annex A	VoLTE Roaming Checklist	20
Annex B	VoLTE/IMS Issues Impacted by S8HR VoLTE Roaming	24
B.1	Enable/Disable IMS APN	24
B.2	IMS Registration and SIP Sessions	24
B.3	QoS Considerations	24
B.4	Determination of Location / Time-Zone (TZ)	25
B.5	IPv4/IPv6 Compatibility Issues	25
B.6	Local Number Translation & Routing	26
B.7	SRVCC Handling	26
B.8	Regulatory Impacts on IMS	26
B.9	Summary of MME and HSS Requirements	26
Annex C	SMSoIP	28

C.1	Service Enablement	28
C.2	Billing	28
C.3	Message Flows	29
Annex D	IMS Emergency Call for S8HR Inbound Roamers	31
D.1	PS Domain Selection	31
D.2	IMS EC Procedures	31
D.3	Non-UE Detected Emergency Calls	31
D.4	Managing VPMN Specific Emergency Codes	32
D.5	SIM-less Emergency Calling	Error! Bookmark not defined.
D.6	eCall	33
Annex E	Regulatory Aspects of S8HR VoLTE Roaming	35
E.1	Lawful Interception	35
E.1.1	Definition	35
E.1.2	National Regulation	35
E.1.3	Solutions	36
E.1.4	Future proof and consideration for 5G	38
E.2	Retained Data	38
E.2.1	Definition	38
E.2.2	National Regulation/Solutions	38
E.3	Priority Services (MPS/WPS)	38
E.3.2	Multimedia Priority Services (MPS)	39
E.4	Lawful Intercept Scenarios	39
Annex F	VoLTE/Roaming Testing	44
F.1	Testing Ecosystem & Methodology	44
F.2	Network Testing	44
F.3	Device Testing	46
F.4	Test Cases	47
F.5	Sharing of Test Results	47
F.6	Testing Summary	47
Annex G	IR.21 Information related to VoLTE Roaming	49
G.1	VoLTE Roaming Information	49
G.2	LTE Roaming Information (part1)	50
G.3	LTE Roaming Information (part2)	50
G.4	LPWA Roaming Information	51

1 Introduction

1.1 Overview

LTE (Long Term Evolution), with its capability and optimized architecture to provide mobile broadband services, has been adopted aggressively by operators over the world and it is now provided by over 754¹ operators around the world. As LTE is an All-IP network, the voice and messaging services provided over CS (Circuit-Switched) domain in previous generations needed to be adapted and evolved to work over an LTE network.

VoLTE (Voice over LTE) addresses the migration to a PS (Packet Switched) only domain by leveraging on the capabilities of the IMS (IP Multimedia Subsystem) to offer voice and messaging services over LTE. In this context, VoLTE is important because it enables decommissioning of legacy CS networks as voice services can be migrated to LTE networks. Furthermore, VoLTE provides customers with enhanced voice quality, reduced time taken to establish call and the possibility of placing video calls.

An important further consideration is the support of VoLTE for roaming UEs. Such capability needs to be widespread before legacy CS networks can be decommissioned. There are two competing technologies for the provision of VoLTE Roaming, namely LBO (Local Break-Out) and S8HR (S8 Home Routing). Current deployments of VoLTE Roaming are all based on S8HR. All future deployments of VoLTE Roaming are recommended to be, and indeed expected to be, based on S8HR. The LBO option has thus been removed from a number of GSMA PRDs.

1.2 Scope

This document provides details of commercial S8HR VoLTE roaming deployments which roaming managers may find of use as they plan and execute their first S8HR VoLTE roaming project.

Information provided includes business plan considerations, fraud system impacts, considerations on roaming support (handsets and frequencies), billing considerations, regulatory considerations and it includes a sample checklist/ questionnaire that can be used by both the HPMN and the VPMN to assess if the other MNOs network will support their roamers and to assist in configuration requirements.

Additionally, technical issues and solutions are addressed and explained in more detail in annexes of this document.

LBO Roaming is out of scope for this document.

Note:

- BA.65[7] LTE Roaming Implementation Handbook covers issues related to implementing LTE, a network architecture for wireless access based on an all IP network.

¹ GSMA.com as of January 13, 2020

- BA.50[6] Agreements Handbook has information on adding VoLTE Roaming to the International Roaming Agreement.

1.3 References

Ref	Doc Number	Title
[1]	3GPP TS 23.167	IP Multimedia Subsystem (IMS) emergency sessions
[2]	IETF RFC 8147	Next-Generation Pan-European eCall
[3]	3GPP TS 34.229	User Equipment (UE) conformance specification
[4]	3GPP TS 36.101	Evolved Universal Terrestrial Radio Access (E-UTRA); User Equipment (UE) radio transmission and reception
[5]	GSMA PRD AA.13	STIRA Common Annexes
[6]	GSMA PRD BA.50	Agreements Handbook
[7]	GSMA PRD BA.65	LTE Roaming Implementation Handbook
[8]	GSMA PRD IR.21	Roaming Database Structure and Updating Procedures
[9]	GSMA PRD IR.25	VoLTE Roaming Tests
[10]	GSMA PRD IR.34	Guidelines for IPX Provider Networks
[11]	GSMA PRD IR.65	IMS Roaming, Interconnection and Interworking Guidelines
[12]	GSMA PRD IR.88	LTE and EPC Roaming Guidelines
[13]	GSMA PRD NG.119	Emergency Communications
[14]	GSMA PRD TD.50	TAP Test Cases for VoLTE Roaming Testing
[15]	GSMA PRD TD.58	TAP3.12 Implementation Handbook
[16]	GSMA PRD TD.201	Common Billing and Charging Processes
[17]	GSMA PRD TD.202	Billing and Charging Evolution Reports
[18]	GSMA PRD TS.11	Device Field & Lab Tests
[19]	GSMA PRD TS.32	Technical Adaptation of Device through late customisation
[20]	3GPP TS 24.229	IP multimedia call control protocol based on Session Initiation Protocol (SIP) and Session Description Protocol (SDP); Stage 3
[21]	3GPP TS 22.153	Multimedia Priority Service
[22]	3GPP TS 33.127	Lawful Interception (LI) architecture and functions
[23]	3GPP TS 22.101	Service aspects; Service principles
[24]	GSMA PRD IR.92	IMS Profile for Voice and SMS
[25]	3GPP TS 33.107	3G Security; Lawful Intercept Architecture and Functions
[26]	3GPP TS 23.122	Non-Access-Stratum (NAS) functions related to Mobile Station (MS) in idle mode

1.4 Acknowledgements

The content of this document reflects both feedback from MNOs who have already launched S8HR VoLTE Roaming and encountered/solved various issues as well as input from the GSMA NG GERI WG which completed a study of S8HR VoLTE topics in six streams covering VoLTE Issues, Emergency Call handling, SMS, Regulatory Issues, Testing and IR.21 impacts respectively.

Both sources have contributed significantly to this document and are hereby acknowledged.

[Next Section \(Business Drivers\) >](#)

2 Business Drivers

This section contains information that the MNO can use in its business plan to justify launching VoLTE roaming outbound and/or inbound.

2.1 Business drivers of VoLTE on Home Network

VoLTE provides five benefits over traditional CS voice calls.

Migration to IP. VoLTE enables operators to migrate their circuit switched infrastructure (e.g. 3G) to a fully IP centric network. Without VoLTE, 4G networks cannot support voice service, therefore operators wishing to offer this communication capability will need to still support legacy technologies and use CSFB (CS Fallback) techniques to redirect the user towards them when a call is made or received.

Voice Quality. VoLTE offers higher voice quality than legacy circuit switched voice. As shown in Figure 1, VoLTE provides voice in wider range of frequency and enhances the voice quality significantly. With implementation of EVS (Enhanced Voice Services) codec, the range is even extended, and customers can enjoy very high-quality voice.

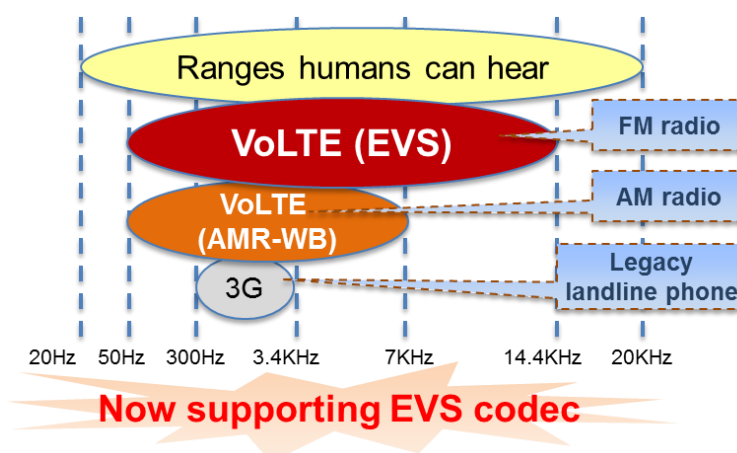

Figure 1: Higher voice quality offered by VoLTE

Fast Call setup. Another prominent advantage of VoLTE is the shorter call setup time compared to legacy circuit switched voice services. Call setup time is the time it takes from initiating the call to hearing from or speaking to the called party, and VoLTE reduces the call setup time to about a third of that of legacy circuit switched voices.

Multimedia communications. VoLTE also enables video calls to be provided in conjunction with HD voice (ViLTE: Video over LTE). This means that not only video calls are possible between VoLTE subscribers, but also switching between Video and Voice is supported.

Efficiency. As VoLTE calls are natively supported by LTE networks, the scarce radio resources are used much more efficiently than with legacy technologies.

2.2 Business Drivers for VoLTE Roaming

2.2.1 Customer Experience

VoLTE roaming extends all the benefits mentioned in 2.1 to subscribers that are roaming abroad resulting in the same user experience as at home. S8HR VoLTE roaming also unlocks two additional key benefits to subscribers:

- Firstly, S8HR enables exactly the same user experience as when non-roaming
- Secondly, voicemail is more reliable as there is no need to interwork with VPMN (Visited Public Mobile Network) and call forwarding is activated as it would be when the subscriber is at home.

2.2.2 Coverage

Launching VoLTE roaming provides better coverage in two ways:

- New Operators - There are a number of new operators that launched with 4G only. Launching VoLTE roaming provides access to those networks for inbound roamers.
- Existing Partners Closing 2G and/or 3G coverage - Operators are decommissioning 2G, 3G or both to re-farm the spectrum for 4G and 5G. Some operators maintain older networks but with minimal spectrum to support IoT devices. Even if other operators maintain legacy networks, coverage is never identical leading to coverage gaps and network congestion on the remaining networks.

2.3 Possible Business Case Justifications (quick bullet points)

- Operational efficiencies
 - Fewer network elements involved for S8 Home Routed VoLTE traffic
 - Simplified roaming agreements for VoLTE
 - Reduced development and implementation effort
 - Reduced testing effort
 - Bill shock mechanisms not impacted
 - Fewer billing touch points
 - Fewer IPX services associated with roaming
- Implementation Advantages of S8HR VoLTE Roaming
 - The reduction in complexity of development, deployment, and settlement represents a faster “time to market” solution
 - Roaming architecture model is similar to existing roaming for legacy network and LTE data networks
 - Accelerate implementation of VoLTE Roaming worldwide
- Strategy/Competition

- Strategic objective to remain preferred roaming destination of choice for inbound roamers in relation to other competitors.
- Competitive Pressures in-home market
- Global circuit switched footprint is now in decline
- With the number of operators that need to launch VoLTE roaming, a late transition will mean waiting in testing queues to enable launch
- Revenues and Expenses
 - Enables opportunity to expand into new roaming partner relations (e.g., new “greenfield” LTE operators), both international and domestic
 - IoT solutions with voice (such as eCalling in Automobiles) have to plan for 10+ years in the future. VoLTE is being selected by many as the solution to future proof deployments. Lack of VoLTE means those devices can’t access an operator’s network.
 - Lower deployment costs
 - Reduced contractual complexities while expanding contractual opportunities
 - Capitalize on revenue opportunities
 - Reduced operating expenses
 - Lower wholesale costs for Voice via volume-based charging, e.g. Voice as MB.
- Consumer
 - Provide customers with a world-class VoLTE/IMS Roaming solution
 - Provides customers with best global footprint including protecting from being impacted by the shrinking footprint of circuit switched networks.

Next Section (Selecting Roaming Partners) >

3 Selecting Roaming Partners - Handsets, Coverage, and Capacity Bands

Handsets and the bands they support are very important in the launch of VoLTE roaming. Below is a summary of some key issues related to handsets and frequencies that will affect the selection of roaming partners and steering of roaming

3.1 Frequencies

When reviewing a roaming partner for compatibility, it is important to check that the frequency bands supported in the HPMN's VoLTE capable phones are available in the VPMN's network and that the supported bands have sufficient coverage. The voice quality experience with VoLTE highly depends on a match between device Radio Frequency (RF) capabilities and the serving LTE network's RF coverage. Operators prescribe RF bands in devices that they sell to their customers to match the RF bands that they use in their own network.

Low spectrum band is used as the primary coverage band (e.g. 800 MHz, B20). High spectrum band is used for capacity expansion (e.g. 2.7 GHz, B7). High spectrum has less geographical coverage vs. low spectrum. High spectrum also has trouble with in-building penetration, but can be reused more often to add capacity. It may be the case that the VPMN supports a high spectrum band that the VPMN has in its phone but that the VPMN's coverage band is one not supported by the HPMN's phone. As a result, devices that are optimized for use by the HPMN may not have a good user experience when roaming in the VPMN.

Table 1 is a sample of some of the frequency bands in use² :

E-UTRA Operating Band	Uplink (UL) operating band BS receive UE transmit		Downlink (DL) operating band BS transmit UE receive		Duplex Mode
	F _{UL_low}	F _{UL_high}	F _{DL_low}	F _{DL_high}	
1	1920 MHz	1980 MHz	2110 MHz	2170 MHz	FDD
2	1850 MHz	1910 MHz	1930 MHz	1990 MHz	FDD
3	1710 MHz	1785 MHz	1805 MHz	1880 MHz	FDD
4	1710 MHz	1755 MHz	2110 MHz	2155 MHz	FDD
5	824 MHz	849 MHz	869 MHz	894MHz	FDD
6 ¹	830 MHz	840 MHz	875 MHz	885 MHz	FDD
7	2500 MHz	2570 MHz	2620 MHz	2690 MHz	FDD
8	880 MHz	915 MHz	925 MHz	960 MHz	FDD
9	1749.9 MHz	1784.9 MHz	1844.9 MHz	1879.9 MHz	FDD
10	1710 MHz	1770 MHz	2110 MHz	2170 MHz	FDD
11	1427.9 MHz	1447.9 MHz	1475.9 MHz	1495.9 MHz	FDD
12	699 MHz	716 MHz	729 MHz	746 MHz	FDD
13	777 MHz	787 MHz	746 MHz	756 MHz	FDD
14	788 MHz	798 MHz	758 MHz	768 MHz	FDD
17	704 MHz	716 MHz	734 MHz	746 MHz	FDD
18	815 MHz	830 MHz	860 MHz	875 MHz	FDD
19	830 MHz	845 MHz	875 MHz	890 MHz	FDD
20	832 MHz	862 MHz	791 MHz	821 MHz	FDD

² 3GPP TS 36.101[4], Table 5.5-1 E-UTRA operating bands

E-UTRA Operating Band	Uplink (UL) operating band BS receive UE transmit		Downlink (DL) operating band BS transmit UE receive		Duplex Mode
	F_{UL_low}	F_{UL_high}	F_{DL_low}	F_{DL_high}	
21	1447.9 MHz	1462.9 MHz	1495.9 MHz	1510.9 MHz	FDD
22	3410 MHz	3490 MHz	3510 MHz	3590 MHz	FDD
23 ¹	2000 MHz	2020 MHz	2180 MHz	2200 MHz	FDD
24	1626.5 MHz	1660.5 MHz	1525 MHz	1559 MHz	FDD
25	1850 MHz	1915 MHz	1930 MHz	1995 MHz	FDD
26	814 MHz	849 MHz	859 MHz	894 MHz	FDD
27	807 MHz	824 MHz	852 MHz	869 MHz	FDD
28	703 MHz	748 MHz	758 MHz	803 MHz	FDD
30 ¹⁵	2305 MHz	2315 MHz	2350 MHz	2360 MHz	FDD
31	452.5 MHz	457.5 MHz	462.5 MHz	467.5 MHz	FDD
33	1900 MHz	1920 MHz	1900 MHz	1920 MHz	TDD
34	2010 MHz	2025 MHz	2010 MHz	2025 MHz	TDD
35	1850 MHz	1910 MHz	1850 MHz	1910 MHz	TDD
36	1930 MHz	1990 MHz	1930 MHz	1990 MHz	TDD
37	1910 MHz	1930 MHz	1910 MHz	1930 MHz	TDD
38	2570 MHz	2620 MHz	2570 MHz	2620 MHz	TDD
39	1880 MHz	1920 MHz	1880 MHz	1920 MHz	TDD
40	2300 MHz	2400 MHz	2300 MHz	2400 MHz	TDD
41	2496 MHz	2690 MHz	2496 MHz	2690 MHz	TDD
42	3400 MHz	3600 MHz	3400 MHz	3600 MHz	TDD
43	3600 MHz	3800 MHz	3600 MHz	3800 MHz	TDD
44	703 MHz	803 MHz	703 MHz	803 MHz	TDD
45	1447 MHz	1467 MHz	1447 MHz	1467 MHz	TDD
46	5150 MHz	5925 MHz	5150 MHz	5925 MHz	TDD ⁸
47	5855 MHz	5925 MHz	5855 MHz	5925 MHz	TDD11
48	3550 MHz	3700 MHz	3550 MHz	3700 MHz	TDD
49	3550 MHz	3700 MHz	3550 MHz	3700 MHz	TDD16
50	1432 MHz	1517 MHz	1432 MHz	1517 MHz	TDD13
51	1427 MHz	1432 MHz	1427 MHz	1432 MHz	TDD13
65	1920 MHz	2010 MHz	2110 MHz	2200 MHz	FDD
66	1710 MHz	1780 MHz	2110 MHz	2200 MHz	FDD ⁴
68	698 MHz	728 MHz	753 MHz	783 MHz	FDD
70	1695 MHz	1710 MHz	1995 MHz	2020 MHz	FDD ¹⁰
71	663 MHz	698 MHz	617 MHz	652 MHz	FDD
72	451 MHz	456 MHz	461 MHz	466 MHz	FDD
73	450 MHz	455 MHz	460 MHz	465 MHz	FDD
74	1427 MHz	1470 MHz	1475 MHz	1518 MHz	FDD

Table 1: LTE Frequency Bands

3.2 Handsets

Once ready to roam, HPMNs need to ensure that their handsets have VoLTE roaming enabled. Initial setting of VoLTE enabled handsets distributed by most operators were found to not have VoLTE roaming enabled. Operators must work with their handset vendors to modify the defaults. The restriction is typically removed with software updates or OTA configuration settings, which requires collaboration and support from device manufacturers.

To facilitate interoperability, GSMA PRD TS.32 [19] documents a minimum set of configuration parameters to be supported on devices and includes (inter alia) both LTE and IMS settings. Subsequently, the GSMA launched its Network Settings Exchange (NSX) database (see <https://www.gsma.com/services/nsx/>) which enables MNOs to specify their preferred configuration settings and for OEMs to access these settings and thus customize their devices on SIM insertion. In addition, work is ongoing to limit differences between MNOs (e.g. in a country or region) to encourage commonality of settings and reduce the testing overhead in proving devices for all of the required configuration settings.

On attaching to a VPMN, the device is provided with the VOPS (Voice over Packet Switched) Indicator which informs the device whether VoLTE is applicable. This indicator must only be set by the network if a S8HR VoLTE Roaming agreement exists for the inbound roamer.

3.3 Device based Steering of Roaming

Due to the varying array of VPMN frequencies, and bands in use as well as the potential for handset incompatibility as noted in Section 3.1, VoLTE roaming presents an increased risk for incompatibility between HPMN handsets and corresponding VPMN networks. VoLTE roaming introduces an additional set of potential conditions that could impact the ability for HPMN devices to achieve and maintain an optimized roaming experience. Examples of such conditions include:

- device that does not have the software update or configuration required to use VoLTE roaming;
- device is capable of VoLTE roaming but does not have the correct spectrum band to function well with the preferred roaming partner.

As such, HPMNs should consider a device based steering solution to ensure that their devices can efficiently register only on desired compatible networks prior to launching VoLTE roaming.

Next Section (Billing Issues) >

4 Billing Issues

4.1 Comparison of QCI-based charging and APN-based charging

Prior to S8HR VoLTE roaming, LTE data services were provided as best effort. With VoLTE S8HR Roaming, the data bearers are assigned different QCI values and the QCI value affects network resource usage differently and the QoS (Quality of Service) is assigned to a specific bearer. Regardless of whether the operators decide to charge differently for S8HR data bearers, it is recommended that operators be able to identify the traffic to enable billing and reporting.

It is possible to charge based on QCI of the bearer used or on APN used by roamers. MNOs will need to discuss in advance the billing options that their Roaming Partner supports.

The difference between QCI-based charging and APN-based charging is best depicted by Figure 2. While APN-based and QCI-based charging would most likely not make a difference for data roaming, it would be significantly different for S8HR VoLTE Roaming as there are potentially three different QCI values (voice media, video media and IMS signalling) involved. If APN-based charging is employed, all of the three types of bearers would be treated the same in charging (i.e. APN-based charging would consider 100kb of IMS signalling to be same as 100kb of voice media). On the other hand, QCI-based charging would differentiate charging based on QCI and allows operators to apply different rates for different QCIs. However, the effort to differentiate by QCI may not be beneficial when considering the relative data volumes over the IMS-APN between IMS signalling (<15KBytes/call), IMS voice media (0.31Mbytes/minute for AMR-WB using the highest mode-set at 23.85Kbits/second) and IMS video media (conservatively at around 2.9Mbytes/minute for H.264). Of course, the total data volume on the IMS-APN is in turn dwarfed by that on the data/INTERNET APN using QCI=9.

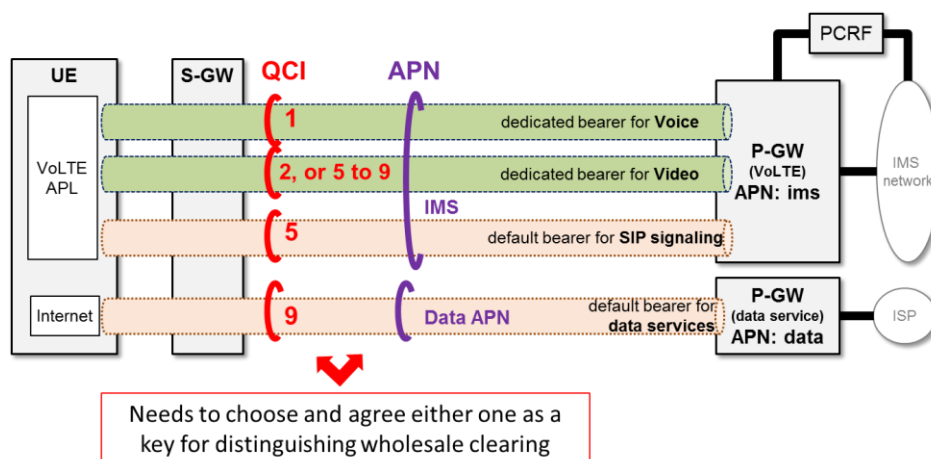

Figure 2: Wholesale clearing based on QCI or APN

The S8HR model, while resembling existing LTE data roaming, enables the use of different charging models for IMS-based services. These models allow operators to differentiate IMS traffic from regular LTE data. Charging for IMS services can be based on:

- Access Point Name (APN)
- Quality of Service Class Identifier (QCI)
- Actual service (Data)

All these approaches are valid and already in use by various operators. However, the chosen charging model must be mutually agreed upon by roaming partners, taking into account each party's capabilities.

Impact of VoLTE on Charging Record Volume

The deployment of VoLTE significantly increases the volume of charging records. This increase is primarily driven by:

- The need for a permanent IMS registration session
- Generation of partial records
- Subscriber mobility (& Network topology)

Although operators cannot control how roaming partners generate charging records, there are industry-recognized practices to reduce the number of CDRs for inbound roamers. These include:

- Grouping charging records by QCI per IMSI over a 24-hour period
- Grouping QCI5 traffic (registration, signaling, SMS) per IMSI over a 24-hour period
- Discarding all QCI5 records
- Aggregating all IMS traffic (per APN "ims") per IMSI over a 24-hour period

Charging by QCI: Considerations and Standards

Differentiating IMS services by QCI requires either:

- The use of TAP version 3.12, as specified in GSMA PRD TD.58^[15], which includes fields needed for QCI-based differential charging; or
- Adoption of a Billing and Charging Evolution (BCE) process, as outlined in GSMA PRDs TD.201^[16] and TD.202^[17]

Operators choosing to implement QCI-based differentiation are advised to assess its potential impact on CDR and partial record generation. Some operators have reported an increase in VoLTE CDRs due to QCI-based separation.

BA.12 Constraint on Partial Record Creation

According to GSMA BA.12, there is a rule limiting the generation of partial records to two per 24-hour period. However, this rule may not be enforceable in practice when charging session IDs are shared across QCI values. Since there is no guidance on which QCI should take precedence, this can result in non-compliance with the BA.12 constraint.

4.2 Signalling

As the HPMN has visibility of all calls in real time, the HPMN can retail charge based on TAS (Telephony Application Server) billing records for voice calls. SMS can also be part of IMS SIP (Session Initiation Protocol) signalling used over default IMS bearer or sent in the NAS signalling; in both cases, SMS should be rated based on SMSC (Short Message Service Centre) billing records.

4.3 Retail Presentation

4.3.1 Billing from Home Network Elements

To bill the S8HR VoLTE Roaming CDRs, the HPMN needs to modify its home back office systems to identify VoLTE roaming calls separately from on-network VoLTE calls. Information on identifying serving networks can be found in IR.65 section 6.2.1.

4.3.2 Time Zones

For S8HR, the ideal solution is for the NetLoc (“Network Provided Location Information for IMS”) information element to be sent by the VPMN to the HPMN. However, this information element is optional and is not provided by all VPMNs.

In addition, where the VPMN has more than one-time zone in the country, retail bills could be incorrect as all calls would be recoded in a single time zone, regardless of the actual time zone applicable to the call.

There are thus three potential scenarios:

- Scenario 1: VPMN provides “NetLoc”. The HPMN is thus provided with the correct time zone. This is the correct and preferred solution.
- Scenario 2: VPMN does not provide “NetLoc” but the HPMN has a time zone offset table indexed by the visited country. In this case, the time may be incorrect if there are multiple time zones in the visited country.
- Scenario 3: Visited Network does not provide “NetLoc, and the HPMN does not have an entry for the visited country in the time zone offset table. This scenario should not happen as the HPMN should populate the time zone offset table for all countries with which it has a VoLTE Roaming agreement.

In terms of the impact on retail billing, it is recommended that:

- Call are stamped with the correct local time for scenario 1.
- Calls are stamped with a single country local time from the time zone offset table for scenario 2, which may be incorrect if multiple time zones in that country.
- Calls are stamped with an unknown time for scenario 3.

Further technical details are provided in section 5.9.

[Next Section \(Technical Issues for S8HR VoLTE Roaming\) >](#)

5 Technical Issues for S8HR VoLTE Roaming

5.1 VoLTE/IMS Issues

The following generic VoLTE/IMS issues have been identified as being impacted by the introduction of S8HR based VoLTE roaming:

- Enable/Disable IMS-APN when roaming
- IMS Registration
- QoS considerations
- Determination of Location / Time Zone (TZ)
- IPv4/IPv6 compatibility
- Local Number Translation & Routing
- SRVCC Handling
- Regulatory Impacts on IMS

See annex B for further details.

5.2 SMS Service

There is a need to be support the SMSoIP (SMS over IP) service to inbound VoLTE roamers using S8HR.

Note 1: It still possible for VoLTE roamer customer to continue to use a legacy solution to transport Short Message if SMSoIP is not supported by the HPMN. This option is not described in this document.

As a prerequisite, SMSoIP must be supported in the HPMN and there would typically be a VoLTE roaming agreement in place between the HPMN and VPMN.

Note 2: It is possible to support SMSoIP using only a LTE roaming agreement and without VoLTE roaming agreement. In this case, IMS “well known” APN shall be used to register the user in the HPMN using QCI=5 for the IMS signalling bearer – see annex B.2.

See annex C for further details covering Service Enablement, SMS billing and example message flows.

5.3 Emergency Calling

An inbound roamer using S8HR VoLTE roaming must be able to initiate an emergency call to an operator in the VPMN.

As described in 3GPP TS 23.167 [1], the two options for Emergency Call (EC) are:

- EC using Circuit-Switched Fallback (CSFB)

- EC via IMS

The UE must be able to identify emergency numbers as described in section 10.1.1 of 3GPP TS 22.101 [23] (so-called UE-detected emergency calls). In addition, non-UE detected emergency calls must also be handled.

For UE detected emergency calls, the UE must support emergency call procedures via both CS-domain and IMS, and support domain selection as described in 3GPP TS 23.167 [1] Annex H.5.

It is assumed that EC using CSFB will be typically used as the starting point as it is based on the current mechanism utilized around the world. However, EC using CSFB is not applicable for a 4G-only operator and it is assumed that emergency call services will migrate over time to IMS.

Emergency Calling Support

Scenario	Network Features			Device Features	Outcome
	LTE Only Network	VoLTE & PS Emergency calls	Accept anonymous registration	Device is VoLTE capable	
A	Y	Y	Y	Y	PS emergency
B	Y	Y	Y	N	PLMN Reselection (Note 1)
C	Y	Y	N	Y	PLMN Reselection (Note 2)
D	Y	N	N/A	-	PLMN Reselection (Note 3) (Note 4)
E	N	Y	Y	Y	PS emergency
F	N	Y	Y	N	Rat reselection and CS emergency
G	N	Y	N	Y	Rat reselection and CS emergency
H	N	N	N/A	N/A	Rat reselection and CS emergency

Note 1: The UE will attempt to select a network that support emergency calls.

Note 2: The UE will attempt an emergency call in PS, but due to lack of credentials the emergency call will fail on that network

Note 3: If the UE is informed that PS emergency calls are not supported, it will perform a PLMN selection prior attempting to set up an emergency call

Note 4: a voice centric device may decide (depending on implementation) not to register on an LTE-only network without voice capabilities.

Full details can be found in 3GPP specifications: especially TS 22.101, TS 23.167

Annex D provides further details on IMS based EC.

5.4 Regulatory Aspects

There are a number of regulatory aspects that are impacted by S8HR VoLTE roaming:

- Legal Intercept,
- Data Retention,
- Priority Services.

It should be noted that all regions/countries have different regulations and MNOs need to consult with their internal legal and specific country/local regulations for each of the above topics.

See Annex E for further details.

5.5 Testing Considerations

Network Testing for VoLTE Roaming is covered in GSM PRD IR.25 [9] & TADIG Testing for VoLTE Roaming is covered in GSMA PRD TD.50 [14].

Device test cases are in GSMA PRD TS.11 [18] and 3GPP TS 34.229 [3]. The former is used for field trial testing and the latter for more in-depth certification testing.

However, a number of practical problems have been reported in the testing of VoLTE/Roaming:

- OEM Blocking of VoLTE – open market devices deliberately disable their VoLTE/IMS capability on insertion of a SIM indicating a network (MCC/MNC) that has not been tested sufficiently. Such blocking is carried out by the OEM to prevent a bad user experience when connecting to an « untested » network and resulting reputational damage to the device. Such blocking also tends to impact to a greater extent on smaller MNOs.
- OEM Blocking of VoLTE Roaming – This issue is believed to be caused by historical reasons due to incorrect setting of the VOPS (Voice over PS) indicator.
- Device Settings – It is observed that there is a testing overhead due to the need to test the different device settings preferences of a given MNO for a given device. Despite a previous GSMA initiative to standardise the configuration parameters in GSMA PRD TS.32 [19] in order to facilitate interoperability between devices and networks, there is still too much deviation between different MNOs and a need to test all combinations.
- Neither TS.11 [8] nor 3GPP TS 34.229 [3] takes any account of the device configuration settings as described in GSMA PRD TS.32 [19] nor cover the testing of networks.
- Shipping of Devices – It is noted that there is currently a need to ship devices around the globe to enable them to be tested in a given network with its settings reflecting the preferences of that network. The shipping of devices incurs inherent delays and costs (e.g. import duties).

- Testing Overhead – There are over 1900 VoLTE capable devices and currently circa 220 VoLTE launches, with variations between the MNOs regarding their TS.32 [19] parameter settings. VoLTE Roaming enables any device to appear in any network. The need to test “everything everywhere” is overwhelming. There is a need to have a methodology and testing strategy to break down the problem into a manageable task.
- Lack of Education / Confusion – MNOs complain that it is not clear exactly what needs to be tested in order to deploy VoLTE Roaming.

In order to address these challenges, the NG GERI WG has defined a VoLTE Roaming test eco-system and a test methodology to be applied to that eco-system.

See annex F for further details.

5.6 IR.21 Impacts

GSMA PRD IR.21 [8] is impacted due to S8HR VoLTE Roaming as follows:

- VoLTE Roaming Information:
 - VoLTE Roaming architecture supported as VPMN and HPMN
 - SRVCC support as VPMN and HPMN
 - Emergency call handling; either via CS or IMS, and list of local emergency numbers in use at the VPMN
 - Lawful Interception / Data retention; whether VPMN requires no encryption
 - EPS QoS to be enforced, where the details need to be described in “LTE Roaming Information” as described below.
- LTE Roaming Information related to VoLTE Roaming:
 - (list of) LTE QoS profiles; that includes the QoS parameters for “ims” APN as indicated for “EPS QoS to be enforced” (see also section 5.3).
 - SMS ITW; Specifies whether SMS is delivered using IMS (SMS over IP), or by legacy means (SMS over NAS)
 - Voice ITW; Specifies how voice is supported in the PMN, either CSFB, VoLTE or other
- LPWA Roaming Information dedicated to VoLTE Roaming:
 - applicability of VoLTE roaming when using LTE-M. Support of VoLTE roaming with LTE-M as VPMN and HPMN is marked in for LPWA roaming aspect.

See Annex G for further details.

5.7 Fraud Systems

With S8HR VoLTE roaming, the VPMN can see QCI1 flows and therefore is voice flow aware despite the VPMN not being IMS Service Aware. The HPMN that is handling the call must ensure that the roaming calls being handled by the home network are appropriately identified within its Fraud Management Systems (FMS) as roaming. This will likely require changes to the FMS feeds.

Next section (VoLTE Roaming Checklist) >

Back to navigation ^

Annex A VoLTE Roaming Checklist

These questions are all optional. The checklist can be modified to fit the operator's needs with additions or deletions.

Please note GSMA PRD AA.13 [5] Annex C14 contains the VoLTE Roaming Agreement Annex and a Commercial Launch Letter can be found as an Annex to GSMA PRD BA.50 [6].

VoLTE Roaming Questionnaire:

Questions	MNO A	MNO B (sample answers in italics)
Deployment Status & Readiness Questions:		
Have you launched IMS-based VoLTE services on your network?		<i>Yes, VoLTE services launched on mm/dd/yyyy. No, planned launch of VoLTE services on mm/dd/yyyy.</i>
What architecture will you use for VoLTE roaming enablement?		<i>S8HR</i>
Can you share your VoLTE coverage map?		<i>Coverage information is available at https://www.MNO_B.com/maps/wireless-coverage.html</i>
VoLTE Roaming Status - have you launched VoLTE roaming yet? If so, a. inbound VoLTE roaming? B. outbound VoLTE roaming?		<i>VoLTE roaming is bilaterally launched in x countries Country 1, Country 2, Country 3. . .) with Y carriers.</i>
When will you be ready to start commercial testing for inbound VoLTE roaming? Are there any restrictions on inbound roaming?		<i>mm/yyyy. Note: Do not have CSFB.</i>
When will you be ready to start commercial testing for outbound VoLTE roaming?		<i>mm/yyyy. Note: list restrictions if needed</i>
Technical Questions:		
Are you compliant with the recommendations in IR.88 [12]? If not, what are your deviations?		<i>MNO B is compliant with IR.88 [12] with a deviation of QCI 8 for video and for CODEC s MNO B only allows 0-3. MNO B provides up to 512kbps minimum for inbound VoLTE roamers. MNO B outbound roamers require 51kbps minimum for VoLTE on the serving network</i>
What QCI do you support on your network?		<i>Support QCI=1 for VoLTE, QCI=2 for ViLTE, QCI=5 for SIP Signaling and QCI=9 for internet access.</i>
Which IPX provider(s) will be used for VoLTE roaming?		<i>Have several IPX providers; specific provider subject to bilateral discussion between roaming partners.</i>
What is your Emergency calling policy for inbound roamers?		<i>Provide emergency services via VoLTE and CSFB.</i>

What emergency numbers does your network support? If your MME announces your emergency number(s) list, does it follow the standards?		<i>Network supports both 911 and 112. MME does not announce emergency number(s) list.</i>
What is your legal/regulatory requirement for support of Lawful Intercept? Does the VPMN require the HPMN to turn IMS encryption off?		<i>Yes, VPMN requires IMS encryption turned off for inbound roamers. No, do not require the HPMN to turn off IMS encryption</i>
Does your network support IPv6 PDN type?		<i>Yes, IPv6 is supported.</i>
Do you support the NetLoc procedure to provide time zone information?		<i>Yes, NetLoc is currently supported and MNO B requires NetLoc for its outbound roamers</i>
Additional Supported Services Questions:		
What method of SMS are you supporting for VoLTE?		<i>SMS over IMS SMS over SGs (EPC)</i>
Do you support SRVCC for inbound roamers to your network? *		<i>Yes No</i>
* Only applicable where HPMN supports SRVCC (as it requires both partners for this to be successful (device and network)		
If the visited network broadcasts multiple MCC/MNCs, which MCC/MNC will be in the ULI field. Are these MCC/MNC's being used by the ECGI provided on the IR.21[8]?		
End to end QoS, especially over IPX - Any E2E QoS requirement on IPX carrier (e.g. DSCP tagging based on GSMA IR.34[10])		<i>Yes, we can.</i>
Wholesale Charging Questions:		
Do you support the standard volume-based charging for VoLTE?		<i>Yes</i>
Do you charge by APN, QCI or both?		<i>Can charge by APN or QCI</i>
Do you support TAP 3.12? (note: 3.12 and beyond supports VoLTE)		<i>Yes.</i>
Can you support a BCE file exchange and settlement process?		<i>Yes.</i>
IREG/TADIG Planning:		

Testing environment (On Production or Lab environment)		On Production
What devices (make, model) do you offer to your subscribers that are VoLTE-capable?		<p><i>Total XX models as of dd/mm/yyyy:</i> <i>iPhone: iPhoneX, iPhone 8, iPhone 7, iPhone 7 Plus, iPhone 6s, iPhone 6s Plus, iPhone SE.</i> <i>Android: LG G3 Vigor, LG G5, LG V10, LG V20, LG K10; Samsung Galaxy S7, Samsung Galaxy S7 Edge, Samsung Galaxy S7 Active, Samsung Galaxy S6, Samsung Galaxy S6 Active, Samsung Galaxy J3, Samsung Galaxy S5; HTC One A9; PRIV by Blackberry; Microsoft Lumia 950, Microsoft Lumia 640 XL; Kyocera DualForce XD.)</i></p>
Are additional SIMs required for testing or can existing LTE SIM cards be modified and used?		<p><i>MNO B does not require additional SIM cards be shipped. It plans to modify existing LTE cards by adding VoLTE profile.</i></p>
Any needs of VoLTE handsets shipped to roaming partners for VOLTE roaming?		<p><i>Yes - # of devices and types are To Be Determined, but MNO B is anticipating device/SIM exchange for IREG/TADIG testing.</i></p>
Are you compliant with IR.25[9] VoLTE Roaming for IREG testing? If not, please provide your test plan.		<p><i>Yes, use PRD IR.25[9] and/or a condensed version for IREG/TADIG testing, but may seek to perform additional testing.</i></p>
Do you restrict test SIMs during VoLTE roaming testing and if so how?		<p><i>MNO B can restrict test SIMs just for IREG/TADIG testing.</i> <i>a. For Outbound roaming, if no, how is this enforced? Is Screening of IMS APN by HSS?</i> <i>b. For serving network, do you restrict MMEs to test IMSI's only during IREG testing?</i></p>
Do you send TD test files?		<p><i>Have capability to screen out IMS APN except for test SIMs used during testing of IREG.</i></p>
LTE/eUTRAN, HSS, EPC (SGW/PGW/PCRF) and IMS infrastructure vendor		<p>Vendor 1 and Vendor 2</p>
Contacts		
Contacts		<p><i>1. Name 1 / employee1@MNO_B.com / +X.XXX.XXX.XXXX / Title 1</i> <i>2. Name2 / employee2@MNO_B.com / +X.XXX.XXX.XXXX / Contact Title (VoLTE Roaming)</i> <i>3. Name3 / lamGroot@MNO_B.com / +X.XXX.XXX.XXXX / Technical Contact-IREG Coordinator</i> <i>4. Name4 / employee4@MNO_B.com / +X.XXX.XXX.XXXX / Technical Lead – Implementation/Onboarding</i></p>

[Next section \(VoLTE/IMS Issues Impacted by S8HR VoLTE Roaming\) >](#)

Annex B VoLTE/IMS Issues Impacted by S8HR VoLTE Roaming

This annex complements section 5.1 and provides recommendations/solutions to VoLTE/IMS related issues that are impacted by S8HR VoLTE roaming. References are also provided to 3GPP specifications and to NG PRDs.

A summary of MME and HSS functions is also provided.

B.1 Enable/Disable IMS APN

The well-known IMS-APN should be allowed if IMS services are part of the roaming agreement. This includes voice as well as other services such as SMSoIP. IMS registration should register only permitted services. Therefore:

- The HSS shall enable/disable the IMS APN based on MCC/MNC,
- The MME shall inhibit IMS APN based on MCC/MNC.

The VPMN is not IMS-service aware but can police/block bearer requests over S8 (e.g. not allowing a QCI=1 requests if voice not permitted). See also annex B.3.

B.2 IMS Registration and SIP Sessions

IMS registration is typically provided for voice service but can also be applicable to other IMS services, e.g. SMSoIP.

IMS registration is applicable if the IMS-APN is available (see annex B.2) and:

- For voice, the NAS signaling indicates VOPSI=Yes.
 - VOPSI=Yes is only sent to the UE VoLTE Roaming agreement in place (see GSMA PRD IR.88 section 5.2.2.3)
 - The IMS signaling bearer shall use QCI=5.
- Other IMS services are applicable on the UE – e.g. SMSoIP.
 - SMSoIP shall also use IMS signaling bearer with QCI=5.

If IMS voice/video services are supported in S8HR, then :

- The VPMN must support bearer requests for QCI=1 over S8,
- The VPMN must support bearer requests for QCI=2/8 over S8.

The roaming agreement must specify whether conversational video is permitted and the related QCI. If video is permitted, it is recommended to use a non-GBR QCI.

The UE must respect the VOPSI indicator and not try to register for voice services if VOPSI=No.

B.3 QoS Considerations

As operators deploy VoLTE services on their own network, they will design QoS policy as per their requirements and network design. The QoS policies on the visited network and home network will have differences in most cases. Care must be taken when designing the QoS policy for inbound roamers and communicated early on with the roaming partner. For example, for VoLTE service, some operators have chosen to use GBR (Guaranteed Bit Rate) QCI 2, whereas, some have chosen to use a Non-GBR (typically QCI 8). The QCI values to be supported for roaming are dependent on the roaming agreement. In order to simplify

VoLTE Roaming, it is recommended that standard settings are applicable to all VoLTE Roaming agreements. Such a recommendation is provided in annex E of GSMA PRD IR.88 [12].

If the MME detects that the QoS parameter values from the HSS in the HPMN violate the roaming agreement, it is recommended that the MME downgrade the QoS parameters rather than rejecting the session (see GSMA PRD IR.88 [12] section 7.2.2). Bearer requests for assorted QCI values are made between the VPMN & HPMN over S8 and therefore the roaming agreement must cover which QCI values are permitted.

In addition to LTE data roaming (which is assumed to be supported and use QCI=9), the VPMN must also support requests for the following other QCI values:

- QCI=5 for the IMS signaling bearer,
- QCI=1 for the voice dedicated bearer,
- QCI=2/8 for the video dedicated bearer,
- QCI=1 or 8/9 for the GTT/T.140 bearer - see GSMA PRD IR.92 [24] annex B.

Mismatches in GBR requirements between the HPMN and VPMN can also result in call failure during S8HR VoLTE roaming.

Therefore, it is recommended that there be a standard configuration to be applied to all VoLTE Roaming agreements. For such a configuration, see Annex E of GSMA PRD IR.88 [12].

B.4 Determination of Location / Time-Zone (TZ)

The HPMN P-CSCF can retrieve PLMN Id (MCC/MNC) via PCRF as described in GSMA PRD IR.65 [11] section 6.2.1.

For TZ, the MCC is sometimes sufficient (i.e. only 1 TZ in a country). If multiple TZs, the Network Provided Location Id (netloc) can be used. The IMS layer can retrieve the time zone via Rx or else via S6a. TZ information is required to be compliant with standards.

It is noted that netloc not always supported by the VPMN. The recommended behavior in the HPMN is :

- Use netloc if available,
- Else use table to convert MCC to TZ (which may not be always correct),
- Else set TZ to unknown

B.5 IPv4/IPv6 Compatibility Issues

IP compatibility issues have been observed whereby :

- Not all devices request IPv4/v6 - some only request IPv4 on all APNs.
 - Some UEs request IPv4 only for emergency calls.
- Not all operators support IPv6 – and in this case, if the device only requests IPv4, the request will fail.

GSMA PRD IR.92 [24] section 5.1 states that both the UE and N/W must support both IP versions.

B.6 Local Number Translation & Routing

Local numbers are offered to the HPMN IMS for routing. On receipt of such a local number, HPMN IMS must check for both local (HPMN) service codes and VPMN emergency codes. Local (HPMN) service codes are terminated in the HPMN IMS and VPMN emergency codes result in a SIP 380 response to the UE to enable completion of the emergency call in the VPMN (see annex D.3).

Other VPMN (non-emergency) codes may be supported in the HPMN IMS (e.g. help numbers) but this is part of the roaming agreement. In this case, the HPMN IMS must route call back to VPMN via turning the number into an international format. In practice, most VPMN service codes (e.g. toll free) will not be supported and the call not completed. See GSMA PRD IR.65 [11] section 2.8.3 for further details.

It is possible for there to be a clash between VPMN emergency codes and HPMN service codes. If the VPMN does not notify the UE of local emergency codes, then the number would be handled as local service code at the HPMN. Else, such codes would be treated as UE-detected emergency numbers and terminated in the VPMN.

B.7 SRVCC Handling

SRVCC was introduced to provide voice continuity in the early days of VoLTE deployment where LTE coverage was patchy and the voice call was transferred to legacy RAN and CS-voice on moving out of LTE coverage.

SRVCC is an interim solution that makes less and less sense as LTE coverage increases. Whilst, 3GPP has defined how to do SRVCC for S8HR VoLTE Roaming, issues have been observed (e.g. more calls being dropped when using SRVCC than not using SRVCC).

It is recommended that SRVCC is not used for roaming UEs. SRVCC can be blocked in the MME/HSS. It can also, if required, be permitted on the basis of the individual roaming agreements to enable SRVCC to be applied to some inbound roamers.

SRVCC is described for S8HR in GSMA PRD IR.65 section 2.12 which states that SRVCC be allowed/disallowed on the basis of the individual roaming agreement and also describes how the MME/HSS can enable/disable SRVCC (see Annex A).

B.8 Regulatory Impacts on IMS

Regulatory matters are covered in annex E.

However, there is an IMS related impact as some VPMNs wish to perform legal intercept of the voice & signaling for S8HR inbound roamers whilst others do not. This impacts on whether IMS encryption is switched on/off at the HPMN IMS.

Therefore, S8HR roaming partners are split into 2 groups with encryption being enabled for one group and disabled for the other group.

See section 2.4.3 of GSMA PRD IR.65 [11].

B.9 Summary of MME and HSS Requirements

This MME must:

- Sends VOPSI=Yes to UE only if VoLTE roaming agreement in place.

- Polices IMS APN as per the roaming agreement
- Polices QoS parameters as per roaming agreement – downgrading if necessary rather than rejecting
 - Special case for WPS where there are 2 groups of QoS settings
- Polices permitted QCI to be requested over S8 as per roaming agreement
- Prevents SRVCC for inbound roamers via interaction with HSS (UE-SRVCC-Capability AVP being absent or set to zero in ULR message)
- Support “netloc” via S6a and S11
- Provides local emergency numbers to inbound roamer as per the roaming agreement and taking account of any clash with HPMN service codes
- Send the EMC BS indicator to the UE during the attach and Tracking Area Update procedures to inform the UE whether IMS based emergency call is available.

The HSS must:

- Set differentiated QoS parameters (i.e. from non-roamer case) as per roaming agreement
 - Special case for WPS (Wireless Priority Services) where there are 2 groups of QoS settings – see annex E.3.
- Prevents/allows SRVCC for outbound roamers via interaction with MME (no STN-SR AVP in ULA and IDR messages)
- Support “netloc” via interaction with MME.

Next section (SMSoIP) >

Annex C SMSoIP

This annex provides further details on SMSoIP covering :

- Service Enablement
- Billing,
- Message Flows.

C.1 Service Enablement

The SMSoIP service is dependent on a number of UE configuration parameters defined in GSMA PRD TS.32 [19]:

- SMS_Over_IP_Networks_Indication - SMSoIP Network Operator's Preference (TS.32 IMS parameter VxLTE 1.07), which must be set to "SMSoIP Preferred".
- SMSoIP_usage_policy - SMSoIP Usage Policy (TS.32 IMS parameter VxLTE 1.23), which can be set to "Only with voice" or "Irrespective of voice".
- SMS_Over_IP_Networks_Indication - SMSoIP as a 3GPP PS data-off exempt service (TS.32, IMS parameter VxLTE 1.41) which must be set to "Exempt".

All parameters are valid for both non-roaming and roaming scenarios.

To access the SMSoIP service, the user must register in the HPMN IMS and interact with the HPMN IP-SM-GW. The IP-SM-GW provides protocol interworking between SIP and MAP.

C.2 Billing

The SMS-MO billing is based on CDRs generated via the HPMN IP-SM-GW.

The IP-SM-GW normally uses the P-Visited-Network-ID header in the SIP signalling to provide location information in CDR. This information is filled by the P-CSCF but in the S8HR context, P-CSCF is in the HPMN and the real customer location is unknown. Therefore, for S8HR VoLTE Roaming, the HPMN P-CSCF retrieves the PLMN-ID from the PCRF (as described in Annex B.4) and forwards the PLMN-ID in the SIP P-Visited-Network-ID header which can be used to determine customer location in the IP-SM-GW CDR.

If an operator wants to continue to use the SMSC CDRs, then specific customizations are required. A possible SMSC CDR customization is shown below.

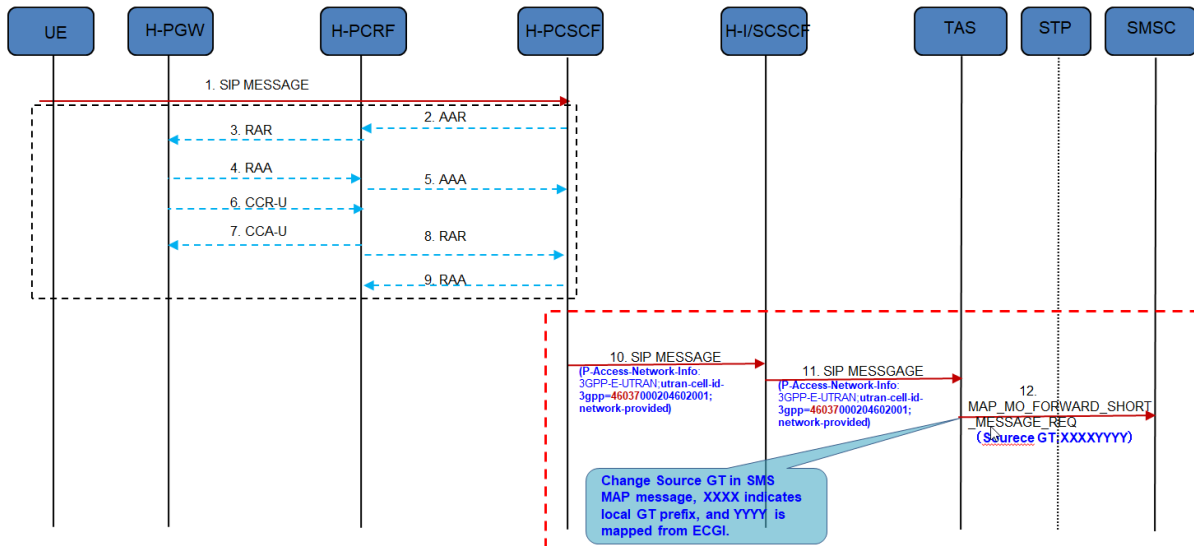

Figure 3: SMSC CDR Customization

- GT code is reused.
- The proposal is similar to existing CS solution.
- IP-SM-GW needs to change source GT in SMS MAP message using the format: XXXXXXX, XXXX indicates local GT prefix, and YYYY is mapped from ECGI.
- SMSC needs to get the source GT and record it in SMS CDR, and BSS will identify whether this CDR is a roaming CDR or not based on the YYYY in the source GT.

C.3 Message Flows

Example message flows are shown for IMS registration, SMS-MO and SMS-MT. In all cases, for S8HR VoLTE roaming, the interaction is between the UE and HPMN IMS.

IMS Registration

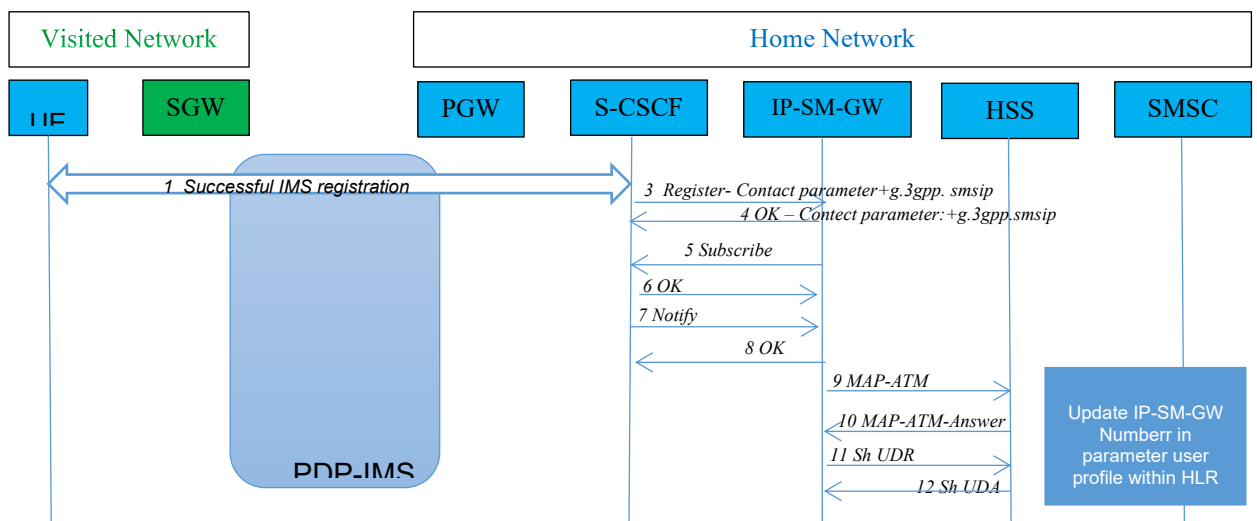

Figure 4: IMS Registration

SMS-MO

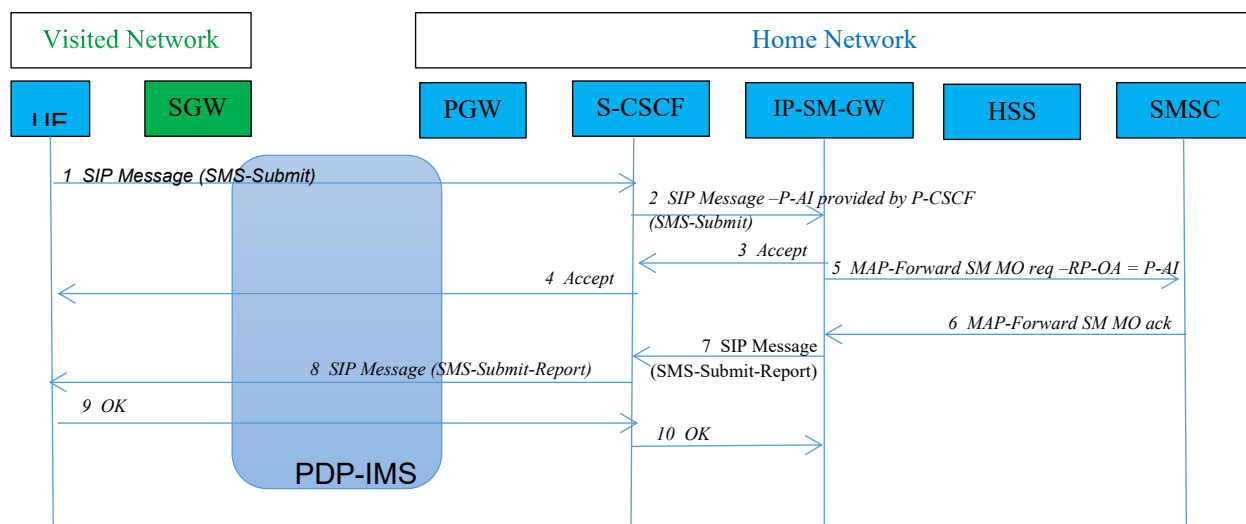

Figure 5: SMS-MO Message Flow

SMS-MT

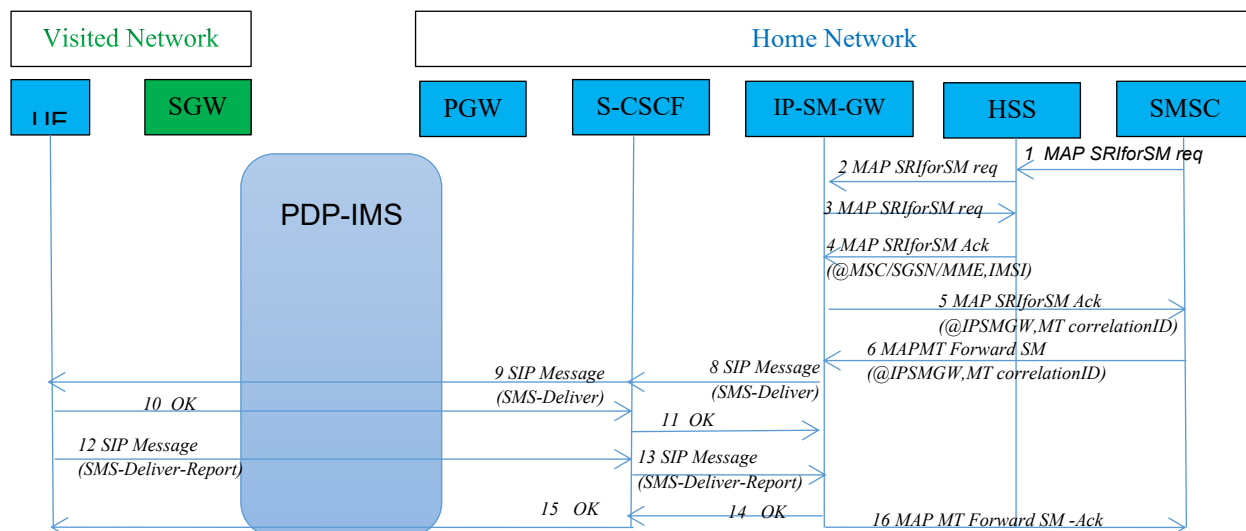

Figure 6: SMS-MT Message Flow

Next section (IMS Emergency Call for S8HR Inbound Roamers) >

Annex D IMS Emergency Call for S8HR Inbound Roamers

D.1 PS Domain Selection

On detecting an emergency call, the UE performs domain selection. Selection of the PS domain for IMS emergency call is based on the EMC BS (Emergency bearer services) indicator sent by the MME to the UE during the attach or Tracking Area Update procedures. The UE selects IMS emergency call if it receives EMC BS = 1 (supported). If the network indicates EMC BS = 0 (not supported), then the terminal selects CSFB for emergency call. The EMC BS indicator can be set per IMSI, i.e. inbound roamers can be handled differently than domestic users.

D.2 IMS EC Procedures

If the PS-domain is selected, then the UE performs the following steps:

- Perform emergency attach,
- Perform emergency IMS registration as described in section 5.1.6.2 of 3GPP TS 24.229 [20], which is assumed to be rejected with a 403 response (due to there being no inter-IMS interface to the HPMN to authenticate the user for the emergency IMS registration) with an XML body indicating that anonymous IMS emergency call is permitted,
- Perform anonymous IMS emergency call as described in section 5.1.6.8.2 of 3GPP TS 24.229 [20].

The anonymous IMS emergency call is handed by the VPMN IMS and the call gets routed to the correct PSAP in the visited country. The VPMN IMS must permit anonymous IMS emergency calls for inbound S8HR VoLTE Roamers if CS emergency call is not available – else there is no emergency service to inbound roamers. GSMA PRD IR.65 [11] section 2.9.1 describes the impact on the VPMN IMS to support emergency call for inbound S8HR VoLTE roamers.

GSMA PRD IR.88 [12] section 6.4.1 recommends that the applicability of IMS emergency services is agreed between the VPMN and the HPMN in the IMS voice roaming agreement.

D.3 Non-UE Detected Emergency Calls

For non-UE detected emergency calls, for S8HR VoLTE Roaming, the call would be routed to the HPMN IMS which shall first check for HPMN service codes followed by VPMN emergency codes. If a VPMN emergency number is detected, the HPMN IMS shall reject the SIP INVITE with a 380 response with XML body indicating Alternative-Service of “emergency”. On receipt of the 380 response, the UE shall behave as for a UE-detected emergency call. The HPMN IMS is assumed to be aware of the emergency digit strings in the VPMN as described in 3GPP TS 24.229 [20] section 5.2.10. GSMA PRD IR.65 [11] section 2.9.2 describes the impact on the HPMN IMS in support of non-UE detected emergency calls.

D.4 Managing VPMN Specific Emergency Codes

Local legislation in some countries requires the support of additional emergency call numbers to inbound VoLTE roamers.

Examples of such additional numbers to the standardised emergency numbers include:

- specific national emergency numbers and services (e.g. 110 for fire, 113 for ambulance)
- additional numbering plan requirements (e.g. best fit dialling, where for example 11234 shall match 112).

The standard mechanism to indicate additional emergency numbers to UEs is via the Emergency Number List and Extended Emergency Number List which is provided by the MME to the UE during the attach and Tracking Area Update procedures. The UE then uses those numbers in addition to the emergency numbers stored on the USIM and/or UE itself to detect if the dialed number is an emergency number. The UE is aware of the additional emergency number in idle mode and can provide additional user experience, e.g. to allow a specific emergency service while the phone is locked.

A second option is to utilize the SIP 380 Alternative Service response by the HPMN IMS to inform the UE that the number is an emergency number. In this case the UE is only aware of the emergency call on receipt of the SIP 380 response and then behaves as for the UE-detected emergency call.

The following additional technical measures are proposed to enable VPMNs and HPMNs to handle the national emergency numbers of the VPMN country.

- The VPMN must be able to differentiate the list of emergency numbers provided by the network to the UE on attach on a per roaming agreement basis.
- The HPMN must be able to apply number screening for emergency numbers with a match against an emergency number list per VPMN/HPMN country. If a match is found, the HPMN shall reject the call with SIP 380 Alternative Service response. A list of emergency service identifiers for all countries can be found in annex F of GSMA PRD NG.119 [13].

National specific emergency numbers in the VPMN country can overlap with numbers in the numbering plan of the HPMN, e.g. with service numbers or other private numbering plans.

In case of such overlap, the following principles may be applied for the handling of national emergency call on a per roaming agreement basis:

- If there is an overlap of a given national emergency number of the VPMN country with a number in the numbering plan of the HPMN and both parties agree not to offer the national emergency number to inbound roamers, then the national emergency number is excluded from the emergency number list sent to subscribers of the HPMN on attach. In this case calls to the given number will be established with the HPMN of the inbound roamer.

- If the capabilities of the MME for the control of an national emergency number is not sufficient (e.g. number too long), then the national emergency number can be excluded from the emergency number list sent to inbound roamers. Calls to a given number will thus be attempted with the HPMN which will apply number screening and will reject the call attempt with the SIP 380 Alternative Service response to trigger an emergency call attempt in the VPMN.

It is recommended that roaming partners analyse their emergency call requirements on the basis of these principles and apply the technical measures accordingly.

See also Section 2.9.2 of GSMA PRD IR.65 [11] which discusses the implications of sending/not sending the local emergency codes to the UE.

D.5 Emergency Calling in Limited Service State

As stated in GSMA PRD IR.88 [12] section 6.4.1, IMS emergency services can also as per policy of the serving network be provided to UEs in limited service state.

Limited service state is defined in section 3.5 of TS 23.122 [26] and refers to the availability of a specific service in the network. Limited service state includes the following:

- UEs with a USIM that cannot be authenticated,
- UEs without a USIM (“SIM-less”).

UEs in limited service state can only perform an IMS emergency call without emergency registration. This is also applicable to UEs with reduced/limited voice capabilities, e.g. inbound roamers where there is no VoLTE Roaming agreement in place.

Upon detecting an emergency call request, a UE in limited service state shall check the support for PS and CS emergency in the cell in which the UE is camped:

- If the cell supports PS emergency service, the UE shall initiate an IMS Emergency call set-up;
- If the cell supports CS emergency service, the UE shall initiate a CS emergency call set-up;
- If the cell does not support any emergency service, the UE shall initiate a PLMN scan.

The network may allow or reject the emergency call set-up based on local policy and regulations.

D.6 eCall

A variant of emergency calling that must also be considered is that of eCall.

eCall is a European initiative to reduce response times in the event of a serious road traffic accident. An eCall system can initiate either an automatic emergency call as well as a manually initiated eCall. Original eCall standards were based on CS technology with use of an in-band modem to transfer the eCall Minimum Set of Data (MSD) comprising such things as location, vehicle identity etc.

Subsequently, 3GPP standards were enhanced to support an IMS based version of eCall with the MSD carried in an XML body using procedures in IETF RFC 8147. There is also the capability to exchange additional information to that of the CS-based version.

The LTE network broadcasts support of eCall to the UE. The requirements for IMS based eCall are defined in 3GPP TS 23.167 [1] Annex H.6.

[Next section \(Regulatory Aspects of S8HR VoLTE Roaming\) >](#)

Annex E Regulatory Aspects of S8HR VoLTE Roaming

This annex is focused on the regulatory aspects that may directly impact S8HR VoLTE roaming. The key regulations are defined along with standardized solutions to facilitate support. It is important to note that all regions/countries have different regulations and MNOs need to consult with their internal legal and specific country/local regulations for each of these topics.

E.1 Lawful Interception

E.1.1 Definition

Lawful Interception (LI) is a network function responsible for giving law enforcement officials, such as police, access to ongoing communication flow in the mobile network, according to local regulation. LI has been around since the days of 2G. It can provide authorities with many types of information, such as:

- Identification of the users (A and B party)
- Network provided location information
- Call logs
- Traffic (as audible voice call)
- Traffic (as broadband data)

E.1.2 National Regulation

Lawful Interception needs to be supported for home routed (S8HR) VoLTE roaming according to local regulation as authorities in the visited country may require access to a specific inbound roamer call. In practice, this is handled by the VPMN tapping into the VoLTE call at the SGW, as all the IMS elements are located in the HPMN for an S8HR VoLTE call.

To provide the VPMN the ability to tap a VoLTE call in their network, inner or IMS encryption needs to be disabled. This does not impact message integrity protection. It should also be noted that IPSEC is still used, albeit with a null encryption algorithm.

Turning off IMS level encryption (IPSec confidentiality protection) for outbound VoLTE roamers between UE and P-CSCF for the purpose of the VPMN being able to perform LI has been a sensitive topic when deploying S8HR VoLTE roaming. The impact to user privacy, adhering to local regulatory requirements, as well as compliance with operator internal security guidelines all need to be assessed. It should be noted that in current deployments typically only SIP signalling is encrypted in VoLTE. The actual RTP voice media is only encrypted over the air and is thus not encrypted when passed from the eNodeB to the SGW in the EPC. Therefore, in practice, the key discussion on turning off encryption relates to whether encryption of the SIP signalling traffic is a major concern or not. However, it is clear that the visited country regulation must be followed, otherwise roaming will not happen. Thus, the HPMN must support the requirements of the VPMN. This means that the HPMN will, on a per VPMN basis, decide to use null encryption or not and will typically have 2

groups of roaming partners, depending on whether IMS encryption is disabled or not. See also GSMA PRD IR.65 [11] section 2.4.3.

One challenge for operators related to VoLTE roaming & LI is that the standardized 3GPP Rel-14 model specifies the Xia & Xib interfaces between SGW/BBIFF and LMSIF at a functional level only. Protocol level ("Stage 3") details are not illustrated but rather left open for the vendors to provide solutions. In a multi-vendor network where the PS core is from another vendor than the existing LI system used for CS voice, there may be considerable issues in the integration process between SGW/BBIFF/LMSIF if the intention is to reuse the current LI mechanism also for VoLTE. As MNO's define their approach for VoLTE LI compliance, they need to ensure that the PS-intercept is able to handle SIP/voice packets.

Regulation can vary significantly between countries. Some countries do not have any demands to perform LI for inbound VoLTE roamers, while other countries view VoLTE as equivalent to CS voice roaming. A number of countries are suggesting VoLTE is data service and therefore should be handled as any other data stream or VoIP call. In many localities, regulation for VoLTE calls remain a work in progress as of late 2020.

As the regulations evolve and are developed for all regions, adopting a realistic working assumption, such as reusing the existing LI model for inbound LTE data roamers, and applying that model for inbound VoLTE roamers may hasten deployment efforts. For example, several operators in the Nordics have already launched VoLTE commercially, despite local regulation regarding LI for inbound VoLTE roamers not yet complete.

E.1.3 Solutions

E.1.3.1 Update of the network (Active solution for S8HR LI)

If national regulation demands LI for inbound VoLTE roamers, the MNO needs to update the network. It is recommended to follow the standardized solution according to 3GPP TS 33.107 [25]. See also GSMA PRD IR.65 [11] section 2.4.3.

The standardized solution demands an update of the EPC, so that the SGW supports the BBIFF functionality (Bearer Binding Intercept and Forward Function), it also demands an update of the ADMF, so that it supports the additional LI Mirror IMS State Function (LMISF). Also proven interoperability between the updated EPC and the updated LI functions should be verified. See figure 7 below.

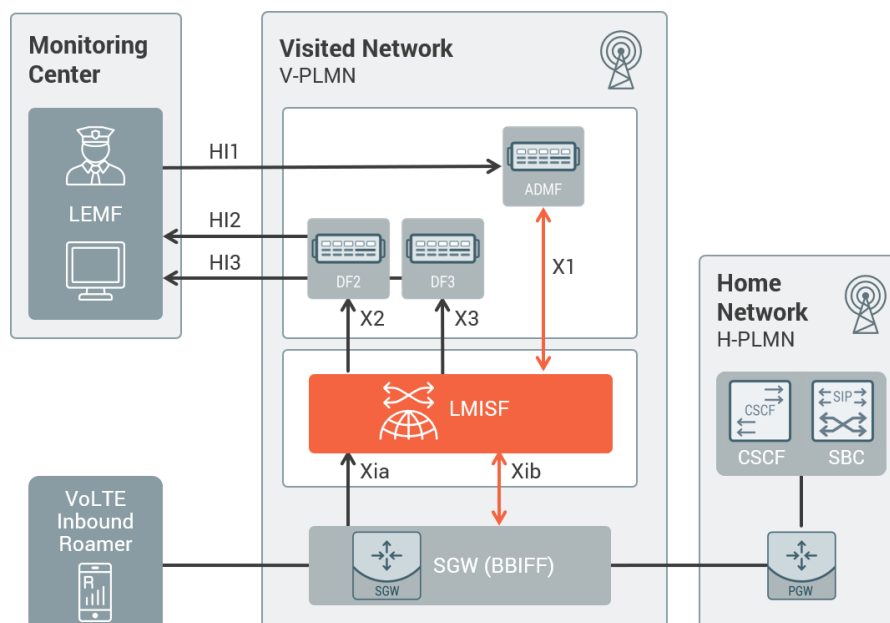

Figure 7: LI S8HR active solution

E.1.3.2 Passive solution for S8HR LI

If national regulation demands LI for inbound VoLTE roamers and the MNO decides not to use the active approach, either because of technical or strategical reasons, a passive solution can be applied.

It should be noted that the passive solution is not described in 3GPP standards. This solution should provide identical behavior on the H-interfaces (HI1, HI2, HI3).

In this case the MNO needs an LI Access Point which investigates the traffic data of the S8 interface in real-time and provides interoperability with the existing LI Mediation System. This access point demands connection to taps and optionally packet brokers which mirror the complete traffic data of the S8 interface. See figure 8 below.

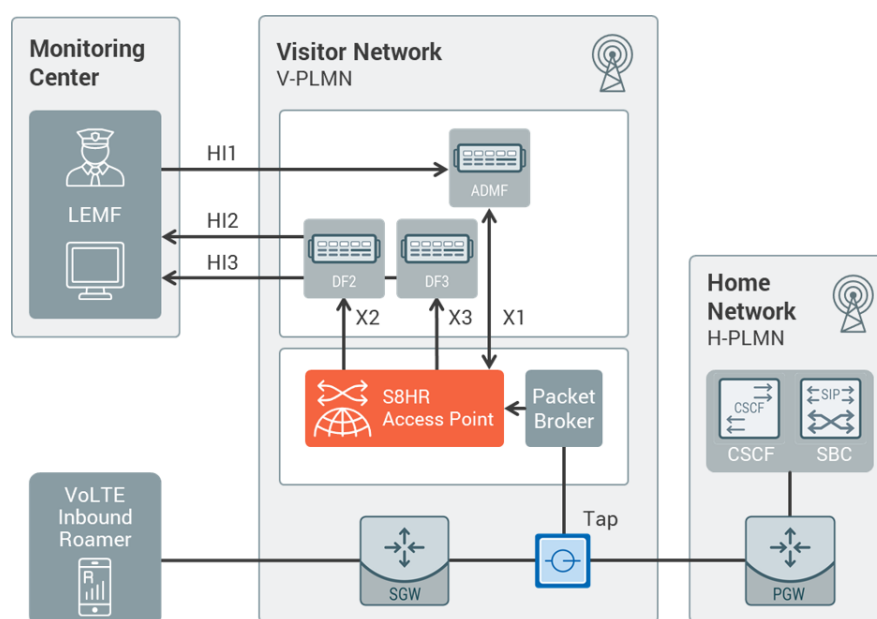

Figure 8: LI S8HR passive solution

E.1.4 Future proof and consideration for 5G

Naming and standards are different in 4G/EPC and 5G/5GC. The S8HR in EPC roaming user plane flow equates to the N9HR user plane flow in 5GC roaming, with the SGW functions being handled by the UPF. The corresponding 5G standard is 3GPP TS 33.127 [22].

At this time, standardization for 5G is not yet finalized, but the solution for LI of inbound VoLTE roamers is expected to remain equal or similar in 5GC. Therefore, it is recommended to verify that any chosen solution is upgradeable to 5G networks.

E.2 Retained Data

E.2.1 Definition

Retained Data mainly relates to retention of location information, time and nature of call, the calling or the called parties of past VoLTE services and providing Retained Data to LEAs on demand. National regulations in many countries require support for Retained Data by network operators.

E.2.2 National Regulation/Solutions

Data Retention (a.k.a. Retained Data) means that the VPMN needs to have the capability to record data that is related to the communication traffic (e.g. location/date/time/duration information, calling and called party identities, etc) via VPMN network nodes without any reliance on the HPMN to forward SIP events or call records. It is closely related to LI since the same network functions are utilized in both cases.

It appears some regulators would like to have the same functions in VoLTE that are currently available in 2/3G CS voice roaming. Thus, Data Retention needs to be supported by VPMN for any inbound roamers before commercial VoLTE roaming can be launched.

If there is a need to record and retain data for all roamers, then traffic cannot be encrypted. This requirement aligns with the LI requirement and allows the ability to access unencrypted SIP signaling. The solutions may be based on enhancements of the solution selected for S8HR LI.

It is very important to note that Data Retention for any entity is under the jurisdiction of a given country and does not extend to entities outside of that country's jurisdiction. While privacy laws have different boundaries and enforcement, data retention does not.

E.3 Priority Services (MPS/WPS)

E.3.1.1 Wireless Priority Services (WPS)

WPS provides voice call priority to select user types during times of network congestion and is a matter regional/national regulation. There is no mandate that WPS be supported in an international roaming scenario. Any provision of priority handling must be clearly included in the roaming agreement. As recommended in GSMA PRD IR.88[12] section 7.2.2, when priority session handling is requested using priority ARP, the VPMN (MME) has the option of not allowing the priority and is encouraged to downgrade the ARP rather than rejecting the session.

E.3.2 Multimedia Priority Services (MPS)

MPS is a session for which priority treatment is applied for allocating and maintaining radio and network resources that includes priority access to signalling and media bearer resources for voice, video, and data (3GPP TS 22.153 [21]) MPS assignment of priority levels is a matter of regional/national and operator policy. According to 3GPP TS 22.153 [21], MPS shall be supported when the Service User is roaming and the visited network and home network support MPS, and roaming agreements are in place for MPS.

An individual authorized to use MPS and who has been granted a user priority level assignment by a regional/national authority (i.e., an agency authorised to issue priority assignments), and has a subscription to a mobile network operator that supports the MPS feature.

E.4 Lawful Intercept Scenarios

Lawful Intercept can be implemented using one of those 4 scenarios shown in the figure 9 below:

1. DPI implemented by Local Authorities based on data interception
2. DPI implemented by V-PLMN based on data interception
3. IMS Active function adapting network flows to IMS LI mediation
4. IMS Passive function adapting network flows to IMS LI mediation

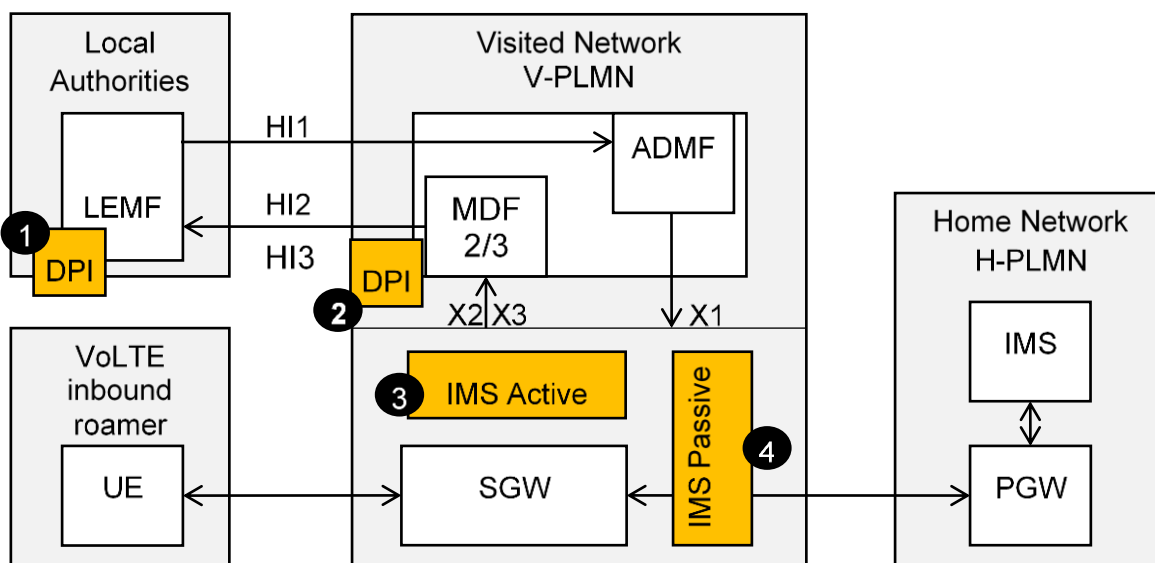

Figure 9: LI Implementation Scenarios

Table 2 below categorizes the four scenarios per standard interfaces and provider:

Scenario	Local Authorities interfaces (Hi)	Network interfaces (Xi)	Provider
1. LA DPI	Data	Data	Local Authorities
2. V-PLMN DPI	IMS	Data	V-PLMN
3. IMS Active	IMS	IMS	V-PLMN
4. IMS Passive	IMS	IMS	V-PLMN

Table 2: Comparison between LI Implementation Scenarios

The following subsections provide additional detail for each of the four scenarios.

1. DPI implemented by Local Authorities based on data interception

This scenario is based on DATA Lawful Interception:

- Rely on existing LTE LI capabilities (SGW, Mediation system, LEMF) to capture target data traffic
- Require DPI capabilities in LEMF to extract IMS signaling and media
- DPI on LEMF can be mutualized for other operators or MVNO services
- Same architecture could be used based on 5G Data
- Voice only Interception not supported
- Supports interception of mobile numbers that are registered in the VPLMN.

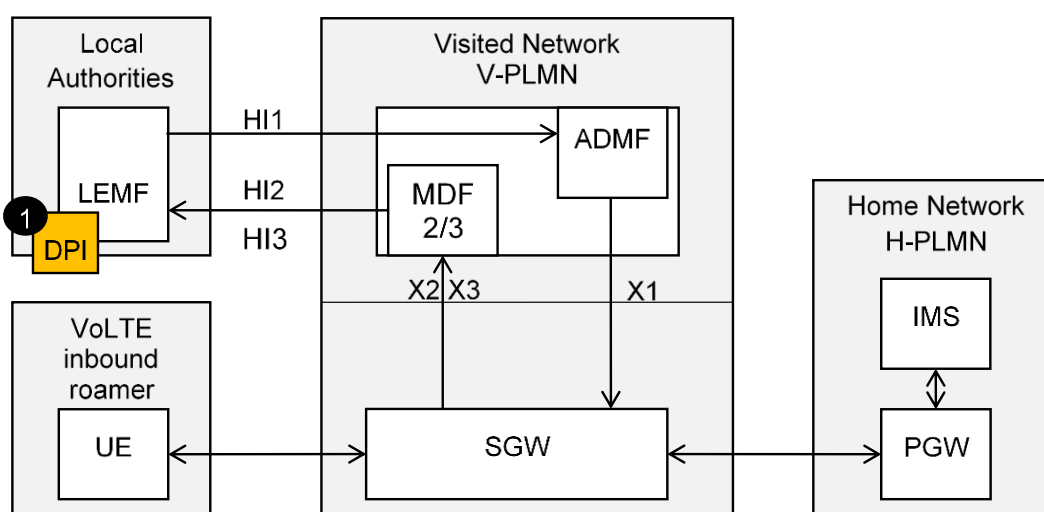

Figure 10: LI Implementation Scenario #1

2. DPI implemented by VPLMN based on data interception

This scenario is based on DATA Lawful Interception, but Hi interface is IMS based:

- Rely on existing LTE LI capabilities (SGW, Mediation system, LEMF) to capture target data traffic
- Require DPI capabilities in LI Mediation System to analyse traffic of the roaming targets and then extract related IMS signaling and media
- Same logic could be used for 5G Data
- Voice only Interception not supported
- Support interception of mobile numbers that are registered in the VPLMN.

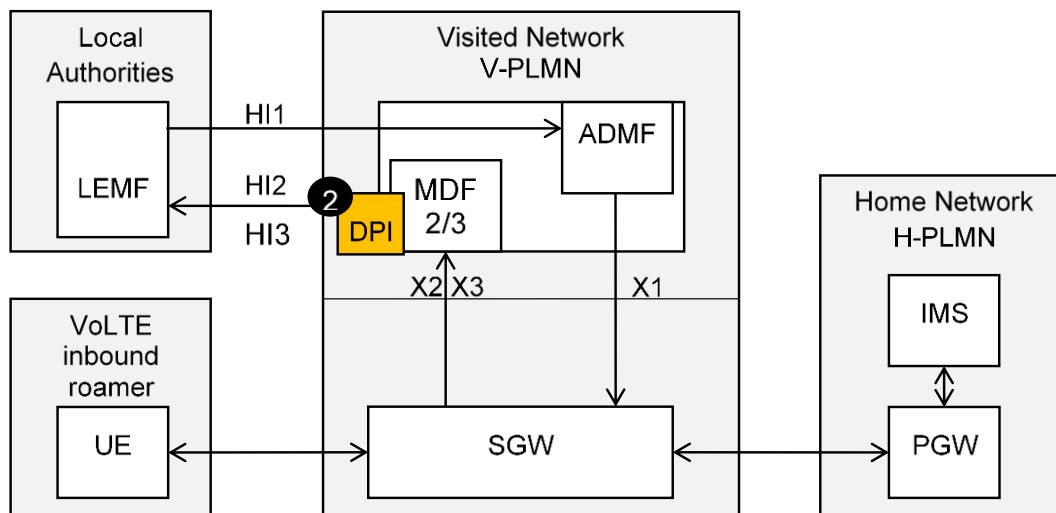

Figure 11: LI Implementation Scenario #2

3. IMS Active function adapting network flows to IMS LI mediation

This scenario is based on 3GPP Lawful Interception designed for S8HR VoLTE roaming:

- Require availability of new function in SGW (BBIFF) and new LI function / product (LMISF)
- Require implementation of proprietary interfaces Xia / Xib
- Require of existing LI mediation to interface with LMISF
- Dependency on SGW providers
- Also applicable for 5G but may need new implementation of Xia / Xib interfaces
- Supports interception of subscribers registered in the VPLMN for both originating and terminating calls.

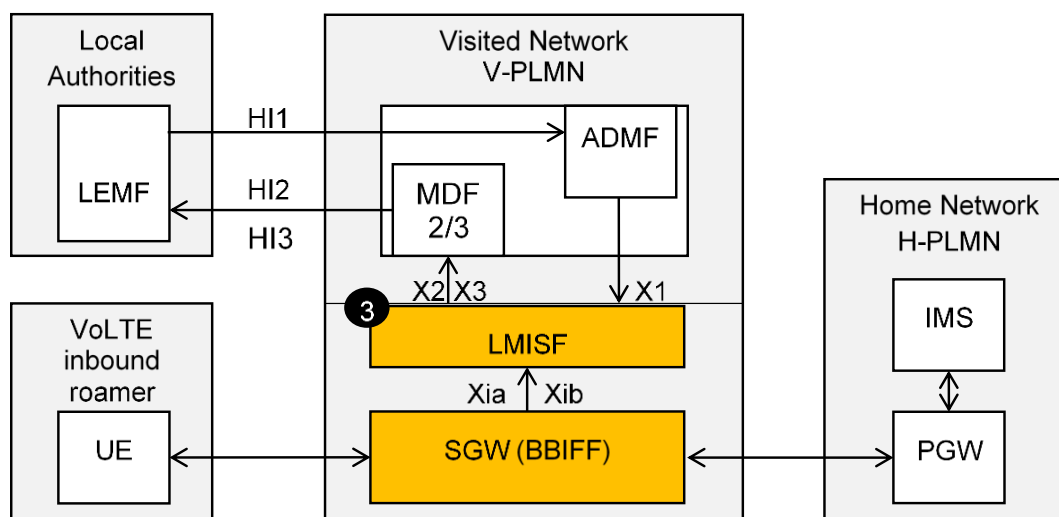

Figure 12: LI Implementation Scenario #3

4. IMS Passive function adapting network flows to IMS LI mediation

This scenario is based on a probing system able to copy the S8HR VoLTE roaming:

- Requires passive taps at appropriate point in the VPLMN to duplicate the complete S8 traffic (including the Roaming IMS signalling and media traffic)
- Requires the use of a SIP/RTP probe to inspect IMS traffic and extract targets traffic
- No dependency on current SGW providers
- Also applicable for 5G (N9 interface)
- Supports interception of subscribers registered in the VPLMN and of both originated and terminated calls..

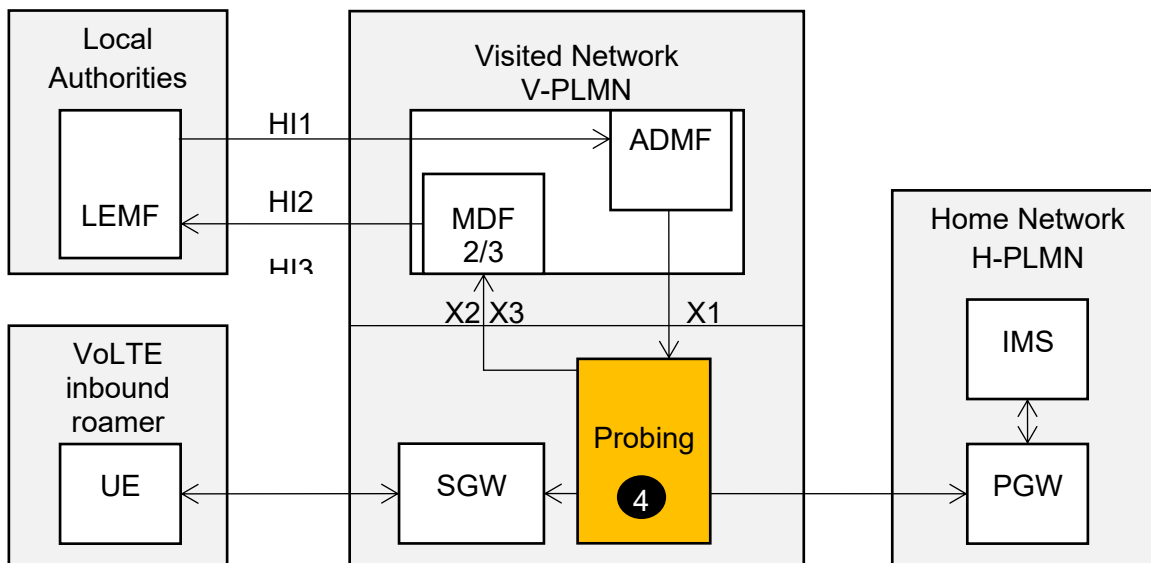

Figure 13: LI Implementation Scenario #4

5. Comparison of the 4 scenarios

Table 3 provides a comparison of the 4 LI Implementation scenarios.

Topics	LI mode	VPMN complexity	Data Retention	Dimensioning issues	Dependency	5G evolution
S1 : LA DPI	Data	None	No	Medium Full Mobile Data required for all Voice targets	Data LI mode might conflict with the request of Local Authorities	Yes, requires support and DPI capabilities for related 5G - Mobile Data specific Handover Interfaces at Local Authorities
S2 : V-PLMN DPI	IMS	Medium	No	Medium Full Mobile Data required	DPI is not a common task for MDF2/3	Yes logic stays identical, but X2 and X3

				for all Voice targets. Adds complexity to the MDF2/3, similar handling like LMISF	and more probe related.	interfaces might change.
S3 : IMS Active	IMS	High	Yes CDRs could be generated by LMISF	Medium Receive all S8HR users' IMS signalling traffic	Rely <u>only</u> on current SGW provider (Xia, Xib proprietary interface)	Yes BBIFF in UPF and LMISF are defined for 5G, interfaces between SGW to LMISF might change
S4 : IMS Passive	IMS	Medium	Yes CDRs could be generated by the probe	High Receive duplicated S8 data including IMS signalling and media traffic for all users	Appropriate tapping points to mirror S8 traffic	Yes (Aggregated) N9 link can be used instead of S8

Table 3: Comparison between the 4 LI Implementation Scenarios

[Next section \(VoLTE/Roaming Testing\) >](#)

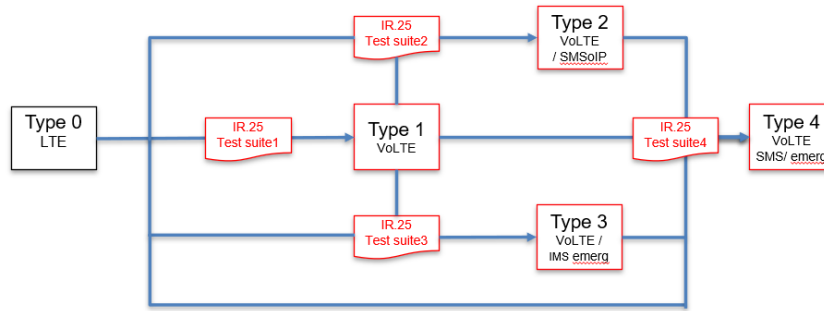

Figure 15: Home VoLTE Evolution – N/W Types and Test Suites

The cited test suites in figure 15 are defined as:

- Test suite1 – VoLTE, SMSoNAS, CSFB Emergency
- Test suite2 – VoLTE, SMSoIP, CSFB Emergency
- Test suite3 – VoLTE, SMSoNAS, IMS Emergency
- Test suite4 – VoLTE, SMSoIP, IMS Emergency

If 2 N/Ws wish to test S8HR VoLTE Roaming, then the test suite to be run is dependent on the “types” of the respective roaming partners as indicated Table 4.

NW A (outbound) \ B (inbound)	Type1	Type2	Type3	Type4
Type1 (VoLTE)	Testsuite1	Testsuite1	Testsuite1 / 3	Testsuite1 / 3
Type2 (VoLTE + SMSoIP)	Testsuite2	Testsuite2	Testsuite2 / 4	Testsuite2 / 4
Type3 (VoLTE + IMS Emerg)	Testsuite1	Testsuite1	Testsuite3	Testsuite3
Type4 (VoLTE + SMSoIP + IMS Emerg)	Testsuite2	Testsuite2	Testsuite4	Testsuite4

Table 4: S8HR Test Suite Combinations

Alternately, a decision tree (as shown in figure 16) can be used for a VoLTE network (i.e B in the table above) to choose the test suite applicable for the inbound roamer.

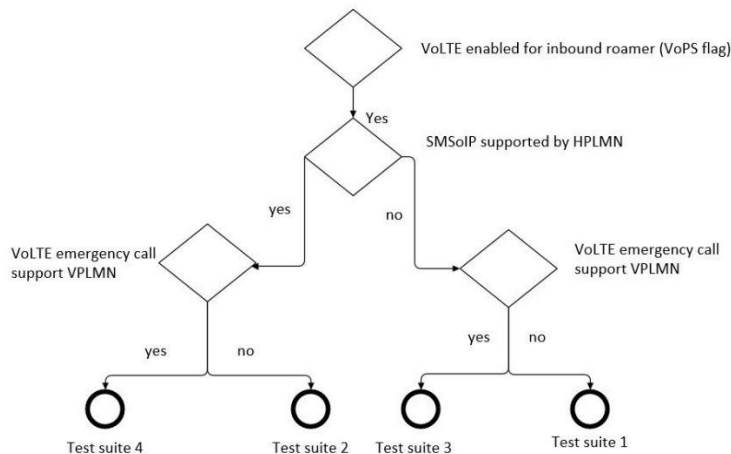

Figure 16: Decision tree to choose test suite for inbound roamer

F.3 Device Testing

A key issue is to reduce the variations across the TS.32 IMS configuration parameters and create a limited number of service profiles so that the device test costs, efforts and delay can be dramatically reduced. NG GERI defined six service related profiles to fully test the device functionally for both non-roaming and roaming cases. The profiles are as follows:

- 2 x Voice over LTE profiles,
- 2 x Voice & SMS over LTE profiles,
- 2 x Voice & SMS over WiFi profiles.

The six service profiles are defined in the embedded spreadsheet below:



Service Profiles
v3.xlsx

The differences between the profiles are as follows:

- Between the two voice profiles:
 - URI derivation,
 - Reliable 18X,
 - Home/Geo-Local Numbers,
 - Voice only / Voice & Video,
 - Codec options
- Between the Voice and Voice & SMS profiles:
 - Enabling SMS
- Between the VoLTE and VoWiFi Profiles
 - PS Voice Preference,
 - HO settings (between WiFi/LTE)

There are a small number of parameters that are related to roaming:

- Policy on local numbers,
- Media type restriction policy when roaming,
- Allow Handover of IMS PDN connection from WLAN to LTE,
- RCS VoLTE single Registration

Therefore a device can be tested for the non-roaming case :

- generically against all of the test suites in annex F.2 for each of the six service profiles to prove generic device functionality and not targeted to a particular network
 - this is applicable for an Open Market Device (OMD)
- against a single Network using the preferred IMS configuration settings of the MNO (which typically do not match any of the six device service profiles) and the appropriate test suite for the “type” of network.

- this is applicable for an Operator Channel Device.

Turning toward roaming, a device must be tested for all 6 service profiles and all combinations of network “type” between the roaming partners as shown in Table 5 below.

NW A (outbound)	B (inbound)	Type1	Type2	Type3	Type4
Device from Type1 (VoLTE)		Testsuite1	Testsuite1	Testsuite1/3	Testsuite1/3
Device from Type2 (VoLTE + SMSolP)		Testsuite2	Testsuite2	Testsuite2/4	Testsuite2/4
Device from Type3 (VoLTE + IMS Emerg)		Testsuite1	Testsuite1	Testsuite3	Testsuite3
Device from Type4 (VoLTE+SMSolP+IMS Emerg)		Testsuite2	Testsuite2	Testsuite4	Testsuite4

Table 5: Decision tree to choose test suite for inbound roamer

F.4 Test Cases

The test cases are defined in GSMA PRD IR.25 [9] section 2.

F.5 Sharing of Test Results

In order to break down the overall testing overhead, it is proposed that the test results be uploaded to a common database and made available to be shared with other interested parties for the common good and to avoid duplication of effort.

F.6 Testing Summary

The testing proposal can be summarised via the following 5 points:

- Only S8HR VoLTE roaming architecture is considered (i.e no LBO option).
- Break down VoLTE test to cover both non roaming vs. roaming tests as well as network test vs. device test
 - non roaming test performed prior roaming test,
 - network test performed prior to device test.
 - use standard tests in all cases.
- focus on testing the three services of voice, SMS and emergency for all VoLTE migration stages.
- Identify four migration types of VoLTE networks for the non-roaming test, implying a 4x4 roaming matrix test between the different network types.
- test the six generic device service profiles. A VoLTE device must support all six profiles and be tested against all six profiles. Networks would be encouraged to align with one of the 6 profiles but are free to define their own N/W specific settings. It is also possible to test a device against a specific network using the preferred settings of that network.
 - Promote commonality of settings between MNOs, in particular within a country or region, to minimise differences and required testing.

In order to realise such testing there would be a need to set up a distributed framework of testing locations who would co-operate as needed and share test results for the common good. Within this framework, look to minimise the shipping of devices and ship SIMs instead. The sharing of test results enables MNOs to identify tested devices and OEMs to identify proven networks. This sharing would create a “snowballing effect” to make the overall task more practical / manageable. Last but not least, no testing is possible if OEMs persist with disabling IMS on the device for “untested networks”. The ability of an OEM to check if a given network has been tested would enable IMS to be enabled for such tested networks.

[Next section \(IR.21 Information related to VoLTE Roaming\) >](#)

Annex G IR.21 Information related to VoLTE Roaming

G.1 VoLTE Roaming Information

VoLTE Roaming architectures supported as VPMN

S8HR	[Yes/No]
------	----------

VoLTE Roaming architectures supported as HPMN

S8HR	[Yes/No]
------	----------

Mobility and Voice Continuity

SRVCC technology supported as VPMN	eSRVCC (3GPP rel. 11 and above) Basic SRVCC (3GPP rel. 10 and before) Not supported
------------------------------------	---

SRVCC technology supported as HPMN	eSRVCC (3GPP rel. 11 and above) Basic SRVCC (3GPP rel. 10 and before) Not supported
------------------------------------	---

Roaming Interconnection (LBO scenarios)

IMS Realm(s)/domain name(s) used for Roaming purpose ³	ims.mnc<MNC>.mcc<MCC>.3gppnetwork.org 3GPP 29.003 §13.2
---	--

S8HR Roaming constraints

Emergency calls

VPLMN technology Strategy for EC	IMS	
	CS Fallback	

List of Local Emergency Numbers in use at the VPMN	Number	Service

Lawful Interception / Data retention

Does VPMN require encryption deactivation by HPMN for IMS procedures	Yes/No
--	--------

³ IMS Realm(s)/Domain Names are in the form of ims.mnc<MNC>.mcc<MCC>.3gppnetwork.org, as specified by 3GPP 29.003 §13.2

EPS QoS to be enforced

Maximum QoS profile supported for "ims" well known APN	<EPS QoS profile> name described in section 20 (LTE Roaming Information) and dedicated to "ims" APN.
--	--

G.2 LTE Roaming Information (part1)

SMS ITW

SMS Delivery mechanism

SMS over IP	[Yes/No]
SMS over NAS	[Yes/No]

Voice ITW

IMS/CSFB/other

IMS/CSFB/other	
----------------	--

G.3 LTE Roaming Information (part2)

List of LTE QOS profiles

Profile name				
QCI ⁴				
ARP Priority Level ⁵				
ARP Pre-emption vulnerability ⁶				
ARP Pre-emption capability ⁷				
Maximum Bit Rate Uplink ⁸				
Maximum Bit Rate Downlink ⁹				
Guaranteed bit rate uplink ¹⁰				
Guaranteed bit rate downlink ¹¹				

4 Mandatory

5 Mandatory

6 Mandatory for Guaranteed Bit Rate EPS bearers. Not applicable for non-GBR ones

7 Mandatory for Guaranteed Bit Rate EPS bearers. Not applicable for non-GBR ones

8 Mandatory for Guaranteed Bit Rate EPS bearers. Not applicable for non-GBR ones

9 Mandatory for Guaranteed Bit Rate EPS bearers. Not applicable for non-GBR ones

10 Mandatory for Guaranteed Bit Rate EPS bearers. Not applicable for non-GBR ones

11 Mandatory for Guaranteed Bit Rate EPS bearers. Not applicable for non-GBR ones

G.4 LPWA Roaming Information

LTE-M Services supported as HPMN	
Power Saving Mode / PSM	[Yes/No]
Extended Discontinuous Reception / eDRX	[Yes/No]
Connected Mode Mobility / CMM	[Yes/No]
Coverage Enhancement Mode A / CE	[Yes/No]
Coverage Enhancement Mode B / CE	[Yes/No]
SMS	[Yes/No]
VoLTE over LTE-M	[Yes/No]
LTE-M Services supported as VPMN	
Power Saving Mode/PSM	[Yes/No]
Extended Discontinuous Reception / eDRX	[Yes/No]
Connected Mode Mobility / CMM	[Yes/No]
Coverage Enhancement Mode A / CE	[Yes/No]
Coverage Enhancement Mode B / CE	[Yes/No]
SMS	[Yes/No]
VoLTE over LTE-M	[Yes/No]
NB-IoT Services supported as HPMN	
Power Saving Mode / PSM	[Yes/No]
Extended Discontinuous Reception / eDRX	[Yes/No]
Coverage Extension	[Yes/No]
SMS	[Yes/No]
NB-IoT Services supported as VPMN	
Power Saving Mode / PSM	[Yes/No]
Extended Discontinuous Reception / eDRX	[Yes/No]
Coverage Extension	[Yes/No]
SMS	[Yes/No]