



MIoT Test Requirements

Version 1.0

19 December 2016

This is a Non-binding Permanent Reference Document of the GSMA

Security Classification: Non-confidential

Access to and distribution of this document is restricted to the persons permitted by the security classification. This document is confidential to the Association and is subject to copyright protection. This document is to be used only for the purposes for which it has been supplied and information contained in it must not be disclosed or in any other way made available, in whole or in part, to persons other than those permitted under the security classification without the prior written approval of the Association.

Copyright Notice

Copyright © 2017 GSM Association

Disclaimer

The GSM Association ("Association") makes no representation, warranty or undertaking (express or implied) with respect to and does not accept any responsibility for, and hereby disclaims liability for the accuracy or completeness or timeliness of the information contained in this document. The information contained in this document may be subject to change without prior notice.

Antitrust Notice

The information contain herein is in full compliance with the GSM Association's antitrust compliance policy.

Table of Contents

1. Introduction	4
1.1 Overview	4
1.2 Scope	4
1.3 High Level Requirements	4
1.4 Definitions	5
1.5 Abbreviations	7
1.6 References	9
2 Basic Operation	10
2.1 Cell selection	10
2.1.1 General overview:	10
2.1.2 Conformance requirements	10
2.2 Registration (attach/detach)	10
2.2.1 General overview:	10
2.2.2 Conformance requirements	11
2.3 Device capabilities	12
2.3.1 General overview:	12
2.3.2 Conformance requirements	12
2.4 Data Transfer and Throughput	12
2.4.1 General overview:	12
2.4.2 Conformance requirements	13
2.5 Mobility	13
2.5.1 Conformance requirements	14
2.6 Suspend/resume	14
2.6.1 General overview:	14
2.6.2 Conformance requirements	14
3 Enhanced Coverage	15
3.1 Random Access	15
3.1.1 General overview	15
3.1.2 Conformance requirements	15
3.2 Data Transfer	15
3.2.1 General overview:	15
3.2.2 Conformance requirements	16
4 Power	17
4.1 Conformance requirements	17
5 Service Layer (oneM2M)	17
5.1 High Level Requirement	17
5.2 General overview	18
5.3 Conformance requirements	19
6 USIM/eUICC	20
6.1 Conformance requirements	20
7 USIM Toolkit	20
7.1 References	20

7.2	Generic Requirements	20
8	Antenna Performance	21
9	Device management (LwM2M)	21
9.1	General Overview	21
9.2	Conformance requirements	21
Annex A	Document Management	24
A.1	Document History	24
A.2	Other Information	24

1. Introduction

1.1 Overview

The purpose of this document is for establishing test procedures for the verification of LTE CAT-M1, CAT-NB1 and EC-GSM-IoT devices ahead of the official introduction of test cases from RAN5 and validation of official test cases from PTCRB and GCF.

These test requirements may also be used to supplement the RAN5 requirements once test cases are officially available and validated.

It should be noted that the requirements listed within this document are those that are deemed as a priority by the MNOs for accreditation of Mobile IoT (MIoT) devices onto their networks. However, the final subset of requirements to be tested will be the subject of discussion and agreement with the MNO and its MIoT device partners in respect of the various features and functionality that may be available on the respective network infrastructure and MIoT devices being deployed at the time of testing.

This document does not replicate any requirements that are currently defined within the GSMA Device Connection Efficiency (DCE) Guidelines TS.34 [18]. Any requirements with regards to DCE will be agreed between the respective MNO's and their Vendors and is outside the scope of this document.

1.2 Scope

The test requirements are defined to be such that they can be performed in an operators live network environment or controlled operator lab environment against target network infrastructure and should not require system simulators to be able to perform.

These requirements shall be applicable as needed to platforms, modules and devices and will reflect the 3GPP R13 Specifications published in June 2016.

1.3 High Level Requirements

The following items form a high level list of areas of focus for an early adopter validation plan for LTE CAT-M1, CAT-NB1 and EC-GSM-IoT. It should be noted that all 3GPP Mandatory Features should be included in the requirements and in the corresponding test case document TS.40[7].

- Basic operation
 - Cell selection
 - Registration (attach/detach)
 - Device capabilities
 - Data transfer
 - Data Throughput
 - Mobility
 - Suspend/resume
- Enhanced coverage
 - Performance

- Mobility
- Power
 - PSM Operation
 - Test with multiple PSM timer values
 - I-eDRX operation
 - Test with multiple idle eDRX timer values
 - C-eDRX
 - Service Layer (OneM2M)
 - USIM/eUICC OTA
 - USIM Toolkit
 - Antenna Performance
 - Device management (LwM2M)

1.4 Definitions

The key words "SHALL", "SHOULD" and "MAY", within this document are to be interpreted as described in RFC 2119 [19], an abstract of which is included within the table below.

Term	Description
MUST	This word, or the terms "REQUIRED" or "SHALL", mean that the definition is an absolute requirement of the specification.
SHOULD	This word, or the adjective "RECOMMENDED", mean that there may exist valid reasons in particular circumstances to ignore a particular item, but the full implications must be understood and carefully weighed before choosing a different course.
MAY	This word, or the adjective "OPTIONAL", mean that an item is truly optional. One vendor may choose to include the item because a particular marketplace requires it or because the vendor feels that it enhances the product while another vendor may omit the same item. An implementation which does not include a particular option MUST be prepared to interoperate with another implementation which does include the option, though perhaps with reduced functionality. In the same vein an implementation which does include a particular option MUST be prepared to be interoperate with another implementation which does not include the option (except, of course, for the feature the option provides.)

The table below provides the descriptions of all other definitions within the document.

Term	Description
Actor	Physical entity (person, company or organisation) that can assume a Role in the functional architecture. It is possible for an Actor to assume multiple Roles in the same functional architecture.
Connectivity Parameters	A set of data (for example SMSC address) required by the eUICC to open a communication channel (for example SMS, HTTPS) on a dedicated network.
Customer	A paying party, in particular a legally responsible juridical person or entity.

Device	Equipment into which an Embedded UICC and a communication module are inserted during assembly. Examples include Utility meter, car and camera.
Disabled (Profile)	The state of a Profile where all files and applications (for example NAA) present in the Profile are not selectable over the eUICC-Terminal interface.
Embedded UICC (eUICC)	A UICC which is not easily accessible or replaceable, is not intended to be removed or replaced in the Device, and enables the secure changing of Profiles.
Enabled (Profile)	The state of a Profile when its files and/or applications (for example, NAA) are selectable over the UICC-Terminal interface.
eUICC Manufacturer	Supplier of the eUICCs and resident software (for example firmware and operating system).
International Mobile Subscriber Identity	Unique identifier owned and issued by Mobile operators to (U) SIM applications to enable Devices to attach to a network and use services.
MlOT Device	A Mobile IoT (MlOT) Device is a generic term to indicate one of the following 3GPP standard technologies for LPWA: CAT-M1, CAT-NB1 and EC-GSM-IoT.
Mobile Network Operator	An entity providing access capability and communication services to its Customers through a mobile network infrastructure.
3GPP module	A communications module complying to one or more of the 3GPP communication technologies such as 2G, 3G, EC-GSM-IoT, CAT-NB1 or CAT-M1, this includes all necessary eUICC or UICC components. Can also be called User Equipment or UE.
Network Access Application	An application residing on a UICC which provides authorisation to access a network for example a USIM application.
Profile	Combination of a file structure, data and applications to be provisioned onto, or present on, an eUICC and which allows, when enabled, the access to a specific mobile network infrastructure.
Profile Component	A Profile Component is an element of the Profile and may be one of the following: An element of the file system like an MF, EF or DF An Application, including NAA and Security Domain POL1 MNO-SD.
Roles	Roles are representing a logical grouping of functions.
SIM	Subscriber Identity Module; a physical entity that contains keys and ID required to authenticate a user on a mobile network. "SIM" is commonly used to refer to the physical entity that is technically called the UICC (see UICC definition below). This document generally uses "SIM" to refer to the physical entity
Subscriber	An entity (associated with one or more users) that is engaged in a Subscription with a Telecommunication Service Provider. The Subscriber is allowed to subscribe and unsubscribe to services, to register a user or a list of users authorised to use those services, and also to set the limits relative to the use that associated users make of those services.

Subscription	Describes the commercial relationship between the Subscriber and the Telecommunication Service Provider.
Subscription Manager Data Preparation	Role that prepares the Profiles and manages the secure download and installation of these Profiles onto the eUICC.
Subscription Manager Secure Routing	Role that securely performs functions of Platform Management commands and the transport of Profile Management commands.
UICC	Universal Integrated Circuit Card; the physical entity that contains as a minimum the SIM/USIM application
USIM	An application that runs on the UICC and provides authentication functions similar to those provided by the SIM in pre-3G systems
Telecommunication Service Provider	The organization through which the Subscriber obtains PLMN telecommunication services. This is usually the network operator or possibly a separate body.

1.5 Abbreviations

Term	Description
3GPP	3 rd Generation Partnership Project
BGA	Ball Grid Array
CAT-NB1	Category Narrow Band 1
CAT-M1	Category M1
C-DRX	Connected mode DRX
CIoT	Cellular Internet of Things
dB	Decibel
dBm	Decibel-referenced to 1 milliwatt
DCE	Device Connection Efficiency
DFN	Dual Flat No lead package
DRX	Discontinuous Reception
DL	Downlink
E-DRX	Extended DRX
ETSI	European Telecommunications Standards Institute
EC-GSM-IoT	Extended Coverage GSM Internet of Things
EDGE	Enhanced Data Rates for GSM Evolution
eDRX	Extended Discontinuous Receive
EGPRS	Enhanced General packet radio service
eUICC	Embedded Universal Integrated Circuit Card
FDD	Frequency Division Duplexing
GERAN	GSM EDGE Radio Access Network
GPRS	General Packet Radio Service
GMSK	Gaussian minimum shift keying
GSM	Global System for Mobile Communications

Term	Description
GSMA	GSM Association
I-DRX	Idle mode DRX
IoT	Internet of Things
IMEI	International Mobile Station Equipment Identity
IP	Internet Protocol
IPSec	Internet Protocol Security
LoRa	Long Range
LPUC	Low Power Use Case
LPWA	Low Power Wide Area
LTE	Long-Term Evolution
LTE eMTC	Long-Term Evolution Enhanced Machine Type Communications
LTE MTC	Long-Term Evolution Machine Type Communications
M2M	Machine-to-machine
MCL	Maximum Coupling Loss
MFF2	M2M Form Factor 2
MHz	Mega Hertz
MNO	Mobile Network Operator
MS	Mobile Station
MTC	Machine Type Communications
NB-IoT	Narrow Band Internet of Things
OFDMA	Orthogonal Frequency-Division Multiple Access
OTA	Over The Air
PLMN	Public Land Mobile Network
PSM	Power Save Mode
QoS	Quality of Service
RAN	Radio Access Network
RF	Radio Frequency
SC-FDMA	Single-carrier frequency-division multiple access
SDOs	Standards Development Organisations
SIM	Subscriber Identity Module (an application running on a UICC)
SMS	Short Message Service
TCO	Total Cost of Ownership
TDMA	Time division multiple access
TR	Technical Report
UE	User Equipment
UICC	Universal Integrated Circuit Card (sometimes known as the SIM card)
UL	Uplink

Term	Description
USIM	Universal Subscriber Identity Module
UTDOA	Uplink-Time Difference of Arrival
WAN	Wide Area Network
Wi-Fi	Wireless Fidelity
WLCSP	Wafer-level redistribution Chip Scale Package

1.6 References

Requirements shall be based on the exact versions as indicated below. However if the manufacturers use a later release and/or version this should be indicated. The GSMA will take efforts to continually align with other Standards Development Organisations (SDOs) for timely information about release plans.

Ref	Doc Number	Title
1.	ETSI TS 102 671	Smart Cards; Machine to Machine UICC; Physical and logical characteristics
2.	GSMA SGP.02	Remote Provisioning Architecture for Embedded UICC Technical Specification version 3.1 or higher
3.	3GPP TS 31.101	UICC-Terminal interface; Physical and logical characteristics, Release 13 or higher
4.	3GPP TS 31.102	Characteristics of the Universal Subscriber Identity Module (USIM) application characteristics Release 13 or higher
5.	3GPP TS 31.103	Characteristics of the IP Multimedia Services Identity Module (ISIM) application, Release 13 or higher
6.	3GPP TS 31.111	Universal Subscriber Identity Module (USIM) Application Toolkit (USAT), Release 13 or higher
7.	GSMA TS.40	MIoT test cases
8.	OMA-TS-LightweightM2M-V1_0	Lightweight Machine to Machine Technical Specification
9.	oneM2M TS 0001	oneM2M Functional Architecture v2.10.0
10.	oneM2M TS 0004	oneM2M Service Layer Core Protocol v2.7.1
11.	oneM2M TS 0026	oneM2M 3GPP Interworking
12.	oneM2M TS 0017	oneM2M Implementation Conformance Statements
13.	oneM2M TS 0018	oneM2M Test Suite Structure and Test Purposes
14.	oneM2M TS 0019	oneM2M Abstract Test Suite & Implementation eXtra Information for Test

Ref	Doc Number	Title
15.	TS.34.114	User Equipment (UE) / Mobile Station (MS) Over The Air (OTA) antenna performance; Conformance testing
16.	TS.37.544	Universal Terrestrial Radio Access (UTRA) and Evolved UTRA (E-UTRA); User Equipment (UE) Over The Air (OTA) performance; Conformance testing
17.	OTA Test Plan v3.6	Test Plan for Wireless Device Over-the-Air Performance
18.	TS34	IoT Device Connection Efficiency Guidelines, Version 3.0, 30 March 2016
19.	RFC2119	Key words for use in RFCs to Indicate Requirement Levels

2 Basic Operation

This section covers the requirements for basic operation in relation to the CAT-NB1, CAT-M1 and EC-GSM-IoT Device.

2.1 Cell selection

2.1.1 General overview:

- CAT-NB1, CAT-M1 and EC-GSM-IoT Device - shall perform PLMN selection process as defined in 3GPP TS 23.122
- CAT-NB1 and CAT-M1 Device - shall perform measurements for cell selection as defined in 3GPP TS 36.304.
- Cell Selection Criterion for CAT-NB1 and CAT-M1 Device are different as specified in 3GPP TS 36.304. CAT-M1 Device is based on legacy Device - Cell Selection Criterion.
- EC-GSM-IoT Device shall perform measurements and act on Cell Selection Criterion as defined in 3GPP TS 45.008

2.1.2 Conformance requirements

The conformance requirements for Cell Selection are specified in Table 1:

CLP.22_2.1.2_REQ_001	CAT-NB1, CAT-M1 device SHALL follow Cell selection Procedure as defined in 3GPP TS 23.122, TS 36.304 TS 36.300
CLP.22_2.1.2_REQ_002	EC-GSM-IoT device SHALL follow Cell selection Procedure as defined in 3GPP TS 23.122 and TS 45.008

Table 1 Cell Selection Requirements

2.2 Registration (attach/detach)

2.2.1 General overview:

Attach Procedure is relation to CAT-NB1 and CAT-M1 Device – with enabled *CIoT EPS Optimizations* in UE Attach Request. EUTRAN cell supports *CIoT EPS Optimizations* shall broadcast in System Information Block (SIB).

UE Network Capability IE in ATTACH Request include different option of CloT EPS optimizations that can be requested:

- Control Plane CloT EPS Optimization,
- User Plane CloT EPS Optimization,
- EMM-REGISTERED without PDN Connection,
- S1-U data transfer,
- Header compression for control plane CloT EPS optimization

The above CloT EPS optimizations as defined in 3GPP TS 23.401 and 3GPP TS 24.301.

SMS transfer without Combined Attach: The MIoT Device should support SMS transfer without the UE being required to perform a Combined Attach. This feature is only available to UEs that only support CAT-NB1 as defined in section 4.3.5.10 of 3GPP TS 23.401.

The support of control plane CloT EPS optimization is mandatory for the network and for the MIoT Device that supports CAT-NB1 and optional to the other Device Category as defined in section 5.3.15 of 3GPP TS 24.301.

If the network supports one or more CloT EPS optimizations and decides to accept the Attach or Tracking Area Update Request, the Network indicates the supported CloT EPS optimizations to the UE per TAI list when accepting the UE Request.

The UE and the network can then use the accepted CloT EPS Optimisations for user IP, non-IP and SMS data transfer after the Attach or Tracking Area Updating Procedure Completes.

The Detach Procedure is based on legacy LTE procedures.

Test for detach procedure Test can reference to the test scenario already defined in section 9.2.2 of 3GPP TS 36.523-1

Attach and detach procedures in relation to EC-GSM-IoT Device are similar to the procedure for Legacy GPRS Device and rely on TS 24.008.

EC-GSM-IoT Device shall request for a GPRS Only attach as combined attached procedure is not supported.

2.2.2 Conformance requirements

The conformance requirements for Attach/Detach are specified in Table 2

CLP.22_2.2.2_REQ_001	CAT-NB1, CAT-M1 device SHALL follow Attach Procedure as defined in 3GPP TS 23.401, TS 24.301 and TS 36.331
CLP.22_2.2.2_REQ_002	CAT-NB1, CAT-M1 device SHALL follow Detach Procedure as defined in 3GPP TS 23.401, TS 24.301 and TS 36.331
CLP.22_2.2.2_REQ_003	EC-GSM-IoT device SHALL follow Attach Procedure as defined in 3GPP TS 24.008
CLP.22_2.2.2_REQ_004	EC-GSM-IoT device SHALL follow Detach Procedure as defined in 3GPP TS 24.008

Table 2 Attach / Detach Requirements

2.3 Device capabilities

2.3.1 General overview:

Device and Network negotiate Device capabilities using the UE Radio Capability information (in RRC Level) and the UE Core Network Capability information (in NAS Level).

UE Radio Capability Information in relation to CAT-NB1 and CAT-M1 Device:

- CAT-NB1 Device will include only limited E-UTRAN parameter in UE Radio Capability as defined in section 4 of 3GPP TS 36.306
- CAT-M1 will include E-UTRAN parameter, Inter-RAT parameter and Radio Paging Information in UE Radio Capability.

UE Core Network Capability information included:

- **UE Network Capability IE** (mostly for E-UTRAN access related core network parameters) which includes *CIoT EPS optimization* in addition to the legacy UE Network Capability supported in 3GPP Release 12 and 13
- **MS Network Capability IE** (mostly for UTRAN/GERAN access related core network parameters).

CAT-NB1 and CAT-M1 Device will include the UE Network Capability IE or the MS network capability IE or both in the UE Core Network Capability during UE ATTACH REQUEST.

2.3.2 Conformance requirements

The conformance requirement for Device Capabilities is specified in Table 3:

CLP.22_2.3.2_REQ_001	CAT-NB1, CAT-M1 device SHALL follow Device Capabilities Procedure as defined in 3GPP TS 36.331, 3GPP TS 36.306, TS 24.301 and TS 23.401
----------------------	---

Table 3 Device Capabilities Requirements

2.4 Data Transfer and Throughput

2.4.1 General overview:

CAT-NB1 Device performance requirements for the physical channels as specified in section 10 of TS 36.211 (for downlink physical channels and uplink physical channels).

EC-GSM-IoT performance requirements for the physical channels are specified, as for Legacy GPRS Device, in TS 45.001 and TS 45.005.

For Uplink Modulation Schemes:

For CAT-M1 Device, supported modulation schemes are QPSK, 16QAM and 64QAM (64 QAM optional in UE); are based on Legacy LTE Device.

For CAT-NB1 Device, supported modulation schemes are; $\pi/2$ -BPSK and $\pi/4$ -QPSK in single-tone transmission, and QPSK for multi-tone transmission.

For EC-GSM-IoT Device, supported modulation schemes under normal coverage conditions are GMSK and optional 8-PSK.

For Downlink Modulation Schemes

For CAT-M, supported modulation scheme are QPSK, 16QAM, 64 QAM and 256QAM; are based on Legacy LTE Device.

For CAT-NB1, only QPSK is supported.

For EC-GSM-IoT Device, supported modulation schemes under normal coverage conditions are GMSK and optionally 8-PSK.

2.4.2 Conformance requirements

The conformance requirement for Data Transfer and Throughput are specified in Table 4:

CLP.22_2.4.2_REQ_001	CAT-NB1, CAT-M1 device SHALL follow Data Transfer as defined in 3GPP TS 36.211 and 36.213
CLP.22_2.4.2_REQ_002	EC-GSM-IoT device SHALL follow Data Transfer as defined in 3GPP TS 45.001 and TS 45.005
CLP.22_2.4.3_REQ_003	The requirement for the data throughput values is to be agreed between the CAT-NB1 / CAT-M1 Device Vendor and the Mobile Network Operator. This requirement and respective test cases agreed between MNO and Vendors should be viewed as preliminary, and final throughput values for normal coverage mode will be consulted through the RAN 5 process.

Table 4 Data Throughput Requirements

2.5 Mobility

For CAT-M1 Device, mobility will cover two sections such as *Cell Reselection (RRC_Idle Mode)* and *Handover (RRC_Connected Mode)*.

For CAT-NB1 and EC-GSM-IoT Device, mobility covers only Cell Reselection.

Cell Reselection:

CAT-NB1 Device - Idle Mode functionality are specified in Section 4.4 of 3GPP Release 36.304.

CAT-NB1 Device measurement rules for cell re-selection are defined in sub-clause 5.2.4.2 of 3GPP Release 36.304 for Intra-Frequency and Intra-Frequencies.

The Cell Selection when leaving RRC_CONNECTED state for the CAT-NB1 Device in sub-clause 5.2.7a of 3GPP Release 36.30.

CAT-M1 Device - Idle Mode functionality and measurement rules apply based on legacy LTE Device.

EC-GSM-IoT Device measurement for Cell reselection and the associated procedures are defined in TS 45.008 and TS 44.018.

Handover:

Mobility functions including Inter-RAT mobility, handover, measurements reports are not supported for CAT-NB1 and EC-GSM-IoT Devices as defined in section 4.10 of 3GPP TS 36.300.

CAT-M1 measurement rules, Inter-RAT mobility and Handover functionality are based on legacy LTE Device.

2.5.1 Conformance requirements

The conformance requirements for Mobility which included Cell Reselection and Handover are specified in Table 5:

CLP.22_2.5.1_REQ_001	CAT-NB1, CAT-M1 device SHALL follow Cell Reselection Procedure as defined in 3GPP TS 36.304, TS 36.300, and TS 36.331
CLP.22_2.5.1_REQ_002	CAT-M1 device SHALL follow Handover Procedure as defined in 3GPP TS 23.401, TS 36.300, and TS 36.331
CLP.22_2.5.1_REQ_003	EC-GSM-IoT device SHALL follow Cell Reselection Procedure as defined in 3GPP TS 45.008 and TS 44.018

Table 5 Cell Reselection and Handover Requirements

2.6 Suspend/resume

2.6.1 General overview:

CAT-NB1 and CAT-M1 Device shall support the Suspend and Resume Procedure when User Plane Clot EPS Optimization is supported in UE and Network.

UE supporting Clot EPS Optimizations can request the use of User Plane Clot EPS optimizations during an Attach or Tracking Area Updating Procedure.

The user plane Clot EPS optimization enables support for change from (RRC-IDLE/EMM-IDLE mode) to (RRC-CONNECTED/EMM-CONNECTED mode) without the need for using the service request procedure. In this case, UE and Network can use Suspend and Resume Procedure.

2.6.2 Conformance requirements

The conformance requirements for Suspend/Resume are specified in Table 6:

CLP.22_2.6.2_REQ_001	CAT-NB1, CAT-M1 device SHALL follow Suspend Procedure as defined in 3GPP TS 36.300, TS 23.401 and TS 36.331
CLP.22_2.6.2_REQ_002	CAT-NB1, CAT-M1 device SHALL follow Resume Procedure as defined in 3GPP TS 36.300, TS 23.401 and TS 36.331

Table 6 Device Suspend / Resume Requirements

3 Enhanced Coverage

3.1 Random Access

3.1.1 General overview

The CAT-M1 and CAT-NB1 Device - shall perform Random Access process under enhanced coverage as defined in 3GPP TS 36.321.

The EC-GSM-IoT Device – shall perform Random Access process under normal and enhanced coverage as defined in 3GPP TS 44.018 using different mapping for EC-RACH as defined in 3GPP TS 45.002 for enhanced coverage.

3.1.2 Conformance requirements

The conformance requirements for (EC)-RACH/PRACH are specified in Table 7:

CLP.22_3.1.2_REQ_001	<p>The CAT-M1, CAT-NB1 Device SHALL perform Random Access process under enhanced coverage as defined in 3GPP TS 36.321, Clause 5.1</p> <p>Required to test the IoT device is able to be configured with relevant communication retry/failure parameters for eventual fall-back mechanisms</p> <p>The test actions cover at least the following</p> <ul style="list-style-type: none"> • Selecting proper parameters for corresponding enhanced coverage level, e.g. Preamble index, PRACH resources. • Setting proper transmit power for corresponding enhanced coverage level • Setting properly the preamble transmission counter • Monitoring proper size and position for PRACH Response WindowSize for corresponding coverage level <p>Changing coverage level when failed to receive RAR</p>
CLP.22_3.1.2_REQ_002	<p>The EC-GSM-IoT Device SHALL follow Random Access Procedure as defined in 3GPP TS 44.018, clause 3.5.2.1.2a and TS 45.002</p> <p>The test actions cover at least the following for normal coverage:</p> <ul style="list-style-type: none"> • Legacy RACH Access with EC PACKET CHANNEL REQUEST using TS3 • 1 TS EC-RACH mapping method for Access_Timeslots=0 <p>The test actions cover at least the following for enhanced coverage:</p> <ul style="list-style-type: none"> • 1 TS EC-RACH mapping method for Access_Timeslots=0 • 2TS EC-RACH Mapping method if Uplink CC2, CC3 or CC4 and Access_Timeslots=1

Table 7 PRACH Requirements for Enhanced Coverage

3.2 Data Transfer

3.2.1 General overview:

CAT-NB1 Device performance requirements for the physical channels as specified in section 10 of TS 36.211 (for downlink physical channels and uplink physical channels).

CAT-M1 Device performance requirements for the physical channels as specified in section 5 and 6 of TS 36.211 (for uplink physical channels and downlink physical channels).

For CAT-NB1 devices under enhanced coverage, procedures of NPDCCH/NPDSCH/NPUSCH using repetition numbers larger than 1 should be tested.

For CAT-M1 devices, under enhanced coverage, procedures of MPDCCH/PDSCH/PUSCH using repetition numbers larger than 1 should be tested.

EC-GSM-IoT Device performance requirements for the physical channels as specified in TS 45.001 and TS 45.005. Only GMSK MCS1 modulation is supported in case of enhanced coverage, in both Uplink and Downlink. Incremental Redundancy HARQ is used to achieve Higher Layer Repetition

3.2.2 Conformance requirements

The conformance requirements for Data Transfer are specified in Table 8:

CLP.22_3.2.2_REQ_001	<p>The CAT-M1Device SHALL follow Data Transfer as defined in 3GPP TS 36.211 and 36.213</p> <p>Required to test the CAT-M1 device is able to perform properly when configured repetition numbers larger than 1.</p> <p>The test actions cover at least the following</p> <ul style="list-style-type: none"> • Receiving SIB1-BR using the good frame and subframe according to the numbers of transmissions • Transmitting PUSCH and receiving MPDCCH/PDSCH using proper repetition number • Setting proper transmit power for PUSCH • Performing proper HARQ process of PDSCH and PUSCH for corresponding repetition number
CLP.22_3.2.2_REQ_002	<p>The EC-GSM-IoT Device SHALL follow Data Transfer as defined in 3GPP TS 45.001 and TS 45.005</p> <p>Required to test the EC-GSM-IoT device is able to perform properly when Uplink and/or Downlink coverage Class is higher than CC1.</p> <p>The test actions cover at least the following</p> <ul style="list-style-type: none"> - Device to adjust the Uplink and Downlink coverage classes accordingly - Device to Handle the blind physical retransmissions according to its associated coverage class as per TS 45.002 - Device to support IR to achieve long term throughput per timeslot
CLP.22_3.2.2_REQ_003	<p>The CAT-NB1 Device SHALL follow Data Transfer as defined in 3GPP TS 36.211 and 36.213</p> <p>Required to test the CAT-NB1 device is able to perform properly when configured repetition numbers larger than 1.</p> <p>The test actions cover at least the following</p> <ul style="list-style-type: none"> • Transmitting NPUSCH and receiving NPDCCH/NPDSCH using proper repetition number

	<ul style="list-style-type: none"> • Setting proper transmit power for PUSCH • Performing proper HARQ process of PDSCH and PUSCH for corresponding repetition number
--	--

Table 8 Data Transfer Requirements For Enhanced Coverage

4 Power

This chapter addresses requirements for low power consumption related function. This includes PSM, eDRX and Reduced Monitoring (for EC-GSM-IoT Device) requirements.

The list of conformance requirements tested within this section are listed in Table 9 in section 4.1.

4.1 Conformance requirements

CLP.22_4.1_REQ_001	CAT-M1, CAT-NB1 Device SHALL support the Power Saving Mode (PSM) defined in 3GPP TS 23.682, TS 24.301 and TS 24.008
CLP.22_4.1_REQ_002	CAT-M1, CAT-NB1 Device SHALL support the Extended Discontinuous Reception (eDRX) defined in 3GPP TS 24.301, TS 36.321 and TS 36.331
CLP.22_4.1_REQ_003	The MIoT Device SHALL support a reduced current drain during Power Save Mode (No references are available to test against, so it is expected that there will be a significant magnitude of reduction in power consumption using PSM).
CLP.22_4.1_REQ_004	EC-GSM-IoT Device SHALL support Reduced Monitoring as defined in 3GPP TS 45.008
CLP.22_4.1_REQ_005	The MIoT Device SHALL have the capability to configure the PSM requested timers for T3324 and T3412 prior to requesting PSM from the network
CLP.22_4.1_REQ_006	The MIoT Device SHALL accept the value of T3412 returned by the network in the Attach Accept message
CLP.22_4.1_REQ_007	The MIoT Device SHALL be able to be locally woken up while in Power Saving Mode
CLP.22_4.1_REQ_008	CAT-M1, CAT-NB1 Device SHALL support configurable eDRX cycle times
CLP.22_4.1_REQ_009	CAT-M1, CAT-NB1 Device SHALL act on paging notification received during eDRX cycle, upon waking from eDRX cycle

Table 9 Low Power Consumption Requirements

5 Service Layer (oneM2M)

5.1 High Level Requirement

The oneM2M standard provides a transversal approach to the service layer, as part of the simplification needed for the IoT actors. Requirements for the IoT service layer as a whole are provided here below.

The oneM2M service platform can provide the high level functions as explained below, when the MIoT device accesses the oneM2M service platform through a 3GPP network (possibly

including C/IoT functions) and the 3GPP network exposes services to the oneM2M service platform:

- Application and Device Registration/De-registration
- Device Management
- Application Management
- Data Reporting and Delivery
- Group Management
- Communication Management
- Security
- Etc.

Note: The oneM2M device registration is based on the registration of the CSE/AE (oneM2M Common Services Entity / Application Entity) on the device to the oneM2M service layer platform.

5.2 General overview

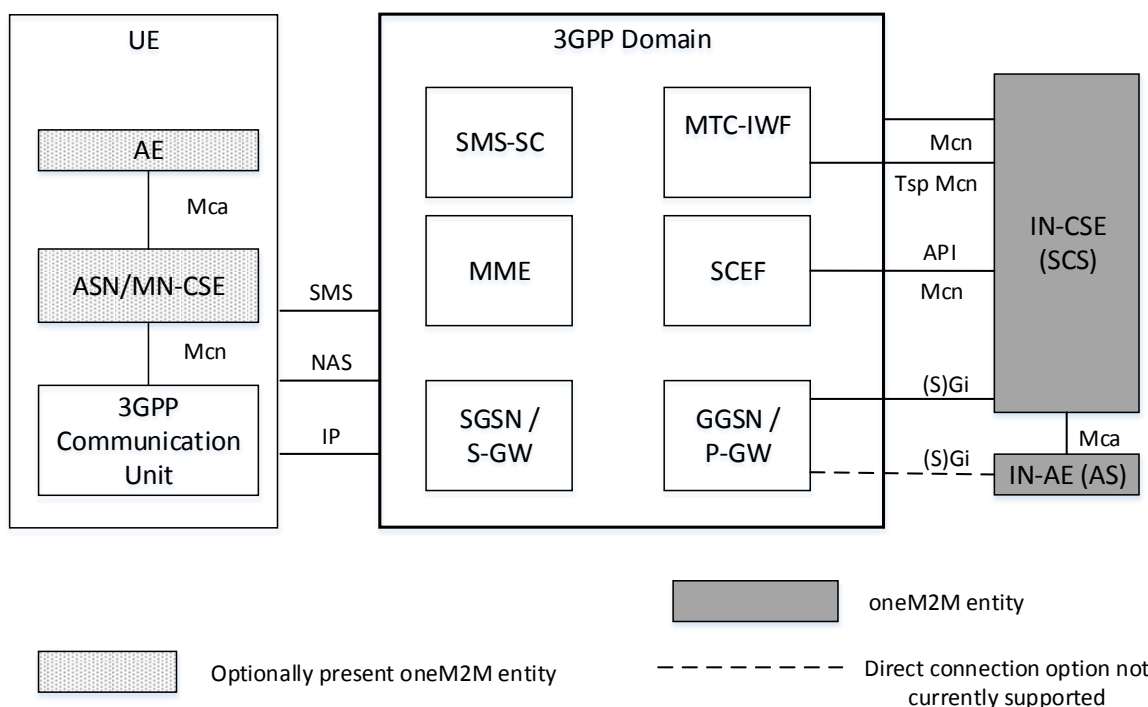

Figure 1: oneM2M Interfaces to the 3GPP Network

The LTE architecture elements are shown in order to illustrate the new bearers. For EC-GSM the user data plane would involve BSS, SGSN and GGSN from where the Gi interface is exposed.

The following terms, present in the above picture, are defined in [9], Section 5.2 and Section 6.1;

- AE: Application Entity:

Application Entity is an entity in the application layer that implements an M2M application service logic. Each application service logic can be resident in a number

of M2M nodes and/or more than once on a single M2M node. Each execution instance of an application service logic is termed an "Application Entity" (AE). Examples of the AEs include an instance of a fleet tracking application, a remote blood sugar monitoring application, a power metering application, or a controlling application.

- CSE: Common Services Entity:

A Common Services Entity represents an instantiation of a set of "common service functions" of the M2M environments. Such service functions are exposed to other entities through the Mca and Mcc reference points. Reference point Mcn is used for accessing underlying Network Service Entities.

- IN: Infrastructure Node:

An IN is a Node that contains one CSE and contains zero or more AEs. There is exactly one IN in the Infrastructure Domain per oneM2M Service Provider. A CSE in an IN may contain CSE functions not applicable to other node types.

- ASN: Application Service Node:

An ASN is a Node that contains one CSE and contains at least one Application Entity (AE). There may be zero or more ASNs in the Field Domain of the oneM2M System.

- ADN: Application Dedicated Node:

An ADN is a Node that contains at least one AE and does not contain a CSE. There may be zero or more ADNs in the Field Domain of the oneM2M System.

- MN: Middle Node:

A MN is a Node that contains one CSE and contains zero or more AEs. There may be zero or more MNs in the Field Domain of the oneM2M System.

According to these definitions, the "MTC Applications" that are hosted on the UE correspond to oneM2M Application Entities (AEs), which may be hosted on a oneM2M Node that can be an ADN, ASN or a MN. For all practical purposes, such a oneM2M Node can be understood as the device, even though the oneM2M standard makes the explicit provision that "As logical objects, Nodes may or may not be mapped to physical objects".

On the network side, the SCS may be mapped to an IN-CSE, and the "MTC-Applications" or ASs that are hosted in an external network may be mapped to IN-AEs.

5.3 Conformance requirements

The list of conformance requirements tested within this section are listed in Table 10.

CLP.22_5.3_REQ_001	The IoT Application (oneM2M AE – Application Entity) can register itself with the CSE (Common Services Entity) of the Service Layer Platform. The test actions cover at least the following: <ul style="list-style-type: none"> • Application Registration/De-registration
--------------------	---

CLP.22_5.3_REQ_002	The IoT Applications (oneM2M AEs) and MIoT device can be managed by the Service Layer Platform. The test actions cover at least the following <ul style="list-style-type: none"> • Device Management • Application Management
CLP.22_5.3_REQ_003	The IoT Applications on the cloud side (IN-AEs) can be configured to get data from and deliver data to the IoT Applications on the MIoT device (ADN-AEs/ASN-AEs) and/or the MIoT device. The test actions cover at least the following <ul style="list-style-type: none"> • Data Configuration • Data Report • Data Delivery

Table 10 Service Layer Requirements

Detailed test requirements for oneM2M are specified in [12] oneM2M Implementation Conformance Statements, as well as in [13] and [14]. These documents should be taken as the primary source of oneM2M-related test specifications.

6 USIM/eUICC

6.1 Conformance requirements

The MIoT device shall support the requirements for (e) UICC and USIM as per Table 11. Generic Requirements

CLP.22_6.1_REQ_001	The MIoT Device SHALL ensure full compliancy with UICC requirements as defined in [3].
CLP.22_6.1_REQ_002	The MIoT Device SHALL ensure full compliancy with M2M-UICC requirements as defined in [1].
CLP.22_6.1_REQ_003	The MIoT Device SHALL ensure full compliancy with eUICC requirements as defined in [2].
CLP.22_6.1_REQ_004	The MIoT Device SHALL ensure full compliancy with USIM and ISIM requirements as defined in [4] and [5].

Table 11 USIM/eUICC Generic Requirements

7 USIM Toolkit

7.1 References

7.2 Generic Requirements

Connected Objects SHALL ensure the full compliancy with the mandatory features of USIM Tool Kit as defined in [6]. In addition to the mandatory features / commands defined in [6], the MIoT Device SHALL support commands as defined in [2] and also the following commands listed in Table 12;

CLP.22_7.2_REQ_001	The MIoT Device SHALL ensure the full compliancy to the USIM Tool Kit as defined in [6]
CLP.22_7.2_REQ_002	The following pro-active commands SHALL be implemented: <ul style="list-style-type: none"> • POLL INTERVAL • REFRESH • SEND SHORT MESSAGE
CLP.22_7.2_REQ_003	The following information SHALL be available: <ul style="list-style-type: none"> • Location Information • IMEI of the terminal • Network Measurement Results • Date, time and time zone • Timing Advance

Table 12 USIM Toolkit Requirements

8 Antenna Performance

It is expected that Antenna Performance in a free space environment within relevant bands and areas will be compliant with 3GPP and CTIA specifications, 3GPP TS.34.114 [15], TS.37.544 [16] and CTIA, OTA Test Plan v 3.6 [17] or later versions of these documents when available.

9 Device management (LwM2M)

9.1 General Overview

The list of conformance requirements tested within this section is listed in Table 13 in section 9.2.

9.2 Conformance requirements

CLP.22_9.2_REQ_001	The MIoT device shall support at least one method of bootstrap defined in the OMA LwM2M specification [8].
CLP.22_9.2_REQ_002	The MIoT device shall be able to identify and register itself with the Application server The test actions cover at least the following <ul style="list-style-type: none"> • Identification and Registration: the device MUST generate an 'end point client name' which is unique for the server (e.g. using IMEI) • Update • Deregistration • While registered the device MUST set 'release assistance indicator' to 00 (binary) to maintain the radio connection (because subsequent transaction messages are expected)

CLP.22_9.2_REQ_003	<p>The MLoT device is able to be configured with relevant communication parameters for normal functioning of the secure communication in the MLoT device</p> <p>The test actions cover at least the following</p> <ul style="list-style-type: none"> • Setting up of parameters which enable communication (like 3GPP, Wi-Fi etc.) • Replace existing parameters which enable communication
CLP.22_9.2_REQ_004	<p>The MLoT device is able to be configured with relevant communication retry/failure parameters for eventual fall-back mechanisms</p> <p>The test actions cover at least the following</p> <ul style="list-style-type: none"> • Setting up (or replace) of retry timers • Setting up (or replace) of sleep/awake timers • The device can be configured with PSM timer (extended T3412), and confirm that this is requested in the subsequent Attach procedure • The device can be configured with Active timer and confirm that this is requested in the subsequent Attach procedure
CLP.22_9.2_REQ_005	<p>The MLoT device supports firmware update over the air using LwM2M.</p> <p>The test actions cover at least the following</p> <ul style="list-style-type: none"> • Upgrade the existing firmware • Handle failures during firmware upgrade process
CLP.22_9.2_REQ_006	<p>The MLoT device can have its configured communication parameters replaced or removed and be reset to factory conditions</p> <p>The test actions cover at least the following</p> <ul style="list-style-type: none"> • To ensure the device is brought to factory default conditions
CLP.22_9.2_REQ_007	<p>The MLoT device can have its security information utilized for secure communication updated over the air.</p> <p>The test actions cover at least the following</p> <ul style="list-style-type: none"> • To test replacement of security information existing for communication
CLP.22_9.2_REQ_008	<p>The MLoT device can report essential health information to the Application Server (e.g. Battery, signal strength)</p> <p>The test actions cover at least the following</p> <ul style="list-style-type: none"> • To test the recovery battery status of the device • To test the right events are triggered during health of the battery is failing or falling below certain conditions • To test the device can be queried for signal strength (e.g., RSRP value, RSSI etc.)
CLP.22_9.2_REQ_009	<p>The MLoT device can report its location to the Application Server.</p> <p>The test actions cover at least the following</p> <ul style="list-style-type: none"> • To test the retrieval of the location information available in the device by the authorized application server • To test support of cell-ID format, or GPS location if supported
CLP.22_9.2_REQ_010	<p>The MLoT device can transfer data to the LwM2M server</p>

	<p>The test actions cover at least the following</p> <ul style="list-style-type: none"> • To test the retrieval of the values possessed by the sensor • To test the retrieval of the communication parameters (like data bytes Rx/Tx, average bytes Rx/Tx, average message size Rx/Tx)
CLP.22_9.2_REQ_011	<p>The MIoT device can report the host provided information details, where the IoT Device resides. E.g. by using the Portfolio Object as defined in OMA-TS-LWM2M_PortfolioObj-V1_0.</p> <p>The test actions cover at least the following</p> <ul style="list-style-type: none"> • To test the retrieval of the following from IoT Device <ul style="list-style-type: none"> ○ Host Device ID where the IoT Device resides ○ Host Device Manufacturer where the IoT Device resides ○ Host Device Model where the IoT Device resides ○ Host Device Software Version where the IoT Device resides
CLP.22_9.2_REQ_012	<p>The MIoT device shall support basic diagnostic capabilities. Test actions to cover at least:</p> <ul style="list-style-type: none"> • The device can be sent a command to do an immediate re-boot • The device can be sent a command to initiate a disconnect/re-attach to the PLMN
CLP.22_9.2_REQ_013	<p>The MIoT device shall support basic observe / notify capabilities. Test actions to cover at least:</p> <ul style="list-style-type: none"> • a device can be requested to provide a periodic notification of Radio signal strength (RSSI).
CLP.22_9.2_REQ_014	<p>The MIoT device shall support basic queue capabilities. Test actions to cover at least:</p> <ul style="list-style-type: none"> • test that device indicates support for queue mode at registration time

Table 13 Device Management (LwM2M) Requirements

Annex A Document Management

A.1 Document History

Version	Date	Brief Description of Change	Approval Authority	Editor / Company
0.1	11 Nov 2016	New PRD (CLP22).	TCJWG/PSMC	David Hills GSMA

A.2 Other Information

Type	Description
Document Owner	MIoT Test and Certification Joint Working Group (TCJWG)
Editor / Company	David Hills, GSMA

It is our intention to provide a quality product for your use. If you find any errors or omissions, please contact us with your comments. You may notify us at prd@gsma.com

Your comments or suggestions & questions are always welcome.