



VoLTE Roaming Testing
Version 2.1
15 May 2018

This is a Non-binding Permanent Reference Document of the GSMA

Security Classification: Non-confidential

Access to and distribution of this document is restricted to the persons permitted by the security classification. This document is confidential to the Association and is subject to copyright protection. This document is to be used only for the purposes for which it has been supplied and information contained in it must not be disclosed or in any other way made available, in whole or in part, to persons other than those permitted under the security classification without the prior written approval of the Association.

Copyright Notice

Copyright © 2018 GSM Association

Disclaimer

The GSM Association (“Association”) makes no representation, warranty or undertaking (express or implied) with respect to and does not accept any responsibility for, and hereby disclaims liability for the accuracy or completeness or timeliness of the information contained in this document. The information contained in this document may be subject to change without prior notice.

Antitrust Notice

The information contain herein is in full compliance with the GSM Association's antitrust compliance policy.

Contents

1	Introduction	3
1.1	Scope of document	3
1.2	Objective of tests	3
1.3	Definition of Terms	5
1.4	Document Cross-References	6
2	Test Cases	6
2.1	Comparison of test cases for LBO and S8HR architecture	7
2.2	BASIC SERVICE TEST CASES	9
2.2.1	IMS Registration of the UE1 (a)	9
2.2.2	UE1 (a) Calls UE2 (a), Both Roamed In VPMN (b)	10
2.2.3	PSTN Telephone in Country Containing PMN (b) Calls UE1 (a), Which Has Roamed to VPMN (b), but the P-CSCF Has Lost The Record For UE1 (a)	11
2.2.4	UE1 (a) Calls to Local Number, UE3 (b)	11
2.2.5	Emergency call	12
2.3	SMS Test Cases	12
2.3.1	Mobile Originated and Terminated Short Message Service (SMS-MO and SMS-MT)	12
3	Equipment Requirements	13
3.1	User Equipment Requirement	13
3.2	Test Equipment Requirement	14
3.2.1	Specific Test Equipment Requirement for LBO Architecture	14
3.2.2	Specific Test Equipment Requirement for S8HR Architecture	14
3.3	Prerequisite of the Network Entities	14
3.3.1	Common Prerequisite of the Visited Network Entities	14
3.3.2	Specific Prerequisite of the Home Network Entities for S8HR Architecture	14
4	Pre-Testing Data Exchange	15
4.1	Testing Contact Information	15
4.2	USIM associated data supplied by PMN(a)	15
Annex A	Appendix	16
Annex B	Document Management	17
	Document History	17
	Other Information	17

1 Introduction

1.1 Scope of document

This document is the specification of IREG end-to-end functional capability tests for all options of VoLTE Roaming (“LBO(Local BreakOut)-HR(Home Network Routing)/VR(Visited Network Routing)” and “S8HR(S8 Home Routed)”) defined at GSMA PRD IR.88 [5], IR.65 [6] and Short Message Service (SMS) over LTE relating to the international roaming of a User Equipment (UE), belonging to a home Public Mobile Network (HPMN) (a), to and within a visited PMN (VPMN) (b).

Whilst it is expected that roaming will be a bilateral activity between two PMNs, please note that this document is written in a unidirectional context. Hence roaming is taking place by a UE (a) to VPMN (b) only. There is no reference to a UE (b) visiting PMN (a).

To complete IREG end-to-end functional capability tests for bilateral roaming, it is necessary to perform the tests in this document twice: the second time the real identities of PMN (a) and PMN (b) are swapped.

IREG Permanent Reference Document (PRD) IR.23 [3] defines the scope and purpose of each stage of testing. GSMA PRD IR.88 [5] defines the technical guidelines for VoLTE Roaming.

This document does not cover:

- Testing of High Speed Packet Access/Long Term Evolution (HSPA/LTE) data roaming
- Diameter Testing
- Exchange of PMN numbering, addressing and routing data [see Stage 3: IREG PRD IR.23 [3]
- Testing of Transferred Account Procedure (TAP), billing applications and any inter-PMN financial statement; [see TADIG PRD [TD.41 \[2\]](#). However the production of a Toll Ticketing file, for use in the TADIG Stage 3 testing is included.
- Definition of operation and maintenance procedures such as contact points for fault reporting and notification of planned works. [see Stage 3: IREG PRD [IR 23 \[3\]](#)

1.2 Objective of tests

The fundamental objective of this testing is to confirm the capability, and sample the quality of both LBO and S8HR VoLTE Roaming services which mobile users will receive when roaming from their HPMN (a) to PMN (b) in LTE. Consequently the tests are restricted to top-level capability testing. There is no provocative or inopportune behaviour testing: this type of testing forms part of the Stage 1 testing [see IREG PRD [IR.23 \[3\]](#).

Because the testing is at a top-priority, its scope includes checking the correct working of user features and any network features required by the HPMN. The scope also includes the confirmation of acceptable quality of transmission, absence of echo and call set-up delay.

The overall objective of the tests is to confirm that the functions and features, which are already known to operate correctly within each separate PMN, will also operate correctly for Inter-PMN roaming.

In addition to the handling of the tests itself the collection/comparison of charging information respective the generation of charging detailed records (CDR) is described.

The specific objectives are to prove that:

- "Registration" can be successfully completed for UE (a) roaming to PMN (b).
- Incoming speech calls to UE (a) can be handled by HPMN(a) and VPMN(b).
 - HPMN (a) successfully routing the call.
 - VPMN (b) connecting the call.
- Outgoing speech calls by UE (a) to the VPMN (b) are handled for:
 - Emergency calls
 - Calls to VPMN (b) country (that is local calls)
- Short Message Service is available between Home Country Service Centre and roamed mobile station.

If either the HPMN or VPMN contain IP Multimedia Subsystem/ Evolved Packet System (IMS/EPS) Network Entities which are supplied by more than one manufacturer, then the test cases should be repeated for each manufacturer.

The actual number of repetitions of the test cases is for bilateral agreement between the HPMN and VPMN. In order to maximize the efficiency of testing, the test cases have been specified so as to minimize the requirement for simultaneous joint activity by both PMN (a) and PMN (b). This concerns mainly the administration of mobile subscriber data in the HSS.

Accordingly, the program of testing forms three distinct components:

- i. HPMN(a) issues pre-programmed USIMs and programmes HSS
- ii. VPMN(b) performs tests
- iii. VPMN(b) and HPMN(a) discuss results

An associated optional objective is to use the Toll Ticketing function of the VPMN to generate a live data file, which is used by the TADIG Stage 3 testing. After transfer to the HPMN via TADIG processes, the HPMN may use the information from the test results to validate the details of the Toll tickets, however this is not part of the GSM Association IREG roaming testing.

1.3 Definition of Terms

Term	Description
APN	Access Point Name
CDR	Charging Detailed Record
CCITT	International Telegraph and Telephone Consultative Committee
CLI	Calling Line Identity
CS	Circuit Switched
CSFB	Circuit-Switched Fallback
DNS	Domain Name System
EPC	Evolved Packet Core
EPS	Evolved Packed System
FQDN	Fully Qualified Domain Name
FTP	File Transfer Protocol
GPRS	Generic Packet Radio Access
GTP	GPRS Tunnelling Protocol
HSS	Home Subscriber Server
HPMN	Home Public Mobile Network
HSPA	High Speed Packet Access
HSS	Home Subscriber Server
IMS	IP Multimedia Subsystem
IMSI	International Mobile Subscriber Identity
IP	Internet Protocol
LTE	Long Term Evolution
MAP	Mobile Application Part
MME	Mobility Management Entity
MSISDN	Mobile Subscriber ISDN Number
P-CSCF	Proxy – Call Session Control Function
PCRF	Policy and Charging Rules Function
PDN	Packet Data Network
PDP	Packet Data Protocol
PGW	PDN Gateway
PIN	Personal Identification Number
PMN	Public Mobile Network
PSTN	Public Switched Telephone Network
PUK	PIN Unblocking Key
SGW	Serving Gateway
SIP	Session Initiation Protocol
SMS	Short Message Service
SMSC	Short Message Service Centre

S-CSCF	Serving – Call Session Control Function
SIP	Session Initiation Protocol
SMS	Short Message Service
SMSC	Short Message Service Centre
TAP	Transferred Account Procedure
TCP	Transmission Control Protocol
UDP	User Datagram Protocol
UE	User Equipment
URI	Uniform Resource Identifier
USIM	Universal Subscriber Identity Module
VLR	Visitor Location Register
VMSC	Visited Mobile Switching Centre
VPMN	Visited Public Mobile Network

1.4 Document Cross-References

Ref	Document Number	Title
1	3GPP TR 21.905	Vocabulary for 3GPP Specifications
2	GSMA PRD TD.41	Testing the Transferred Account Procedure (TAP)
3	GSMA PRD IR.23	Organisation of GSM International Roaming Tests
4	GSMA PRD IR.92	IMS Profile for Voice and SMS
5	GSMA PRD IR.88	LTE and EPC Roaming Guidelines
6	GSMA PRD IR.65	IMS Roaming and Interworking Guidelines
7	GSMA PRD IR.67	DNS/ENUM Guidelines for Service Providers
8	3GPP TS 23.228	IP Multimedia Subsystem (IMS); Stage 2
9	GSMA PRD TD.50	TAP Test Cases(TTC) for VoLTE Roaming Testing
10	GSMA PRD BA.27	Charging Principles

2 Test Cases

The structure for testing international voice roaming and SMS interworking in LTE are recommended to be divided in three groups:

1. Basic Service (Registration, Voice and Emergency Call)
2. Short Message Service (Point to point)

The description for test cases of international voice roaming and SMS over LTE includes both architectures of LBO and S8HR.

Supplementary Services provided for customers in HPMN (a) are independent from VPMN (b) in the both architectures.

2.1 Comparison of test cases for LBO and S8HR architecture

A high level architecture diagram of LBO and S8HR VoLTE Roaming Architecture is represented in Figure 2.1.1 and 2.1.2 respectively. PDN-GW (P-GW) and Proxy - Call Session Control Function (P-CSCF) are located in VPMN(b) in case of LBO architecture whereas they are located in HPMN(a) in case of S8HR architecture.

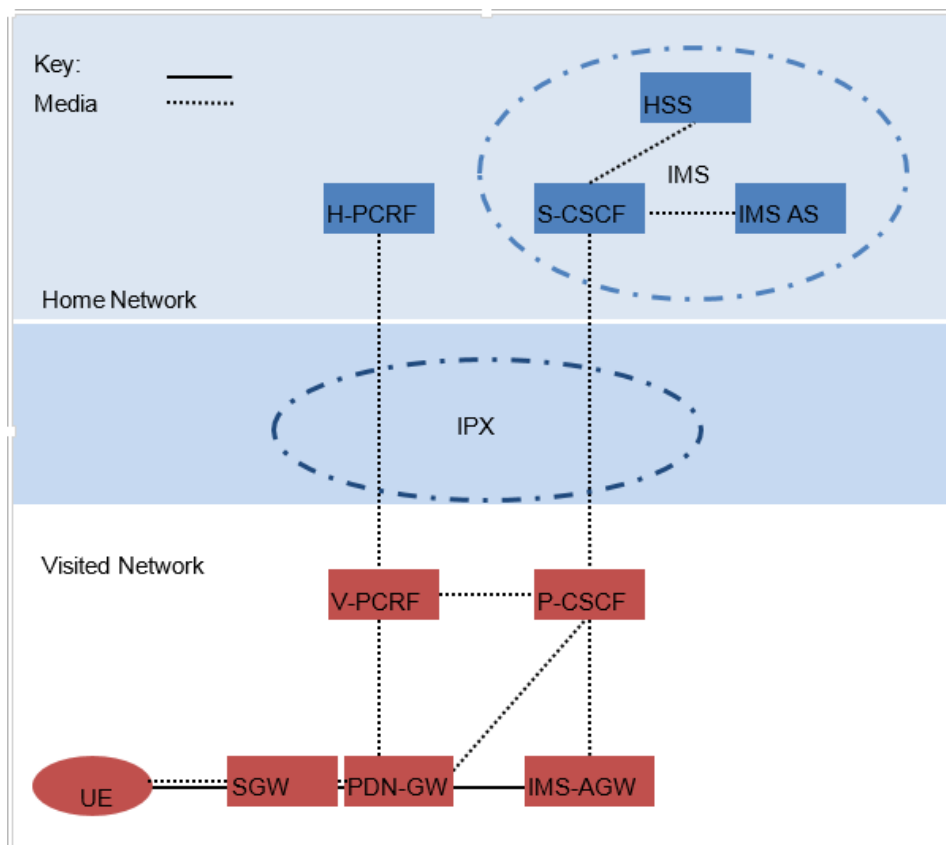

Figure 2.1.1: LBO VoLTE Roaming Architecture

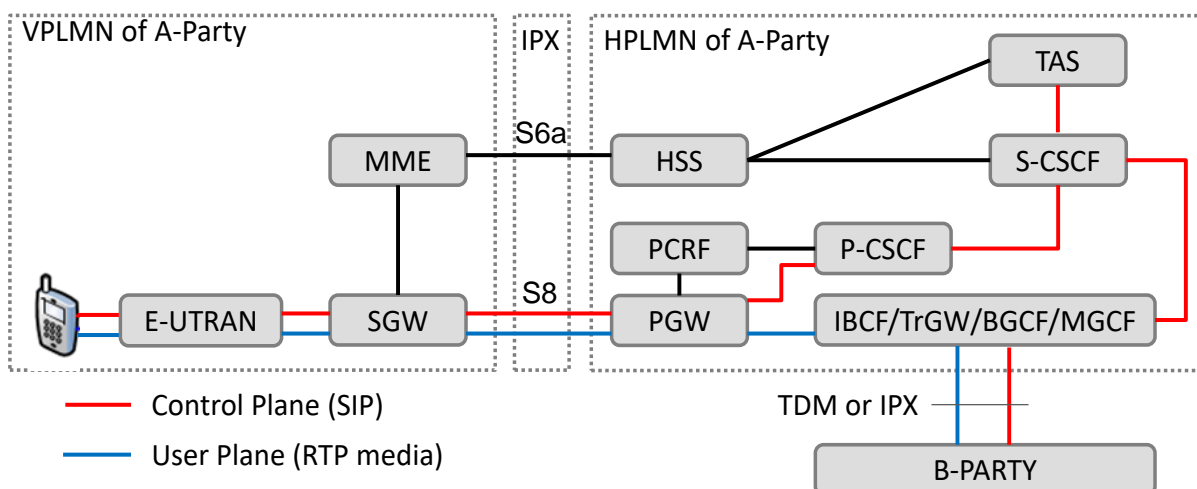

Figure 2.1.2: S8HR VoLTE Roaming Architecture

It is anticipated that it may be necessary to monitor both signalling messages and voice calls on any of the Network Entity interfaces shown in the diagrams. However this is not a firm requirement for this test specification.

The results of the test cases shall be recorded in Annex A: Appendix.

The test cases for each architecture is described in Table 2.1.

Table 2.1: Comparison of VoLTE Roaming Test cases for each Architecture

Section	Test Cases	LBO-HR	LBO-VR	S8HR
2.2.1	IMS Registration of the UE1 (a)	X	X	X
2.2.2	UE1 (a) Calls UE2 (a), Both Roamed In VPMN (b)	X	X	X
2.2.3	PSTN Telephone in Country Containing PMN (b) Calls UE1 (a), Which Has Roamed to VPMN (b), but the P-CSCF Has Lost The Record For UE1 (a)	X	X	
2.2.4	UE1 (a) Calls to a local number, UE3 (b)	X	X	X
2.2.5	Emergency call (CSFB/IMS)	X	X	X
2.3.1	Mobile Originated and Terminated Short Message Service (SMS-MO and SMS-MT)	X	X	X

GSMA PRD BA.27 [10] defines the charging principles for VoLTE Roaming and SMSoIP. [See section 2, 3, 10, 11 and 15 of BA.27 [10]. The outline is described as below.

VoLTE Roaming Charging Principles

S8HR

- Where charging by IMS APN, voice and SIP signalling will not be differentiated and both charged by data volume.
- Where charging by QCI, voice is charged by differentiated QCI (QCI=1) and SIP signalling by QCI5, both can be charged by data volume. This allows differentiated charging between voice and signalling. [See section 11.6 of BA.27 [10]]

LBO-HR & LBO-VR

- Charging principles are similar to those defined for CS voice calls. [See section 2, 3, 11.6 of BA.27 [10]]
- Separate charges may apply for mobile originated vs. mobile terminated voice services as is the custom with CS services. Bearer traffic associated with voice service is not to be included in data usage.
- Signalling traffic (SIP and Diameter signalling) is to not to be included in data usage charges, and as indicated in section 10 of BA.27, will be subject to bilateral IOT.

SMSoIP Charging Principles

S8HR

- Where charging by IMS APN, SMS and SIP signalling will not be differentiated and both charged by data volume.
- Where charging by QCI, SMS and SIP signalling by QCI5, both can be charged by data volume.

LBO-HR & LBO-VR

- SMS traffic over IMS is to be charged as per section 15 of BA.27 [10]. Separate charges may apply for mobile originated vs. mobile terminated SMS as is the custom with CS services. Bearer traffic associated with SMS service is not to be included in data usage.

2.2 BASIC SERVICE TEST CASES

It should be noted that no supplementary services are active during the test cases which are described in Section 2.2.

2.2.1 IMS Registration of the UE1 (a)

2.2.1.1 Preconditions

2.2.1.1.1 Common Preconditions for the both architectures

- UE1 (a) contains Universal Subscriber Identity Module (USIM) of HPMN (a).
- HSS record contains basic and supplementary service information.
- No valid EMM contexts are established for UE1 (a).
- No valid PDN connection is established in the UE1 (a).
- One EPS bearer context subscription record exists in HSS (a) where UE1(a) has a subscription for IMS APN.

When enabling IMS voice roaming for a subscriber, the following subscription settings must be taken into account for the IMS well-known APN:

- Barring on "All Packet Oriented Services" is not active
- The P-CSCF internal database does not have the home network contact information.

2.2.1.1.2 Specific Preconditions for LBO Architecture

- The HPMN must configure "VPMN Address Allowed" parameter as "ALLOWED (1)" for the IMS "well known" APN.

2.2.1.1.3 Specific Preconditions for S8HR Architecture

- The "VPMN Address Allowed" parameter in the HSS (a) must not be present or must be set to "NOTALLOWED (0)".

2.2.1.2 Action

2.2.1.2.1 Common Action for the both architectures

- Power-up UE1 (a).

2.2.1.2.2 Specific Action for LBO architecture

- Perform initial registration through a P-CSCF in VPMN (b).

Check P-CSCF to see 200 OK message from S-CSCF; otherwise check record route of the 200 OK in the UE.

2.2.1.2.3 Specific Action for S8HR architecture

- Perform initial registration through a P-CSCF in HPMN (a).
- Check EMM contexts in UE1 (a) and MME (b) for the IMSI/GUTI /MSISDN of UE1 (a).

2.2.1.3 Expected Result

2.2.1.3.1 Common Expected Result

- PDN Connection (i.e. Default Bearer) for IMS APN is successfully established.
- IMS registration is successfully completed.
- Check SIP Bearer is correctly created using QCI=5.
- Successful result if 200 OK arrives at the P-CSCF.

2.2.1.4 Comments

This test case confirms operation of registration through the P-CSCF. It checks the support of the relevant Session Initiation Protocol (SIP) operations.

2.2.2 UE1 (a) Calls UE2 (a), Both Roamed In VPMN (b)

2.2.2.1 Precondition

UE1 (a) and UE2 (a) have attached successfully and establish PDN connection for IMS APN in VPMN (b).

- UE1 (a) and UE2 (a) have succeeded in IMS Registration to HPMN(a).

2.2.2.2 Actions

- UE1 (a) establishes call to UE2 (a).
- Call answered and held for one minute.
- Quality assessed

2.2.2.3 Expected Result

- Successful result if call is established in 30 seconds, and call is stable in unanswered and answered phases, and there is no perceptible echo to both users, and call remains in intelligible/high quality conversation phase for one minute.
- Check Voice media Bearer is correctly created using QCI=1 for mobile originating and terminating calls respectively.

2.2.2.4 Comments

This test case confirms Mobile Originated and Mobile Terminated call procedures for roamers. It checks the ability to establish international call between the two PMNs using roaming numbers.

2.2.3 PSTN Telephone in Country Containing PMN (b) Calls UE1 (a), Which Has Roamed to VPMN (b), but the P-CSCF Has Lost The Record For UE1 (a)

This test case is not applicable to S8HR architecture.

2.2.3.1 Precondition

UE1 (a) does not have a record in P-CSCF (b) but S-CSCF (a) indicates that UE1 (a) is register through P-CSCF (b).

2.2.3.2 Actions

- PSTN telephone (b2) calls UE1 (a).
- If call is successfully established, then maintain answered call for one minute. Assess quality.
- If call attempt returns "System Failure" message, then make UE1 (a) perform a location update, and repeat this test case.

2.2.3.3 Expected Result

Successful result if either first call-attempt is established or "System Failure" message is returned within 30 seconds. In addition the answered call, whether establish on the first attempt or after the location update, has no perceptible echo to either user, and that an acceptable quality connection can be maintained. See CCITT Rec P.84 Annex D for instructions on use of Quality Scales. This test will also confirm the correct delivery of CLI information (or lack thereof) in a roaming scenario.

2.2.4 UE1 (a) Calls to Local Number, UE3 (b)

2.2.4.1 Precondition

- UE1 (a) is attached to VPMN (b) and has a IMS-APN PDN connectivity.
- UE3 (b) is attached to VPMN (b).

2.2.4.2 Action

- UE1 (a) calls UE3 (b)
- Call answered and held for one minute
- Quality assessed

2.2.4.3 Expected Result

Successful result if call is established in 30 seconds, and call is stable in unanswered and answered phases, and there is no perceptible echo to both users, and call remains in intelligible/high quality conversation phase for one minute. See CCITT Rec P.84 Annex D for instructions on use of Quality Scales. This test will also confirm the correct delivery of Calling Line Identity (CLI) information (or lack thereof) or equivalent parameter in SIP message in a roaming scenario.

2.2.4.4 Comments

This test case confirms that the “Local Number Translation” procedure of IMS entities in HPMN that must support the handling of numbers in non-international format to route the call, as specified in 3GPP TS23.228 [7] and in GSMA PRD IR.65 [3].

2.2.5 Emergency call

2.2.5.1 Preconditions

- UE2 (a) contains USIM of HPMN (a).
- A barring of all outgoing calls is active on UE2 (a).

2.2.5.2 Actions

Power-up UE2 (a) and perform an emergency call to:

- 112 and 911.
- A PSAP number of the visited Country.

2.2.5.3 Expected Result

Successful result if call is established with the Emergency response centre of the visited country.

2.2.5.4 Comments

This test checks the possibility to make an emergency both in the case of UE Detectable Emergency Session and in the case of non UE detectable Emergency Session. With both architectures, the following Emergency Calls options may be possible, depending on the capability of UE, HPMN and VPMN:

- CSFB Emergency Call
- IMS Emergency Call with Emergency Registration
- IMS Emergency Call without Emergency Registration, i.e. anonymous IMS emergency call

2.3 SMS Test Cases

2.3.1 Mobile Originated and Terminated Short Message Service (SMS-MO and SMS-MT)

2.3.1.1 Precondition

SMS- Mobile Originated / Terminated (MO/MT) Services is provisioned in HSS subscription. UE1 (a) and UE2 (a) are registered in VPMN (b).

- UE1 (a) and UE2 (a) are both SMS over IMS capable.
- UE1 (a) and UE2 (a) are camping on LTE.
- UE1 (a) and UE2 (a) successfully completed IMS Registration.

2.3.1.2 Actions

- Switch on UE1 (a). Switch off UE2 (a).
- Use UE1 (a) to transmit a 160 character Short Message to UE2 (a) via the Home Country SMS - Service Centre with Message Waiting priority selected.
- Switch on UE2 (a).
- Await delivery of Short Message to UE2 (a) and check contents of Short Message with those transmitted.

2.3.1.3 Expected Result

Successful result if Short Message is correctly delivered within two (2) minutes of switching UE2 (a) on.

2.3.1.4 Comments

This test case confirms correct operation of SMS - Mobile Originated / Terminated Services including "Message Waiting" and "Note UE Present" procedures.

3 Equipment Requirements

3.1 User Equipment Requirement

- UEs are supplied based on the bilateral agreement between HPMN(a) and VPMN (b).
- Two LTE compatible USIMs supplied by HPMN (a). The supply of additional USIMs may be agreed by the HPMN(a) and VPMN(b), typically for the purposes of:
 - Spare cards in case of failure.
 - Allocation from different HSSs if applicable.
- One USIMs supplied by VPMN (b).
- Two PSTN telephones in PSTN (b) for other test cases than S8HR.

It must be possible to specify what types of UEs are supplied for testing between operator agreement (HPMN (a) and VPMN (b)).

It is expected that manual selection will be used to select VPMN (b) when using the USIMs supplied by HPMN (a). To facilitate subsequent automatic selection it is required that bits b6 and b5 of byte 2 of the USIM Service Table (Data-field 38) be set to "1", and the chosen VPMN is in the PMN Selector (Data-field 30).

In order to replicate the service that general roamers will encounter, it is required that any USIM used in the tests must have one access class out of the classes 0-9 defined. No other access class (for example 10 or 11-15) must be defined.

It is recommended that on any new USIM the Location Update Status field is set to "Status not updated" before the tests start (bit b2 set to "0" and bit b1 set to "1", of byte 11 of Data-field 7E).

3.2 Test Equipment Requirement

Clock capable of being used to allow testing personnel to record call start and chargeable start (that is, answer) time of calls to an accuracy of better than five seconds. If possible, the clock must be adjusted to be in alignment with the clock of MME in VPMN (b) which is used for the Toll Ticketing function. Stopwatch capable of measuring perceived chargeable duration of calls to an accuracy of one second. Packet counter can be prepared as appropriate application installed in UE or Network entities.

3.2.1 Specific Test Equipment Requirement for LBO Architecture

The availability of an IP protocol analyser able to show SIP messages is highly advisable, but not strictly necessary for these tests. SIP traces are supposed to be located between P-CSCF and S-CSCF. However it is essential for any analysis of test case failures. Because SIP signalling is encrypted between the UE and the P-CSCF this will be used only on the Mw interface

3.2.2 Specific Test Equipment Requirement for S8HR Architecture

The availability of a S6a, S8, and DNS interface monitoring equipment is highly advisable. HPMN may have monitoring equipment in its IMS entities such as P-CSCF, S-CSCF and TAS. It is not mandatory but may be useful for VPMN to have packet analyser that can extract SIP signalling being exchanged over GTP tunnels. SIP traces are supposed to be located between P-CSCF and S-CSCF/UE. GTP traces are supposed to be located between P-GW and S-GW.

3.3 Prerequisite of the Network Entities

3.3.1 Common Prerequisite of the Visited Network Entities

For the VPMN and HPMN to enable S8HR VoLTE roaming, the following conditions must be fulfilled in EPC and E-UTRAN as specified in IR.88 [5]. Conditions in IMS are not listed. The VPMN must support the following VoLTE capabilities:

- SIP Bearer with QCI=5;
- Voice media bearer with QCI=1;
- if videocall is supported, then Video media bearer with QCI=2 in case HPMN (a) decides to use GBR bearer, or any non-GBR QCI value.
(HPMN and VPMN should agree on another QCI value for videocall if VPMN does not support QCI value of two (2).)
- Indication from MME to the UE "IMS VoPS Supported Indicator = supported"; and
- Indication from MME to the HSS "Homogeneous Support of IMS Voice over PS" based on the conditions specified in 3GPP TS 23.401[1].

3.3.2 Specific Prerequisite of the Home Network Entities for S8HR Architecture

For the VPMN and HPMN to enable S8HR VoLTE roaming, HPMN must also support the following VoLTE capabilities:

- SIP Bearer with QCI=5;
- Voice media bearer with QCI=1; and
- Video media bearer with QCI=2 (or non-GBR QCI).

As ARP settings are exclusively related to the VPMN service prioritization strategy and may change from one VPMN to another, HPMN should agree with VPMN on a right Priority Level (PL) value to set on IMS default bearer and dedicated bearer in order to ensure that its sessions will be handled with the right priority. QoS (QCI, ARP, AMBR) values should be agreed between HPMN and VPMN.

4 Pre-Testing Data Exchange

It is necessary for the two PMNs to have exchanged the pre-testing data defined in this Section prior to the commencement of testing.

4.1 Testing Contact Information

The following test Co-ordination contact information should be exchanged by both PMNs:

- names,
- telephone numbers,
- fax numbers, and
- email address.

4.2 USIM associated data supplied by PMN(a)

The following information as stored in the SIM and/or HSS is required individually for each of the two SIMs.

- PIN, PUK/ (SUPER PIN).
- IMSI
- MSISDN
- Basic Service Subscription Information
- Public User Identities

Annex A Appendix



LBO VoLTE
Roaming Testcases



S8HR VoLTE
Roaming Testcases

Annex B Document Management

Document History

Version	Date	Brief Description of Change	Approval Authority	Editor / Company
1.0	19 Feb 2013	New PRD (IREG CR1001).Approved at PSMC#118	IREG #64 PSMC	Alfonso Della Fera, Telecom Italia
2.0	3 May 2016	CR 1002 added with S8HR description	NG #3	Veronique Verhé, SIGOS GmbH
2.1	15 May 2018	IR.25 CR1003 IREG to TADIG validation with one to one mapping of test cases	NG#7	Veronique Verhé, SIGOS GmbH

Other Information

Type	Description
Document Owner	IREG SIGNAL
Editor / Company	Veronique Verhé, SIGOS GmbH

It is our intention to provide a quality product for your use. If you find any errors or omissions, please contact us with your comments. You may notify us at prd@gsma.com

Your comments or suggestions & questions are always welcome.