



NG.129 IMS Data Channel White Paper

Version 1.2

4 December 2023

Security Classification: Non-Confidential

Access to and distribution of this document is restricted to the persons permitted by the security classification. This document is subject to copyright protection. This document is to be used only for the purposes for which it has been supplied and information contained in it must not be disclosed or in any other way made available, in whole or in part, to persons other than those permitted under the security classification without the prior written approval of the Association.

Copyright Notice

Copyright © 2026 GSM Association

Disclaimer

The GSMA makes no representation, warranty or undertaking (express or implied) with respect to and does not accept any responsibility for, and hereby disclaims liability for the accuracy or completeness or timeliness of the information contained in this document. The information contained in this document may be subject to change without prior notice.

Compliance Notice

The information contain herein is in full compliance with the GSMA Antitrust Compliance Policy.

This Permanent Reference Document is classified by GSMA as an Industry Specification, as such it has been developed and is maintained by GSMA in accordance with the provisions set out GSMA AA.35 - Procedures for Industry Specifications.

Table of Contents

1	Introduction	4
1.1	Overview	4
1.2	Scope	5
1.3	What Can the IMS Data Channel Bring to Communications?	5
1.4	Definition of Terms & Abbreviations	7
1.5	Document Cross-References	9
2	Industry Vision for Data Channel	11
2.1	Opportunity Statement	11
3	Data Channel Technology	11
3.1	Data Channel Concept Origin and Standardization	11
3.2	What Can the IMS Data Channel Bring to a Voice Call and to Real-time Communications in General?	12
3.3	Unique Aspects of Data Channel in 5G	12
4	Data Channel Associated with a Voice Call	13
5	Data Channel not Associated with a Voice Call	13
6	Single and Multiple Data Channels per Session	13
7	Data Channel Ecosystem	14
7.1	Existing 5G and Voice Ecosystems	14
7.2	Data Channel Value Chain	15
7.3	Data Channel Service Provider Value Chain	16
7.4	Desirable Data Channel Ecosystem Characteristics	17
7.5	Data Channel Ecosystem for Consumer Services	17
8	Operator Stories	19
8.1	5G New Calling	19
8.2	Connected Ambulance with Remote Ultrasound Scanning	20
9	Data Channel User Stories – Interactive Calling	22
9.1	Consumer Segment	22
10	Consumer Calling Business and Business Calling Consumer	22
11	Consumer Calling Consumer	23
12	Consumer Calling an IoT device	26
13	Simultaneous Translation	27
14	Pre-call Multimedia Information Presentation	28
15	Interactive Ringback Tone	31
16	Data channel application with enabled Resume from the point you have left off	34
16.1	Enterprise Segment	35
17	Enterprise Caller ID and Intent	35
18	6.2.1 Enterprise Interactive Ringing Service	37
19	6.2.2 Remote Experts	38
20	IMS Data Channel Beyond MMTEL	39
20.1	Opportunity – IMS Data Channel Beyond MMTEL	40
20.2	Potential Use Cases	41

20.3 Future Work	41
21 Conclusions and Recommendations	42
Annex A Data Channel Architecture	44
A.1 Data Channel Protocol Stack	48
A.2 P2P/P2A/A2P Data Channel Architectures	52
Data channel cloud deployment models	53
Person to Person (P2P)	53
Annex B Person-to-Application (P2A)	57
Application-to-Person (A2P)	61
B.1 Roaming	66
HPMN	67
VPMN	68
IPX/Roaming Hub	68
B.2 DC Control API	69
Functionality of DC Control API	71
B.3 Interconnect	71
Annex C National Interconnect	71
International Interconnect	72
C.1 QoS Framework and Data Channel	72
Annex D Device Support of Data Channel	74
D.1 Voice Centric UE	74
Hardware Architecture of Voice Centric UE	75
Software Architecture of Voice Centric UE	76
Data Channel User Interface of Voice Centric UE	77
D.2 Data Centric UE	79
Annex E Relationship with Enriched Calling	80
Annex F Requirements Summary	81
F.1 Network Requirements	81
F.2 Requirements for Voice-centric UE	81
F.3 Security and Privacy	83
F.4 Commercial Principles	85
F.5 Regulatory	85
F.6 Contractual Aspects	85
Annex G Data Channel Application Market Place	86
G.1 The Data Channel App Developers	86
Data Channel Application Exchange	88
G.2 Data Channel Application Rights Trading	88
Data Channel Software Deployment Process	89
G.3 Data Channel Developer Toolchain	90
Data Channel APIs	90
G.4 Data Channel UE Developer Runtime Environment	90
G.5 The Service Capability Exposure	91
G.6 Data Channel Application Packaging, Release and Deployment	91
Data Channel Application Packaging	91

Data Channel Application Deployment by Local or Remote Authorized Parties	93
Data channel application deployment by local or remote users	94
Annex H Application Life-cycle Management	95
Annex I Data Channel Impact Study	96
I.1 Operator Impact Study	96
I.2 Enterprise Impact Study	97
Annex J Standardization Status	98
J.1 3GPP	98
J.2 GSMA	99
J.3 IETF	100
J.4 W3C	100
Annex K Document Management	101
K.1 Document History	101

1 Introduction

1.1 Overview

This document provides an analysis of the IMS data channel as defined in 3GPP TS 26.114 [1]. The main body of the document covers the following:

- a. Section 1 summarizes the document scope and introduces the IMS data channel technology from the perspective of the communication service provider, consumer, enterprise and developer.
- b. Section 2 outlines the IMS data channel technology vision and the industry expectations.
- c. Section 3 describes the IMS data channel technology.
- d. Section 4 describes the IMS data channel ecosystem.
- e. Section 5 provides operator stories, where specific communication service providers describe the data channel use cases which they are validating.
- f. Section 6 describes user stories enabled by the IMS data channel.
- g. Section 7 outlines future IMS data channel developments which go beyond MMTEL.
- h. Section 8 provides the conclusions and industry recommendations.
- i.

The annexes contain a detailed technical analysis of IMS data channel aspects including some developer guidelines:

- j. Annex A describes the IMS data channel technical architecture.
- k. Annex B describes the device specific data channel architecture elements.
- l. Annex C describes the relationship between Enriched Calling and the IMS data channel.
- m. Annex D summarizes the key IMS data channel requirements.
- n. Annex E focuses on developers and the IMS data channel marketplace.
- o. Annex F summarizes the required changes to the network in order to support the IMS data channel.

- p. Annex G provides an outline of the IMS data channel standardisation status.
- q. Annex H contains the document history.

1.2 Scope

The document provides an analysis of the industry vision for the IMS data channel and an overview of the technology. It explores the need to develop an ecosystem to provide the services described in operator stories and the IMS data channel enabled user stories. The document recommends what is required from the industry (e.g. network operators, vendors and device Original Equipment Manufacturers (OEMs)) to launch these new IMS data channel based services for consumer-to-consumer, business-to-consumer and consumer-to-business communication.

1.3 What Can the IMS Data Channel Bring to Communications?

This section describes the value of the IMS data channel from the perspectives of the Communications Service Provider (CSP), the consumer, the enterprise, and the developer. The term “IMS data channel” is used to indicate that it is the data channel as defined in the 3GPP specifications [1].

Value for Communications Service Provider (CSP):

1. The CSP telephony service is used for more than just voice; it delivers on the 5G promise, by enabling new types of 5G voice services.
2. CSPs can sell communication service bundles beyond 5G mobile broadband subscriptions to new verticals. For example, a CSP could offer 5G connectivity along with an IMS identity, and thus provide both a globally routable end-point identifier (MSISDN) and IMS data channel connectivity.
3. Calls become longer and the telephony service is used more often.

Value for consumers:

1. The CSP can add interactive and sharing capabilities to high quality voice which makes phone calls more useful and interesting for the consumer.
2. No need for consumers to pre-install specific apps from Brands. The call screen will load the needed logic automatically.
3. This can be deployed as a global interoperable service but can also be launched with operator specific services or in specific markets.

Value for enterprises:

1. Businesses already receive their voice services through a relationship with an operator. For a CSP to remain relevant, offering the possibility of IMS Data Channel services to accompany voice calls will benefit both businesses and consumers.
2. An easy option for enterprises/verticals to enable remote control of their machines as well as remote support with voice and data with quality of service.

3. Customer and sales support will be more effective. The agent can give better product advice by sharing web content or Augmented Reality (AR) data in a call, so there is less need for calling the user back.
4. Purchase acceptance can be done in the call, bringing an increased sales success rate.
5. In the vertical industry area, more diversified services can be introduced based on real-time communication such as AR interactive calling and AR remote assistance

Value for developers:

1. Easy development and deployment of innovative applications without the need to standardize them.
2. Web ecosystem insertion into the voice ecosystem

1.4 Definition of Terms & Abbreviations

Term	Description
3GPP	3rd Generation Partnership Project
5GS	5G System
A2P	Application-to-Person
AR	Augmented Reality
B2C	Business-to-Consumer
C2B	Consumer-to-Business
CDR	Charging Data Record
CLIP	Calling Line Identification Presentation
CP-SOR	Control Plane-Steering of Roaming
CSP	Communications Service Provider
CSS	Cascading Style Sheets
DCMTSI	Data channel capable MTSI client supporting data channel media as defined in section 6.2.10 of 3GPP TS 26.114
DA2P	Data Channel Application-to-Person
DCS	Data Channel Server
EPS	Evolved Packet System
HPMN	Home Public Mobile Network
HTML	Hypertext Markup Language
IDE	Integrated Development Environment
II-NNI	Inter-IMS NNI
IMS	IP Multimedia Subsystem
IMS data channel	Data channel as defined in 3GPP TS 26.114 [1]
IREG	International Roaming Expert Group
IVR	Interactive Voice Response
LA2P	Legacy Application-to-Person
LTE	Long Term Evolution
MIME	Multipurpose Internet Mail Extensions
MMTel	MultiMedia Telephony
MoU	Memorandum of Understanding
MTSI	Multimedia Telephony Service for IMS
N9HR	N9 Home Routing
NNI	Network-to-Network Interface
NR	New Radio
OEM	Original Equipment Manufacturer
P2A	Person-to-Application
P2DA	Person-to-Data channel enterprise Application

Term	Description
P2LA	Person-to-Legacy enterprise Application
P2P	Person-to-Person
PMIP	Pre-call Multimedia Information Presentation
PRD	Permanent Reference Document
QoS	Quality of Service
S8HR	S8 Home Routing
SDO	Standards Developing Organization
SHAKEN	Signature-based Handling of Asserted information using toKENs.
SIM	Subscriber Identity Module
SoR	Steering of Roaming
STIR	Secure Telephony Identity Revisited
TADIG	Transferred Account Data Interchange Group
VoNR	Voice over New Radio
VPMN	Visited Public Mobile Network
VR	Virtual Reality
UE	User Equipment
WebRTC	Web Real-Time Communication
XR	eXtended Reality

1.5 Document Cross-References

Ref	Document Number	Title
1	3GPP TS 26.114	IP Multimedia Subsystem (IMS); Multimedia Telephony; Media handling and interaction
2	3GPP Release 17 TS 24.229	IP multimedia call control protocol based on Session Initiation Protocol (SIP) and Session Description Protocol (SDP); Stage 3
3	3GPP TS 23.503	Policy and Charging Control Framework for the 5G System
4	IETF RFC 8864	Negotiation Data Channels Using the Session Description Protocol (SDP)
5	IETF RFC 4960	Stream Control Transmission Protocol
6	3GPP Release 16 TS 24.183	IP Multimedia Subsystem (IMS) Customized Ringing Signal (CRS); Protocol specification
7	GSMA PRD RCC.20	Enriched Calling Technical Specification
8	GSMA PRD IR.92	IMS Profile for Voice and SMS
9	GSMA PRD NG.114	IMS Profile for Voice, Video and Messaging over 5GS
10	3GPP TS 29.165	Inter-IMS Network to Network Interface (NNI)
11	3GPP TS 23.501	System architecture for the 5G System (5GS);
12	3GPP TS 32.274	Telecommunication management; Charging management; Short Message Service (SMS) charging
13	3GPP TS 23.228	IP Multimedia Subsystem (IMS); Stage 2
14	IETF RFC 3234	Middleboxes: Taxonomy and Issues
15	3GPP TS 29.513	5G System; Policy and Charging Control signalling flows and QoS parameter mapping; Stage 3
16	3GPP TS 23.502	Procedures for the 5G System (5GS)
17	IETF RFC 2616	Hypertext Transfer Protocol -- HTTP/1.1
18	GSMA PRD IR.94	IMS Profile for Conversational Video Service
19	3GPP TS 23.221	Architectural requirements
20	GSMA PRD BA.40	Roaming Guide v7.4
21	GSMA PRD BA.60	Roaming Hubbing Handbook v2.5
22	GSMA PRD BA.21	Network Extension Principles v3.12
23	GSMA PRD BA.23	Outbound Roaming Solutions Handbook v1.4
24	GSMA PRD IR.73	Steering of Roaming Implementation Guidelines v6.0
25	GSMA PRD IR.65	IMS Roaming, Interconnection and Interworking Guidelines v33.0
26	3GPP TS 22.041	Operator Determined Barring (ODB)
27	3GPP TS 33.127	Security; Lawful Interception (LI) architecture and functions
28	3GPP TS 32.255	Telecommunication management; Charging management; 5G data connectivity domain charging;

Ref	Document Number	Title
29	GSMA PRD IR.25	VoLTE Roaming Testing v5.0
30	GSMA PRD TD.207	Billing and Charging Evolution (BCE) Testing v1.1
31	GSMA PRD BA.27	Charging Principles v48.2
32	GSMA PRD TD.58	TAP3.12 Implementation Handbook v2.12
33	GSMA PRD TD.57	TAP3.12 Format Specification v36.6
34	GSMA PRD NG.113	5GS Roaming Guidelines v3.0
35	3GPP TS 24.607	Originating Identification Presentation (OIP) and Originating Identification Restriction (OIR) using IP Multimedia (IM) Core Network (CN) subsystem; Protocol specification
36	3GPP TS 24.196	Enhanced Calling Name (eCNAM);
37	3GPP TR 22.873	Study on evolution of IMS multimedia telephony service (Release 18)
38	IETF RFC 8261	Datagram Transport Layer Security (DTLS) Encapsulation of SCTP Packets
39	W3C Recommendation WebRTC 1.0	WebRTC 1.0: Real-Time Communication Between Browsers https://www.w3.org/TR/webrtc/
40	3GPP TS 29.214	Policy and Charging Control over Rx reference point
41	3GPP TS 29.514	5G System; Policy Authorization Service; Stage 3
42	3GPP NG.129	5G Data Channel White Paper
43	IETF RFC 8831	WebRTC Data Channels
44	3GPP TS 33.203	3G Security; Access security for IP-based services
45	3GPP TS 33.328	IP Multimedia Subsystem (IMS) media plane security
46	GSMA PRD FS.38	SIP Network Security
47	3GPP TS 29.522	5G System; Network Exposure Function Northbound APIs
48	3GPP TS 33.210	Network Domain Security (NDS); IP network layer security
49	3GPP TS 23.002	Network architecture
50	3GPP TS 38.300	NR; NR and NG-RAN Overall description; Stage-2
51	IETF RFC 6347	Datagram Transport Layer Security Version 1.2

2 Industry Vision for Data Channel

The data channel enables IMS to handle interactions with the information entities populating the whole info sphere, not only the internet or service provider networks. The IMS data channel defined in 3GPP TS 26.114 [1] enhances the interactivity defined as the spectrum of activities, tasks or processes that two people, or a person and a brand, can execute while using a data channel capable Multimedia Telephony Service for IMS (DCMTSI) client.

The value of the IMS data channel is amplified when strict security, performance and QoS requirements apply. IMS platforms supporting both internet connectivity and IMS connectivity allow a new class of services to be built, some of which are described in this document and others are yet to emerge. Most of the services are foreground active, contextual and engaged communications.

2.1 Opportunity Statement

The IMS data channel defined in 3GPP TS 26.114 [1] enhances the ability of IMS to handle interactions between consumers and the world. With data channel functionality IMS can now enhance the interactivity (i.e. ability to act) with the whole info sphere which is populated with informational entities (forms, web pages, games, devices, services). As such it allows the integration of internet connectivity and IMS connectivity. It also provides action-oriented and multi-modal communications. It blends the communications between subjects with the object control. IMS enhanced with the data channel represents a wider concept, which is the internet itself, providing a real time, reliable, secure, and QoS assured platform supporting web programming model in the industry.

The IMS data channel generates the economic value-added in two ways:

- It enables new innovative services including new device types that can be offered to generate the economic benefits (i.e. revenue, loyalty, churn decrease, acquisition).
 - It optimizes the existing business processes and generates savings for the brands.
- In the first case, the communication service provider (CSP) offers new services, for instance screen sharing, and the user could be charged for its usage. In the second case, new services remove friction from the business process and thus improving some operational aspects. For instance, a visual interactive menu makes interactions with a business easier, increasing consumer satisfaction. Both can be monetized through subscriber contracts and specific commercial terms.

3 Data Channel Technology

This section provides the origin and current status of data channel standardization, and describes its unique characteristics.

3.1 Data Channel Concept Origin and Standardization

The IMS data channel uses the data channel media type as defined in 3GPP Release 16 TS 26.114 [1] and can be used in parallel with other media types such as voice and video in the MultiMedia Telephony (MMTel) service. This data channel is highly flexible and can be used to carry any type of information between the User Equipment (UE) and the network or end-to-end between UEs. It is based on the WebRTC data channel protocol stack as specified by the World Wide Web Consortium (W3C) and Internet Engineering Task Force (IETF). It is

adapted to be used in the 3GPP MMTel context by new procedures in 3GPP Release 16 TS 26.114 [1] and through minor extensions to existing call handling procedures in 3GPP Release 17 TS 24.229 [2].

A key benefit of the IMS data channel media that it inherits from WebRTC is that it is not necessary to standardize the format and interpretation of the content carried in the data channel or explicitly implement support for it in the UE before being able to use it. Instead, the logic needed for formatting and packing on the sender side, unpacking and interpretation on the receiver side, and appropriate user interaction on both sides, are all governed by the dynamically downloaded web page and JavaScript code, common to the sender and receiver UEs. This way and when a generic IMS data channel support is implemented in the network and the UEs, a nearly unlimited number of different use cases involving information sharing between UEs and the network can be realized without further standardization or implementation in the UE or the IMS network. A mechanism via the bootstrap channel has been specified in 3GPP Release 16 TS 26.114 [1] to allow an app chosen by one UE to be distributed to both UEs in a call.

3.2 What Can the IMS Data Channel Bring to a Voice Call and to Real-time Communications in General?

Innovation is stifled by the need, up to now, to standardize each new service associated with IMS. With the deployment of an IMS data channel ecosystem that enables using data channel functionality provided by the CSP and in the UE, operators and developers can get new services in the hands of consumers much more quickly, leveraging existing investment and functionality, without the need to standardize each new service.

Today's real-time communication services provide a mechanism to establish a two-way communication between two or more endpoints, including subscriber authentication and security, end-to-end session establishment and facilitates QoS negotiation. The data channel capability takes advantage of this and provides the ability to establish a real-time communication path between two endpoints to exchange any form of data information, so long as the capabilities of both end points are compatible and agreed between them. This communication path can be in addition to voice and video or can be outside a voice session.

The format of the information carried across the data channel is transparent to the network, as long as it can be understood and interpreted by the end points involved in the session.

The IMS data channel ecosystem has a high chance of success because it reuses existing WebRTC standardization.

3.3 Unique Aspects of Data Channel in 5G

The data channel functions in 5G are placed in a new IMS logical entity, called the Data channel server (DCS). The following figure shows the architecture described in 3GPP Release 16 TS 26.114 [1]:

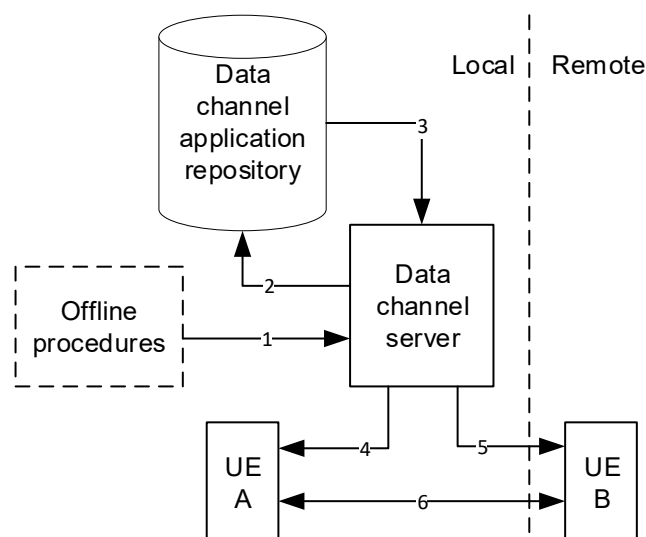

Figure Error! No text of specified style in document.-1 : Architecture from 3GPP TS 26.114 [1]

The numbered arrows in Figure 3.3-1 show how applications are uploaded to the network by the UE or some other authorized party in step 1, and then stored in a repository as per step 2.

4 Data Channel Associated with a Voice Call

In order for a data channel to be used with a voice call, it has to be set up between the two parties in the voice call. A voice call involves the Data channel server to handle the bootstrap data channel media. A bootstrap data channel is used to ensure that each party can receive an application menu (steps 3, 4 and 5) and once a choice is made, procedures ensure they both receive the same application. At that point the end to end data channel is set up (step 6).

5 Data Channel not Associated with a Voice Call

A data channel not associated with a voice call can be described as an MMTel call with an IMS data channel but without voice media. It is allowed by 3GPP TS 26.114 [1] and 3GPP TS 24.229 [2].

One example of what could differ when voice is not present is the use of SIP preconditions: SIP preconditions could be recommended in a call without voice to avoid ghost ringing. In a call with voice and IMS data channel, where the use of SIP preconditions is already mandatory, it could be redundant to use preconditions for the data channel.

6 Single and Multiple Data Channels per Session

As described in section 6.2.10.1 of 3GPP TS 26.114 [1] multiple data channels can be set up per session. The typical example would be one bootstrap data channel for each of the four defined content sources, as described in section 6.2.10.1 of 3GPP TS 26.114 [1], plus any additional application data channels, UE-to-UE or UE-to-network. The overhead to open additional IMS data channels is generally very low and it should be left to the individual

JavaScript to decide on the split of data across multiple data channels, and how many data channels are needed in total by that application. One example could be for an AR session, where different types of AR data are sent in the data channel(s) and handled by the JavaScript in each end.

As stated in section 6.2.10.1 of 3GPP TS 26.114 [1], transport requirements and QoS usage may differ for different data channels, subject to the needs from individual data channel applications. If that is the case and if the network ability to provide different QoS is limited to one per network 5-tuple (source IP, source port, destination IP, destination port, and protocol), data channels with different QoS requirements may have to be split across different IMS data channel media descriptions (SDP m= lines), where each 5-tuple corresponds to a single media description.

7 Data Channel Ecosystem

This section describes the 5G and data channel ecosystems and how they fit together.

7.1 Existing 5G and Voice Ecosystems

The sequence of value creating activities within the 5G industry is referred to as the 5G industry value chain. See Figure 4.1-1. In this paper the starting point is a functional component that computes business logic for Web or telco industries.

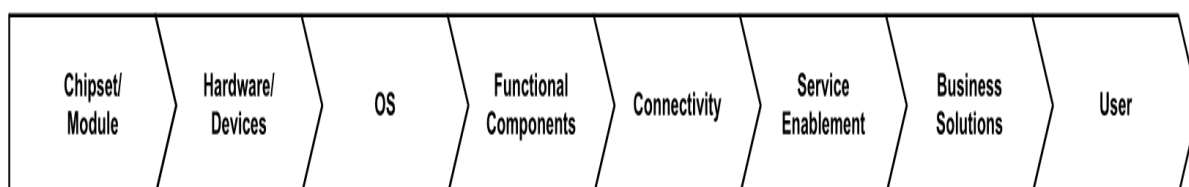

Figure 4.1-1: Telco/5G value chain

This section describes the pre- and post-data channel value chain for the real time and Web services. Figure 4.1-2 shows the existing Web value chain, with the communication service providers being the suppliers of connectivity service, specifically for 5G providing the packet core Internet APN for the internet access. The internet content is served on top of the MBB contract.

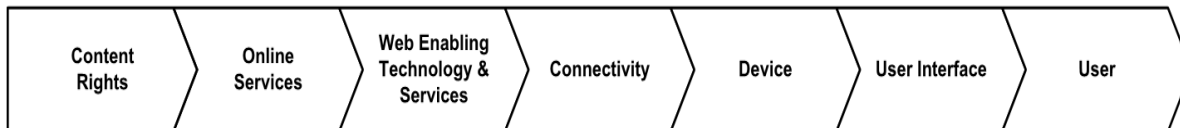

Figure 4.1-2: Web value chain (derived from GSMA 2016 report “The Internet Value Chain”)

Within each of the value generating activities, market segments exist with companies that make part of the whole internet industry.

The real time / voice value chain exists independently of the Web value chain and is shown in Figure 4.1-3.

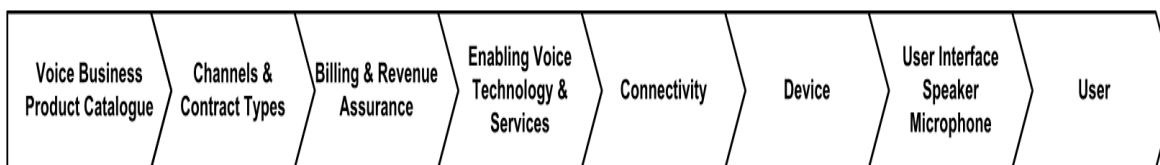

Figure 4.1-3: Voice value chain

The voice services are delivered over IMS APN and use a dedicated IMS infrastructure.

7.2 Data Channel Value Chain

The data channel is an enabling technology for a new real-time business product which combines the voice products with the Web content rights as illustrated.

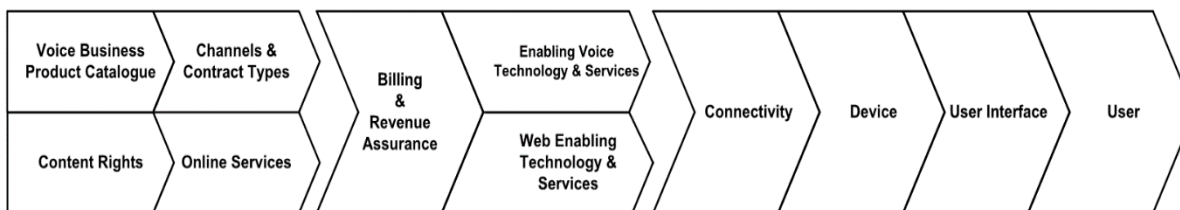

Figure 4.2-1: Data channel value chain

From the business perspective the IMS data channel offers a new content distribution method which service providers can contractually offer at wholesale to internet content providers in parallel to their own content as shown on Figure 4.2-2.

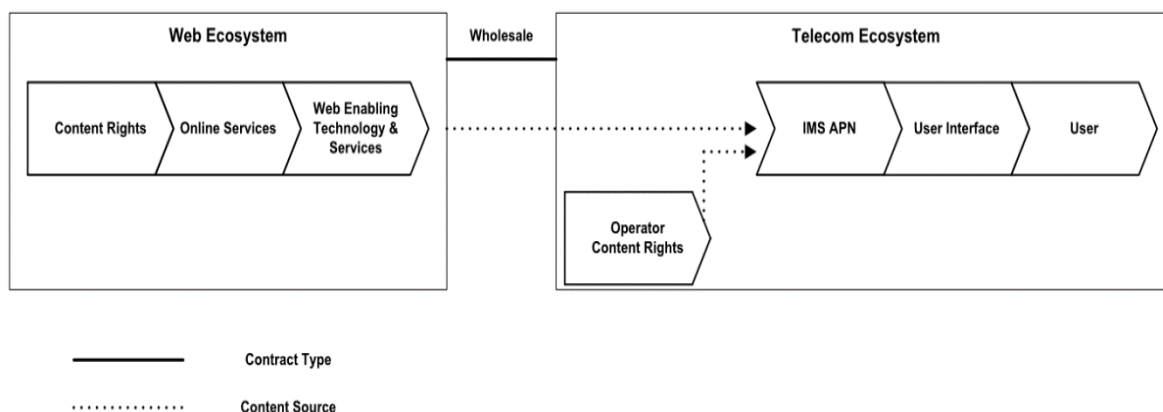

Figure 4.2-2: The data channel industry

Figure 4.2-2 illustrates the business innovation enabled by opening IMS APN to internet content. In this case the new content can be served as part of an MBB contract or as a VoNR addition to voice.

In this context, it should be recognized that there is potential value in allowing individual users to create and use their own data channel content and services in their own calls, without any need to commercially publish that content also for use by others. Such an approach would be enabled by use of well-known and generally available Web development technology, and by making the deployment of such personal content into the ecosystem very easy.

7.3 Data Channel Service Provider Value Chain

This section focuses on the technical aspects of the service provider data channel value chain, which represents the coordination of all activities related to the delivery of data channel service and offering value to the service provider’s customers.

The key value driver of a data channel ecosystem is to provide the right data channel Web application and content to the right receiver at the right time.

The classical service provider value chain has been based on the ownership of all the productive assets and processes used to deliver voice services. With the emergence of the data channel, the classical value chain extends beyond the company that is managing the voice network, and – more importantly – the “application”, or “app”, is delivered only when needed, or just-in-time. The data channel does not require an operator to own the content to be served to its consumers. It only requires that it is available or sourced when needed.

Therefore, by the data channel ecosystem we mean all the industry participants that contribute to the communications service provider data channel value proposition. The data channel ecosystem is shown in Figure 4.3-1 together with the legacy internet content delivery.

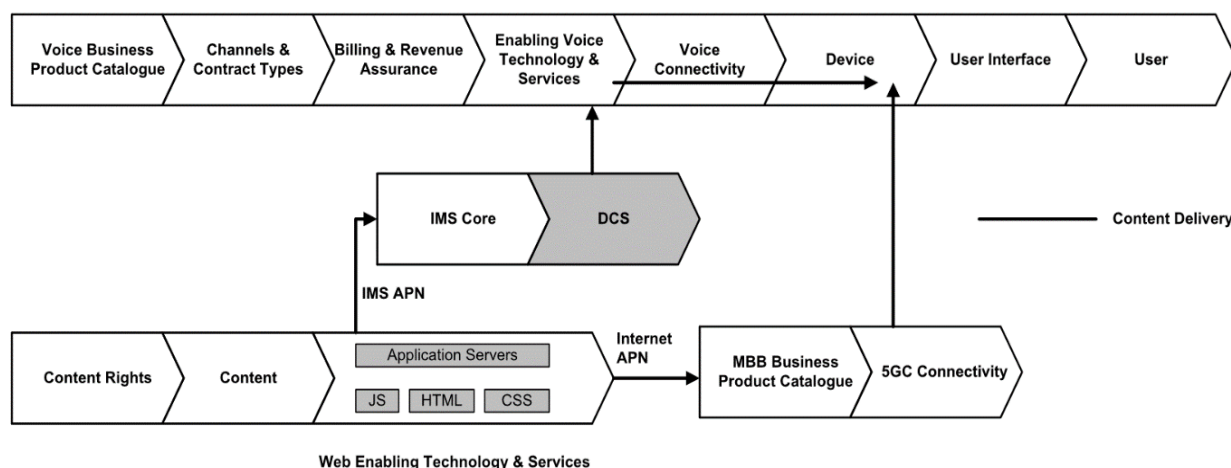

Figure 4.3-1: IMS data channel ecosystem

The IMS data channel ecosystem consists of all the industry participants which enable:

Figure 2Data channel content ownership

Figure 3Data channel content creation

1. Data channel content insertion into IMS, specifically Data Channel Server providers
2. Data channel content delivery

Communications service providers who provide the channel to the user
 Internet **service providers who might own the service platforms

3. Intermediaries allowing data channel terminations
4. Clearing houses between the content owners and serving companies

The data channel ecosystem has only three (3) roles:

5. Content creation
6. Content distribution
7. Digital rights management / billing

The current industry still needs to design the business processes to include the data channel in the overall communications procedure.

7.4 Desirable Data Channel Ecosystem Characteristics

The success of this ecosystem relies on achieving a set of desirable properties:

It must be designed with simplicity.

It must be easy to access the ecosystem.

The content must be easy to reuse in various call contexts.

See Annex E for content creation and developer aspects.

1. It must be sustainable.
2. It should not be predatory.

It must innovate and enable creation of new content.

See Annex E.

3. It should be open and follow Web governance.

4. It must be trustable.
 See Annex E on content development and Annex D.3 Security and Privacy.

7.5 Data Channel Ecosystem for Consumer Services

The figures below show an ecosystem providing applications for Business-to-Consumer (B2C) and for Consumer-to-Consumer (C2C).

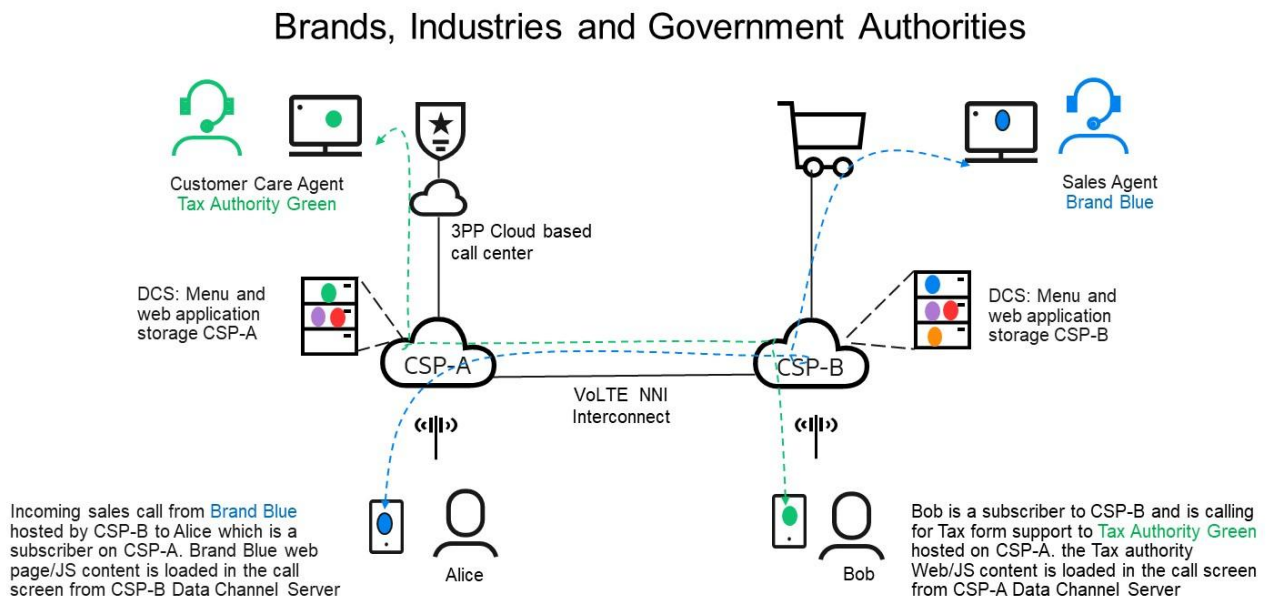

Figure 4.5-1: IMS data channel ecosystem B2C calls

In Figure 4.5-1, the dotted lines show two different B2C calls. In each case they show when the Voice call is established, and when the JavaScript (JS) apps start communicating Person-to-Person (P2P) using the new IMS data channel media set up in the call.

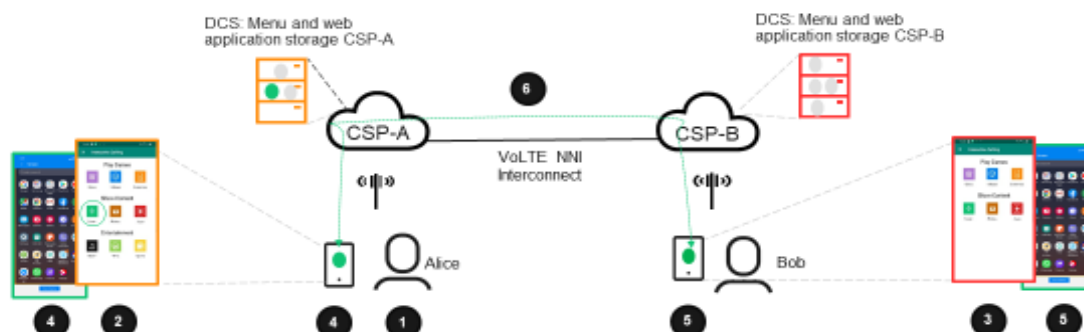

Figure 4.5-2: IMS data channel ecosystem C2C call with Alice calling Bob

The steps involved in Figure 4.5-2 are as follows:

1. Alice calls Bob.
2. Alice's dialer displays an interactive menu from CSP-A Data Channel Server (DCS) received via the bootstrap data channel
3. Bob gets his interactive menu from CSP-B DCS received via Bob's bootstrap data channel
4. They agree to start screen sharing. Alice selects the screen sharing app from her menu and it is loaded from CSP-A DCS in a new browser tab.
5. The screen sharing JavaScript app is also loaded on Bob's phone from CSP-A DCS in a new tab
6. Data channel media is set up between the screen sharing apps and sharing can start

8 Operator Stories

8.1 5G New Calling

China Mobile Communications Corporation (CMCC) is one of the leading telecommunication service providers and the world's largest telecommunication service provider in terms of subscriber numbers. Its businesses primarily consist of mobile voice and data, wireline broadband and other information services.

The real-time communication remains indispensable in 5G as the industry advances past speech and video towards AR/VR, holographic communication and IMS data channel

scenarios. The VoNR supported by 5GC is critical enabler for IMS data channel and factor behind its momentum.

During MWC Shanghai 2021, CMCC and its partner Huawei jointly unveiled the IMS Data Channel based 5G New Calling solution. It can be deployed on the top of VoLTE/VoNR network and provides the HD enhanced voice experience, visual and interactive services. All those are required to meet the requirements of sophisticated and highly developed China 5G market which as of August 2021 is reported 500 million of 5G subscribers.

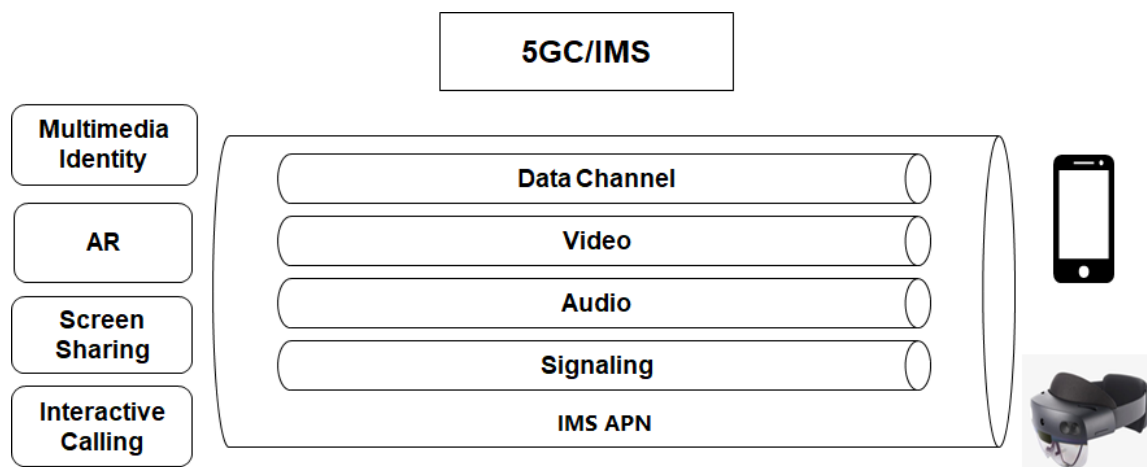

Figure Error! No text of specified style in document.-2 : 5G New calling solution based on IMS data channel architecture.

CMCC and Huawei have made progress of testing the data channel technology in their pilot projects of 5G New Calling. IMS data channel creates a new web based business ecosystem for offering services for C2C and B2C. The Interactive Calling, Screen Sharing, and some other use cases will be further verified by CMCC.

In the near future, 5G New Calling services are expected to become mainstream and prevalent in China, improving both the communication efficiency and user experience in all industry sectors.

8.2 Connected Ambulance with Remote Ultrasound Scanning

BT is one of the world's leading communications services companies, serving the needs of customers in the UK and across the world, where we provide fixed-line services, broadband, mobile and TV products and services as well as networked IT services.

A good example of BT's technology innovation is the Connected Ambulance proof of concept (PoC). This is a fully immersive technology solution over 5G showing how next-generation mobile networks support emergency services. It is a clear example of 5G as an enabler for innovation in healthcare and IMS Data Channel played a key role in demonstrating this innovation.

The objective of this PoC is to enable real-time collaboration between specialists at hospitals or medical centres with paramedics in the field. Figure 5.2-1 shows how 5G and IMS data

channel can be combined with medical expertise to enable remote diagnostics and link field practitioners with surgeons or consultants in real time, allowing them to remotely assess and diagnose a patient, view medical records, vital signs and ultrasounds.

Ericsson, King's College London and Voysys – a media visualisation software company, were BT's research partners for this project. Using basic IMS principles for signalling and negotiating end to end voice and video calling channels, the addition of the IMS data channel in the same session allows for the inclusion of bi-directional data communication using an ultrasound equipment for interaction between the remote paramedic in an ambulance and a specialist in a hospital. The paramedic at the ambulance attends to the patient wearing a haptic glove and holding an ultrasonic probe. The paramedic receives real time feedback from the remote ultrasonic specialist – also wearing a haptic glove and holding an ultrasonic probe - assisting them to move the ultrasonic probe to different areas of the patient to diagnose possible medical problems. In effect, the secure remote connectivity from specialist in a hospital to the paramedic in the ambulance allows the specialist to have virtual hands-on control of the ultrasound machine with the patient. Coupled with the immersive visuals and voice provided by the special 180-degree stereoscopic video camera and headset, the specialist at the hospital can interact directly with the patient and guide the paramedic through the diagnosis.

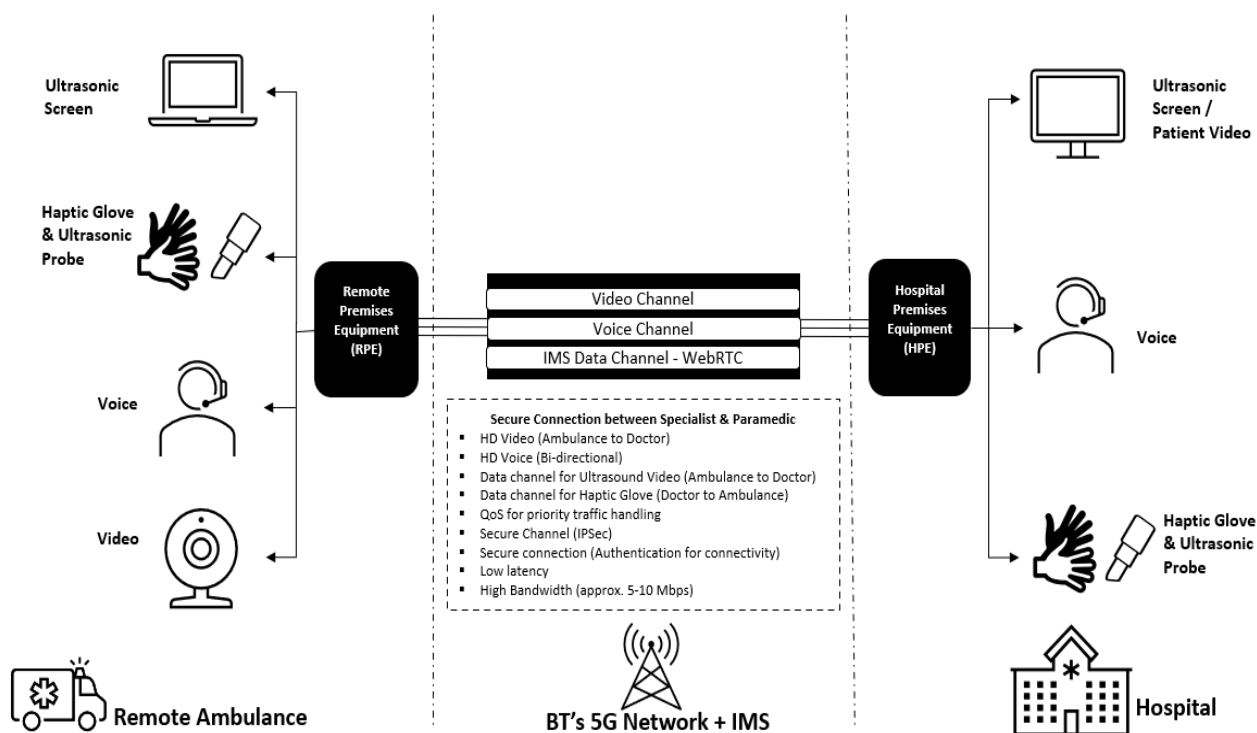

Figure Error! No text of specified style in document.-3 : Setup showing connected ambulance with remote ultrasound scanning using IMS data channel.

This research collaboration on IMS Data Channel offers great value add. Pre-hospital ultrasonic services require highly skilled expertise for diagnosis. By providing remote connectivity, this expertise can be centralized and deployed remotely as required. In this case any expert could connect to any ambulance or point-of-care to support diagnosis. This

PoC demonstrates how 5G can enable real-time services to deliver significant cost savings by reducing the number of patient trips to hospitals, ensuring patients are sent to the right hospital/unit for their condition or accelerating the triage and admission processes once a patient arrives to the hospital. This technology solution can be applied to use cases related to remote interaction such as drone navigation and robotic surgery.

This remote ultrasound concept using IMS data channel has been demonstrated live at Mobile World Congress 2019. Successful trials have also been completed by BT in conjunction with the UK government and NHS Trust and Ambulance Services as part of a multi-city 5G testbed to trial new technologies that can transform healthcare services in the UK. Though the data channel implementation in this PoC was based on the WebRTC data channel protocols (UDP/DTLS/SCTP), an evolution to use other protocols for the IMS data channel will be considered in the future.

9 Data Channel User Stories – Interactive Calling

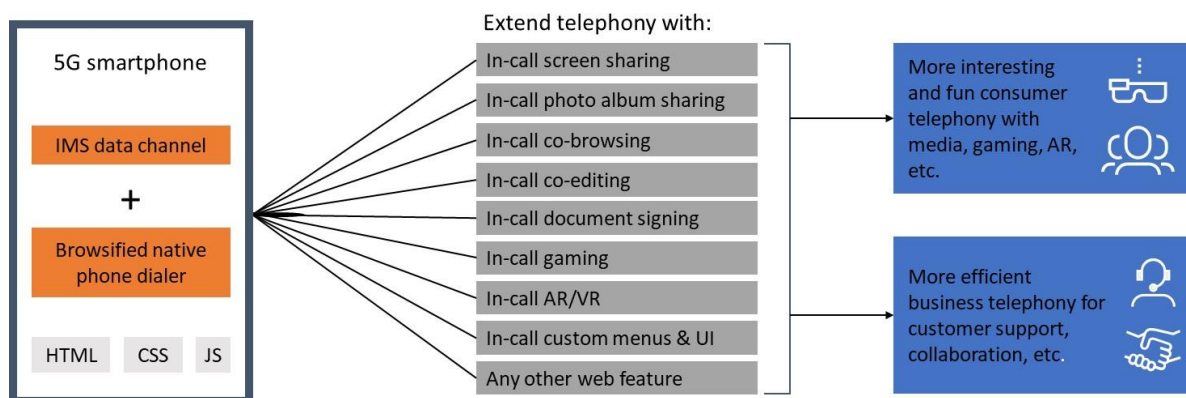

Figure 6-1: Interactive calling on 5G smartphones - Ease of use for consumers and businesses.

Voice calling has existed for almost 150 years now and until today it has been just that, voice calling. Now with 5G we have the possibility to radically change this and open infinite new possibilities for voice calling by making it interactive: during the voice call a user will be able to do more than just talk. They will be able to share their screen or photo album, play games or browse the web with the other party, listen to music or watch videos together, and so on. Voice calling will be more fun and interesting for consumers. It will improve service for business telephony and customer support, where a business can share visual interactive menus and solve issues in a much more interactive way.

9.1 Consumer Segment

10 Consumer Calling Business and Business Calling Consumer

These user stories are considered to be business voice user stories. They cover customer support, sales calls and virtual shopping for example.

10.1.1.1 Interactive Calling for Consumer Calling a Business

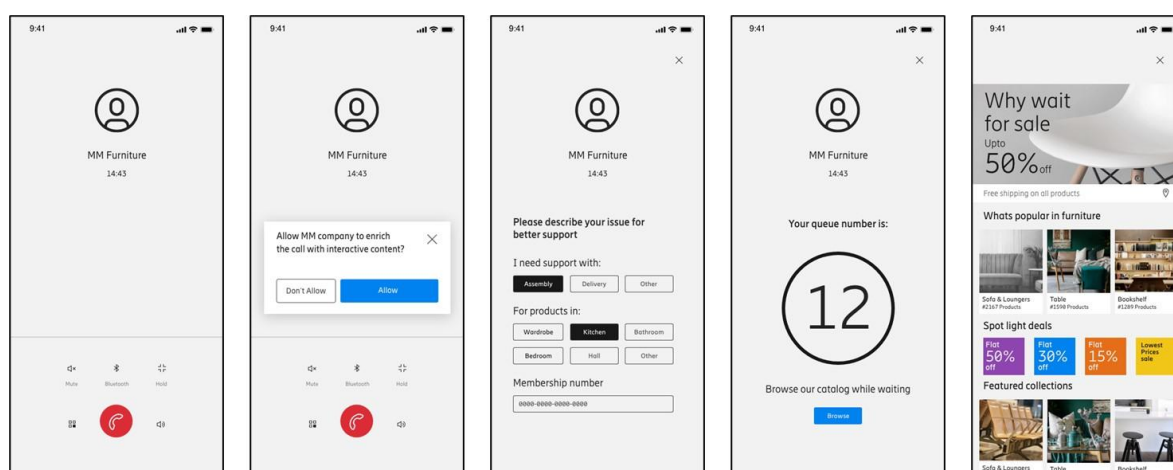

Figure Error! No text of specified style in document.-4: Example of interactive calling: support call to a business.

In this user story, a business enhances an incoming call from a consumer with relevant data shared directly on the call screen, such as a visual interactive menu, information about waiting time to speak to an agent and an offer to browse the company's web site. The use of the data channel provides an interactive experience when calling a business without the need to install an app. The typical consumer business data channel user story develops as follows:

1. The user calls a furniture company for support.
2. The user is prompted in-call, to enrich the call with interactive content (provided by the data channel).
3. A visual interactive menu is provided to the user and the user makes their selections.
4. The user receives information on their place in the call queue.
5. The user browses while waiting to be connected to an agent. With co-browsing, the agent will know what the customer is currently browsing.

Calls to a tax authority or to an insurance company when an accident has happened, are other examples.

Future support centres will have voice robots that you can talk to as a complement to a visual interactive menu. The voice robot can interact with the consumer both via voice and visually on the Interactive call screen.

Another area where a consumer wants to share data can be health care. A consumer calls the home doctor for a regular check-up and can easily share sensor data stored in the smartphone or watch. There is no need to download a specific app in advance which can be cumbersome for elderly people

11 Consumer Calling Consumer

Consumer to consumer user stories involving the data channel enhance the quality of communication between individuals. For example, the data channel facilitates communication such as:

1. Where to meet, sharing positions on a map in the call screen, and
2. Sharing a website to discuss a new movie or consumer goods offer.

11.1.1.1 Screen and Location Sharing

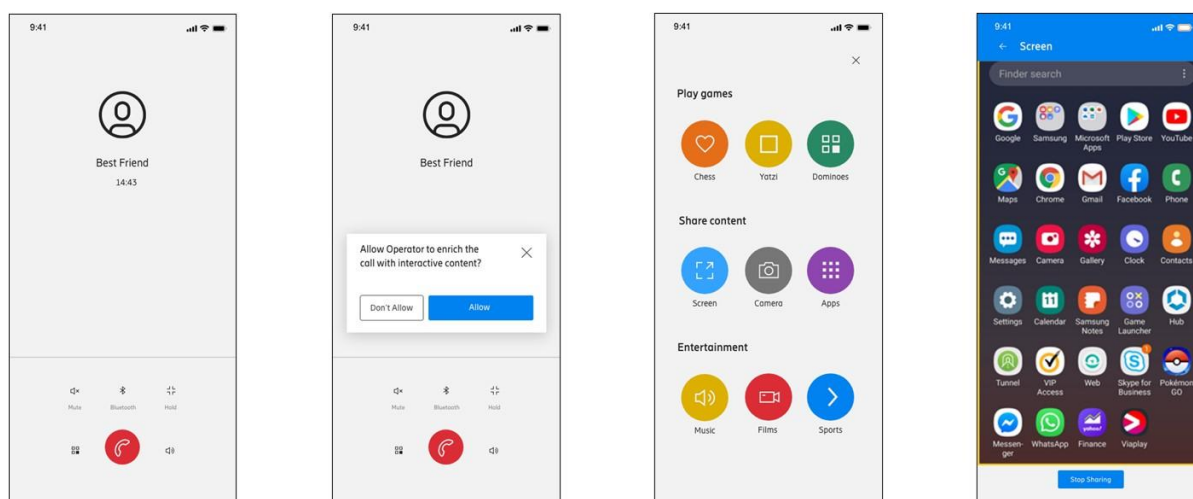

Figure Error! No text of specified style in document.-1: Example of screen sharing from one user to another.

This user story shows screen sharing between two users:

1. The user calls their “best friend”.
2. The user is prompted in-call to enrich the call with interactive content (provided by the data channel).
3. Once a voice session is set up, the user selects a JavaScript app to be loaded on both devices. In this user story, the user chooses “Screen” in Share content.
4. The user shares their screen with “best friend”, and each with their own laser pointer, can point or draw on the screen being shared

11.1.1.2 Social Gaming

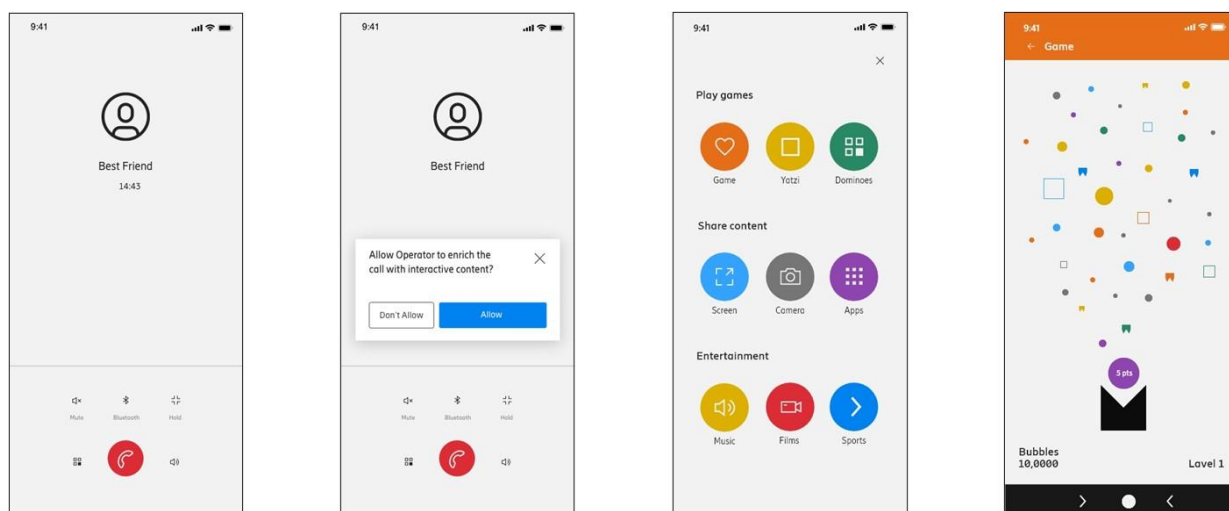

Figure 6.1.2.2-1: Example of users playing a game together.

This user story shows two users playing a game together:

1. The user calls their "best friend".
2. The user is prompted in-call to enrich the call with interactive content (provided by the data channel).
3. Once a voice session is set up, the user selects a JavaScript app to be loaded on both devices. In this user story, under Play games, the user chooses a game.

Other C2C examples of future types of social calls:

1. Share a Quiz game in the screen, AR bowling, Ping pong with AR glasses and using hands to hit the ball;
2. Create and talk, for example children can play with virtual "paper clip dolls";
3. Virtual hug/handshake, new haptic glove accessory.

11.1.1.3 Smart Assistant in the Call

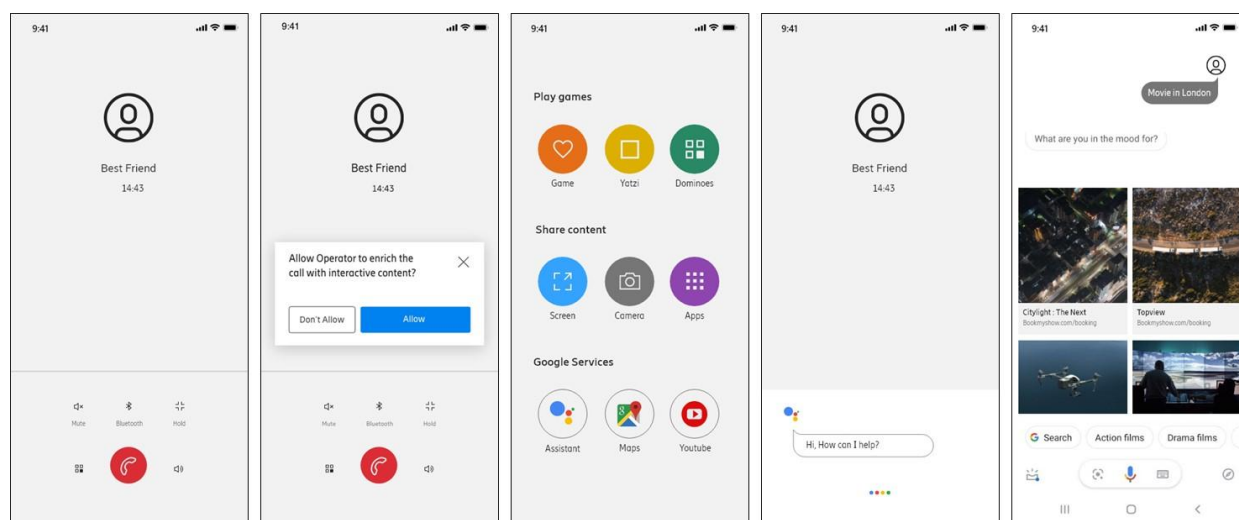

Figure 6.1.2.3-1: Example of screen sharing with in-call smart assistant.

The panels in Figure 6.1.2.3-1 are described here:

1. The user calls their “best friend”.
2. The user is prompted in-call to enrich the call with interactive content (provided by the data channel).
3. The user has access to multiple services in-call including Smart Assistant.
4. The user and “best friend” can interact with Smart Assistant.
5. The user and “best friend” buy movie tickets in London with the help of Smart Assistant.
A translation service could also be a smart assistant user story where the translation in text is visible on the call screen.

11.1.1.4 Extended Reality (XR)

Consumer calls can be augmented with XR data, for example real-time interactive games and AR glasses; AR bowling, Ping pong with AR glasses and using hands to hit the ball

Hologram rendering data can be sent over that data channel.

The steps involved are as follows:

1. The user calls their “best friend”.
2. The user is prompted in-call to enrich the call with interactive content (provided by the data channel).
3. Once a voice session is set up, the user selects a JavaScript app to be loaded on both devices. In this user story, under “Play games”, the user chooses an XR game.
4. The user and “best friend” play the game, with their applications sending and receiving the data required to provide the interactive game.

12 Consumer Calling an IoT device

A consumer may call IoT devices such as 5G-360 cameras, and home assistant robots or appliances. IMS data channel is used for real-time remote control and visual feedback.

13 Simultaneous Translation

Communication Service Providers may offer a specific service for people visiting their networks. The simultaneous translation is a subscription based service which utilizes the IMS data channel technology. A user intending to obtain this service needs to have an IMS data channel capable UE since the translation result will be delivered as a streaming text.

There are two main flavours of simultaneous translation

1. Real-time in-band simultaneous translation directly transforms RTP speech payload between the two languages. It is done with a hard real time constrain and does not require a party to change focus from UE speaker mode to the screen mode as the translation is delivered “to the ear”
2. Semi-real-time out-of-band translation transforms RTP speech payload into the text of the original language and then the translation to the target language is performed on the text. This service is not a hard real time service and there might not be total synchronisation between the speech and the text. It requires change of focus as the translation is delivered “to the eye”

The latter is the focus of the user story and is applicable to the general subscriber but also to specific cases, for instance for hearing impaired.

When the simultaneous translation service is applied then the conversation between parties is processed in a normal fashion but at the same time the speech is relayed between the user being translated and the translation platform. The relay might use 3GPP or IETF mechanisms. The translation platform automatically recognizes the speech, and performs the translation with the result being delivered as the media type text displayed using translator user interface. The service requires to have the focus on the screen therefore the use of headphone or Bluetooth headset is recommended.

When providing the simultaneous translation service, the operator shall guarantee that the translation service shall respect all privacy regulations, including the provisions related to the voice or text trust chain.

13.1.1.1 The User Story

Andrew is an American who travels to China on vacation. Andrew knows very little Chinese and finds it very difficult to understand telephone conversation, so he hopes to use the simultaneous translation service provided by the local operator to assist him in telephone conversations with Chinese people. Andrew has signed a contract with the local operator, received local Subscriber Identity Module (SIM) card and applied for simultaneous translation service, after arriving in China. The service subscription is configured with the default option “Translate Chinese to English”.

The following example illustrates how the simultaneous translation service would be used:

1. Andrew ordered a cab to his hotel from an online ride-hailing platform. But due to traffic jam, the car is late. The cab driver, Chen, decides to call Andrew to inform the traffic jam.
2. Chen uses their smartphone to call Andrew, dialling Andrew’s local phone number.
3. Andrew answers the call from Chen.

4. The operator network offers the interactive calling menu with data channel applications to Andrew's screen. One of the applications is the simultaneous translation service. If the system detects Chen's terminal has the IMS data channel capability, it also pushes the interactive calling menu to Chen's screen.
5. The system informs the calling user (i.e. Chen) that the conversation may be simultaneously translated by the 3rd party platform when requested by the called party. It allows the calling user to reject the simultaneous translation and processing of his speech by the platform.
6. Andrew selects "Translate Chinese to English" from the interactive calling menu.
7. As per Andrew's demand, the system relays the audio speech from the remote side (i.e. from Chen) to the translation platform. The platform translates between the two languages and displays the result as a streaming text on Andrew's UE screen.
8. Chen finds that the remote user cannot speak Chinese, thus selects the default operation - "Translate English to Chinese" from his interactive calling menu.
9. As per Chen's demand, the audio speech from Andrew is translated to text in Chinese. The system displays the text translation result on Chen's screen.

The simultaneous translation service allows Andrew and Chen to understand each other without understanding their respective native languages.

14 Pre-call Multimedia Information Presentation

The traditional Calling Line Identification Presentation (CLIP) feature only provides the calling party number to people who subscribe to the service. It enables only the rudimentary identification of the calling party. While STIR/SHAKEN solves the problem of caller ID authentication and enhances the voice ecosystem trust principles, it still might not provide the sufficient context information for called party to decide whether to accept the call.

The Pre-call Multimedia Information Presentation (PMIP) feature allows users to send the additional call related content during the ringing process. This pre-call information might be static or provided on per-call basis. It can communicate the call intent, provide the enhanced caller identification with the caller's job title, picture, and location. All the information is transmitted over an IMS data channel.

Note: There may be new requirements for the data channel application to store some persistent information in UE or even work offline when the connectivity is lost.

So, the calling party sets the default multimedia information using the call settings menu. The personalized B-party multimedia information would be set using the contacts application and those settings take the precedence over default. All PMIP information is stored in UE.

The content will be delivered using only HyperText Markup Language (HTML) elements with Multipurpose Internet Mail Extensions (MIME) types accepted by all UE. For instance:

1. Text: HTML <body> element can be used to display the text
 - a. **Example:** <body><h1>This is text</h1></body>
2. Image: HTML element is used to embed an image in an HTML page

- b. **Example:** ``
3. Location: CDN can be used to embed maps API into HTML pages
- c. **Example:** `https://developers.google.com/maps/documentation/javascript/adding-a-google-map`

This user story involves the interaction between the customer and the real estate agent who needs to communicate a specific high-end real estate opportunity. Market evidence exists that customers have a preference for enhanced caller identification and want to know the call intent. The user story develops in the following stages:

1. The agent presses and holds one customer's contact on the Contacts screen, then a data channel services settings menu shows up and the agent chooses pre-call multimedia information settings, as shown in Figure 6.1.5-1. Under this menu, the agent inputs the call subject, uploads a picture of his business card. When they tap the select location button, and choose the location of the real estate they are selling on a map, then the location is saved.

Note: The user does not need to upload this information prior to each call or perhaps can only update some parts of the template when new content is to be included as part of PMIP.



Figure Error! No text of specified style in document..5-1: Pre-call multimedia information settings.

2. The agent makes a call to the customer using their smartphone.
3. The customer's smartphone rings, and at the same time a menu of data channel applications is made available on the agent's smartphone.
4. The agent decides to use PMIP service and selects it from the menu of available services. Meanwhile, the multimedia information set for this specific called party is retrieved by the PMIP service when the DCS loads the application. Then three tabs for subject, picture and location are displayed. There are two modes of sending call intent and identification information, all-in-one mode, which means the calling party can send all the information at once, or one-by-one mode when the calling party sends the information individually by sequentially selecting the tabs. It depends on user preference and UI design. In this story, the calling party chooses one-by-one mode.

5. As shown in Figure 6.1.5-2, the agent taps the subject tab to select the content to be send. The call intent appears on his screen. They tap the blue icon to send the call intent to the customer. Then the customer's mobile phone displays the agent's call intent.



The agent's smartphone



The customer's smartphone

Figure Error! No text of specified style in document..5-2 :The real estate agent sends their call intent

6. The agent then chooses to send the business card. The image of the business card shows on the screen. Then again, the agent uses send icon to display the business card to the customer. Then the customer's mobile phone displays the agent's call intent and business card as shown in Figure 6.1.5-3.



The agent's smartphone



The customer's smartphone

Figure Error! No text of specified style in document..5-3: The real estate agent sends their business card

- The customer is not picking up the call, so the agent decides to send the location. Again, the agent taps the blue icon to send the coordinates of the real estate property. Then the location appears on the screen, as shown in Figure 6.1.5-4.

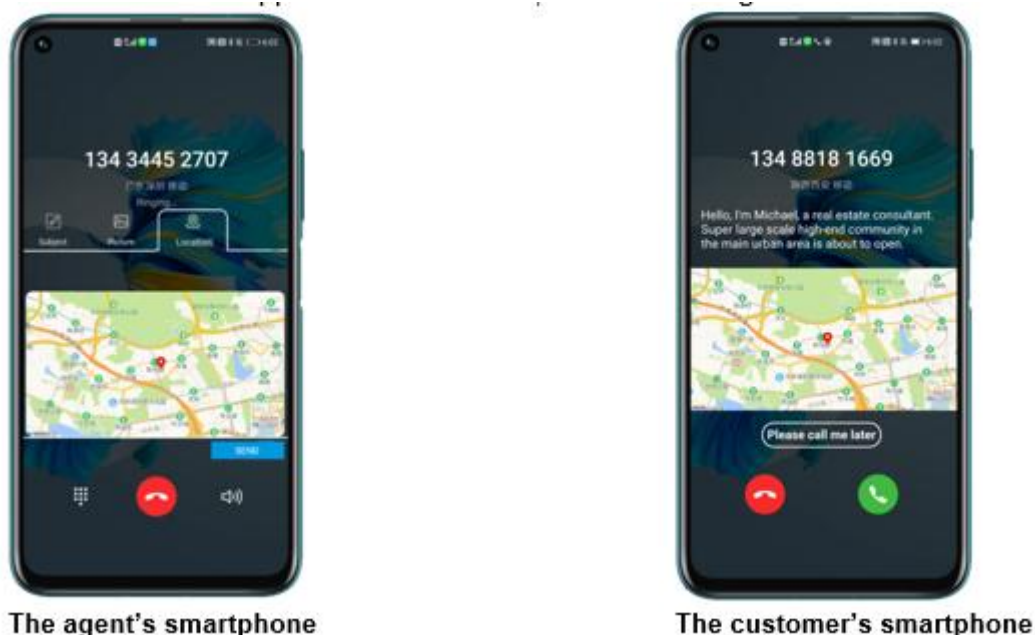

Figure Error! No text of specified style in document..5-4: The real estate agent sends the location of the real estate property

- The called party's mobile phone might have two display modes: collage or carousel. Collage display mode is the called party experience when one-by-one mode is used. The called party display is built gradually as information is added. When all-in-one mode is used then carousel-like behaviour is experienced. Carousel display mode is the horizontally scrollable content made available to the called party who can scroll across the tabs to see what the caller intent is and decide whether the call should be accepted.
- Based on the context, the customer decides whether to answer the call.

15 Interactive Ringback Tone

The ringback tone is a very popular value-added service in the Asian market making it an ideal target for personalization, and enabling its subscribers to serve dedicated commercial or self-created content. This consumer service creates the new multimedia trading channel which is enabled by the data channel interactivity. The calling party is stimulated to take some actions that express their attitude or preference with respect to the served pre-call content. Those actions can be used to drive the consumer loyalty when free content is distributed, or can drive revenues when premium content is made available at some charge.

The interactive ringback tone is a subscription-based service offered to the consumer segment and it uses IMS data channel technology. A consumer using this service needs to have access to the available content list and select the multimedia ring back tone to be served to the calling party. The multimedia is served by the communication service provider owned platform and the content can be served both on-net and the off-net over 5G

interconnect. The communication service provider makes the content available to the subscribed parties and it might be operator created content or 3rd party content for which the licence has been acquired. The multimedia ring back is a pre-call service and does not require the subscribing party to have a data channel capable UE. The service front end uses two media types to deliver the new interactivity and the trading business logic.

1. Multimedia ringback: uses IMS media type "Video", defined in GSMA PRD IR.94 [18].
2. Interactivity: uses data channel media type to implement the interactivity and the ring back business logic.

The combined ringback content with IMS data channel enhancements represents the original content type adapted for IMS data channel and it is a new content type.

The user interface is shown in Figure 6.1.6-1. It plays the content to the calling party, which is the new music video published by the called party's favourite pop singer.

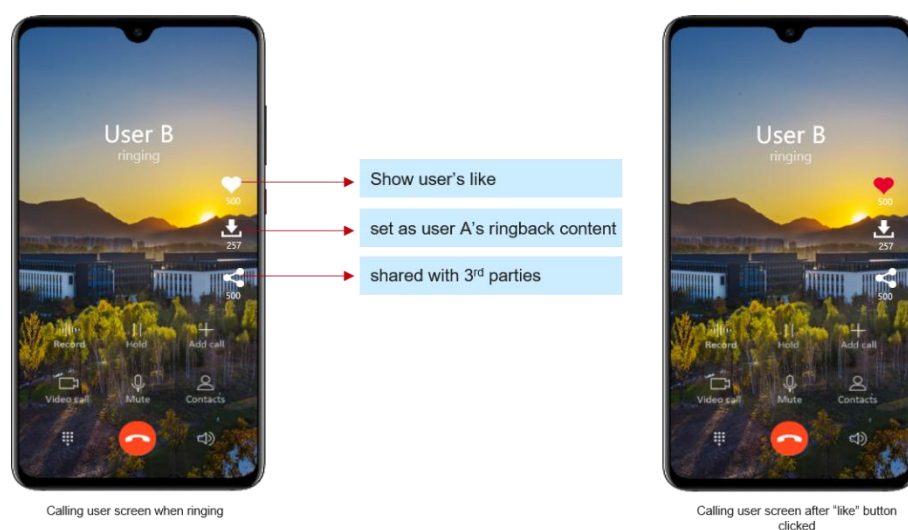

Figure Error! No text of specified style in document..6-1: Example of interactive ringback tone.

The typical user stories are described below:

An on-net call is one where both parties are on the same provider's network:

1. User A uses a smartphone to call user B who has a contract with the same communication service provider.
2. During the ringing stage, a popular content (i.e. a video) is served to the user A. Which content to be served is configured as part of user B's ring back tone subscription.
3. When a video is served, a menu of interactive actions represented by some icons or buttons is displayed as an overlay on top of the video, enabling user A to select an action.
4. The user preference is expressed by the menu selection, for instance user A may become a new subscriber of the ring back tone service with the content set to the

currently played content, or, if allowed, user A may download the currently played content, available as an on-net only service. Alternatively, menu items may be shared with 3rd parties, or ranked through "likes", posted to social media, etc.

5. Once the action is taken the user might be charged. It depends on the option selected.
6. If the A-party does not take an action when video is played, then the A-party can no longer take any action related to the ringing stage

An off-net call is one where each party is on a different provider's network:

1. User A uses a smartphone to call user B who has a contract with a different communication service provider.
2. During the ringing stage, a popular content is served to the user A. Which content to be served is configured as part of user B's ring back tone subscription.
3. When a video is served, a menu of interactive actions represented by some icons or buttons is displayed as an overlay on top of the video, enabling user A to select an action.
4. The user can save a link to content, and/or rank the served content with "likes" on the called party content portal.
5. If the A-party does not take an action when video is played and B-party answers, then the A-party can no longer take any action related to the ringing stage

Service logic similar to the ringback service might be used by the service provider to inform the calling party about the pre-paid balance, try-and-buy offer or some other commercial opportunities. While the previously described user stories required an explicit subscription to the service, the service provider centric content would be served without such a requirement. The service would be triggered by the service provider based on a particular commercial event taking place.

Communications service provider centric call example 1:

1. User A uses a smartphone to call user B who has a contract with the same or a different communication service provider.
2. During the ringing stage, User A's service provider delivers their own selected content (e.g. remaining data bucket is 6 MB) is served to the user A.
3. When the content is shown, a menu of interactive actions represented by some icons or buttons is displayed as an overlay on top of the content, enabling user A to select an action.
4. The user preference is expressed by the menu selection, for instance user A can select to top up another x MB for y USD.
5. If user A does not take an action when video is played and user B answers, then user A can no longer take any action related to the ringing stage.

Communications service provider centric call example 2:

1. User A uses a smartphone to call user B who has a contract with the same or a different communication service provider.
2. During the ringing stage, user A's service provider delivers their own selected content (e.g. sales pitch for a new phone model from vendor V).
3. No further interaction required by the consumer.

16 Data channel application with enabled Resume from the point you have left off

The data channel application and session context is useful for proper engagement with the applications especially when longer history is required for scoring or personalizing application. There are many scenarios, both normal and abnormal, when the specific session cannot be completed and yet re-initiating the application from the initial state is disengaging for users. For instance, when users are playing a game as described in the user story "Social Gaming", and they cannot continue it from where it was left off but need to start the game anew or when making an order for a product which for connectivity reasons cannot be processed, people don't want to start ordering from the start but rather continue from where they lost the connectivity as to avoid entering again the same details.

The "resume from the point where you left off" feature may be used where data channel application was suspended due to notification, e.g. thermal mitigation, network initiated disconnect or JavaScript exception. This feature needs to be enabled by data channel capable of UE so users have the option to select whether the applications will save the context or not. That can be done as part of general consensus or for a specific application but once enabled the UE will be in "state retention" mode and the context storage feature will be enabled.

Chess Game with enabled Resume from the point where data channel application ended

Within the gaming industry the Automatic Resume feature is judged important as it permits players to switch between games and keep the game engagement high. The data channel applications need to offer feature parity for the gaming experience and the convenience to suspend and continue later the play. This user story shows two users playing a chess game together as follows:

1. The user A calls their "chess friend".
2. The user is prompted in-call to enrich the call with interactive content (provided by the data channel).
3. Once a voice session is set up, the user selects a JavaScript Chess application to be loaded on both devices.
4. The user and "chess friend" play the game of chess, with the game status displayed on the screen. As players make the moves the application sends and receives the data media required to provide the interactive game experience and updates the game display.
5. As game progressed User A moved Knight from the original position on b1 to c3, but immediately after the move has been made the UE entered into the thermal mitigation mode since it was executing other unrelated to chess game computationally intensive tasks that resulted in session and the chess game being suspended.

NOTE: In the following other scenarios, the same handling could apply security notification, network initiated session termination and JavaScript exception e.g. memory , security or run-time exception. In the case of JavaScript exception, the data channel application should execute the recovery logic in the JavaScript catch block and be loaded automatically with the most recent state. All this should happen in the background without user intervention therefore steps 6 and 7 below are not required as there is no user action required.

6. After some time when terminal recovered, User A calls back his “chess friend” to continue the game.
7. Once a voice session is set up, the user selects a JavaScript Chess application to be loaded on both devices. User A might be prompted if he wants to continue playing from the last saved context. Application is loaded and both User A and “chess friend” see the game in the most recent state. User A Knight is in position c3 and the other player pieces are in the most recent positions.

[1] NOTE: The application resumption from point where it was left off works the same way regardless of who of two players will latter originate the new session and continue the chess game. And the game context is maintained for a configurable duration, e.g. week, supporting resumption duration optimal for a specific use case.

8. They continue the game with User A winning. Once the game is completed session is terminated by one of the players.

The state retention technical feature in this case encourages players to continue interacting with the game by reminding them where they left playing. It also provides the convenience of not losing any context over the exceptional events and network disconnects.

16.1 Enterprise Segment

17 Enterprise Caller ID and Intent

3GPP TS 24.607 [35] defines Calling Line Identification Presentation (CLIP) which transmits the calling party number to the B-party but only 3GPP TS 24.196 [36] defines Caller Name Presentation (CNAP) which delivers the name associated with the caller. Both enhance the call comfort and help the called party decide whether to accept the incoming call. Non-3GPP solutions also exist, especially in the context of enterprise identity (ID). For instance, today, a third party yellow pages application can be used by the called party or the called party’s network to look up the calling party’s ID and display the associated name. The mechanism is implementation specific and not universally available.

Therefore, there is clear requirement for identity authentication/assertion concerning the ID of the calling party, the enterprise ID in this case. The requirement is found in section 5.6 of 3GPP TR 22.873 [37] describing 3rd party specific user identities. The Application-to-Person

(A2P) application might transfer the enterprise ID to the called party which is obtained from the dedicated enterprise platform. When brands cooperate with Communication Service Providers (CSPs) then the trust associations can be implemented by technical mechanisms such as digital certificates.

Note: Enterprise ID certification is outside the domain of the data channel and the registration of this identity with IMS is the subject of future standardisation.

This results in the new enterprise ID trust ecosystem. The ID assertions are reliable, supported by trusted associations between enterprise and service provider and transported by an IMS data channel secured by DTLS certificates. The relationship between brand and consumer is now certified by the communication service provider intermediary. At a minimum when an employee initiates a phone call through the enterprise specific application, their enterprise identity (company/employee ID/name/card photo) will be automatically delivered to the called party's screen through the IMS data channel between the Data Channel Server and the called party's UE. Once delivered jointly to the called party, the ID assertion and call intent increase the call acceptance rate, therefore improving communication channel effectiveness from the enterprise perspective.



Figure 6.2.1-1: Example of Enterprise Caller ID and Intent

The typical user story involves the brand calling a consumer using an enterprise specific application with the following steps taking place:

1. The brand employee, the calling party, logs into their enterprise A2P application.
2. The application completes the enterprise specific identity authentication. It registers with the IMS network. The enterprise ID as well as enterprise information is obtained

by the IMS network from the enterprise during the network registration procedure. The calling party calls a company customer.

3. The service provider network identifies the originating call as a verified enterprise, then it pushes the calling party's ID assertion using the IMS data channel to the called party's screen before the call is answered. The ID is trusted because it is supported by the existing ID trust associations. The call intent set in advance might also be delivered to the called party's screen.
4. The called party's mobile phone rings and displays the calling party's enterprise ID and call intent. The called party UI indicates to the subscriber that ID of calling party is "Certified". Based on the enterprise certified ID and the call intent, and any other content the enterprise may want to provide (e.g. pictures, animations, videos), the called party might decide to answer or reject the call.

18 6.2.1 Enterprise Interactive Ringing Service

The scenario is the enhancement to the Customized Ringing Signal specified in 3GPP Release 16 TS 24.183 [6], but the enterprise specific content is being served and the enterprise specific engagement scripts are served. The data channel served content is used to convert caller into consumer, to collect consumer feedback or inform a general caller about the company or its profile.

It is a calling party service offered on subscription basis to medium and large enterprises which have online presence supporting e-commerce services.

The data channel technology is used both to interact with the customer as part of ongoing business process completion and to engage the customer in new activities. The data channel media type is used to deliver two different business capabilities:

1. Customer care functionality uses the data channel to deliver interactive scripts to complete a particular business activity like goods delivery, warranty, etc. The interactive scripts are hosted either by the DCS or they are hosted on the enterprise web server.
2. Commercial functionality uses the data channel to provide the online information access and the integration with the company transactional and customer care back end. The delegated authorisation and authentication are used to provide seamless user experience. OAuth can be used for the delegated authorisation to access the e-commerce web page. The service front end uses two media types to deliver the new interactivity and the business logic:
3. Multimedia ringing: uses IMS media type "Video", defined in GSMA PRD IR.94 [18].
4. Interactivity: uses data channel media type to implement the interactivity and the ringing business logic.

Both use the IMS APN to support UE to enterprise interactivity.

An example user interface is shown below.



Figure 6.2.2-1: Example of Enterprise interactive ringing service

The typical user story for the enterprise develops as follows:

1. A courier of an express-delivery company uses their smartphone to call a customer informing them about the parcel delivery.
2. When the customer's smartphone is ringing, a video clip about the express-delivery company and the parcel are displayed, including the picture of the delivery person and the parcel.
3. The called party is served an option of choices such as accept delivery, route to different address, reject delivery, request calling party to call back in 10 minutes, or access the company's website for detailed information on the parcel, etc.
4. The called party can decide to accept or reject the delivery. It will lead possibly to the call termination. The ringing application will terminate the call.
5. If the called party accepts the call, then it can interact with the calling party and once the call is set up, the customer is able to interact with the company and its website.
6. If the called party ignores the call no actions will be taken.

19 6.2.2 Remote Experts

One challenge for an enterprise or business is that many complex work tasks require collaboration between users and experts. Experts are few, costly and only available in a few geographical locations. An expert in any field could become a globally available remote expert, by being able to interact over 5G with other humans and machines, to enable cost-efficient and speedy remote support.

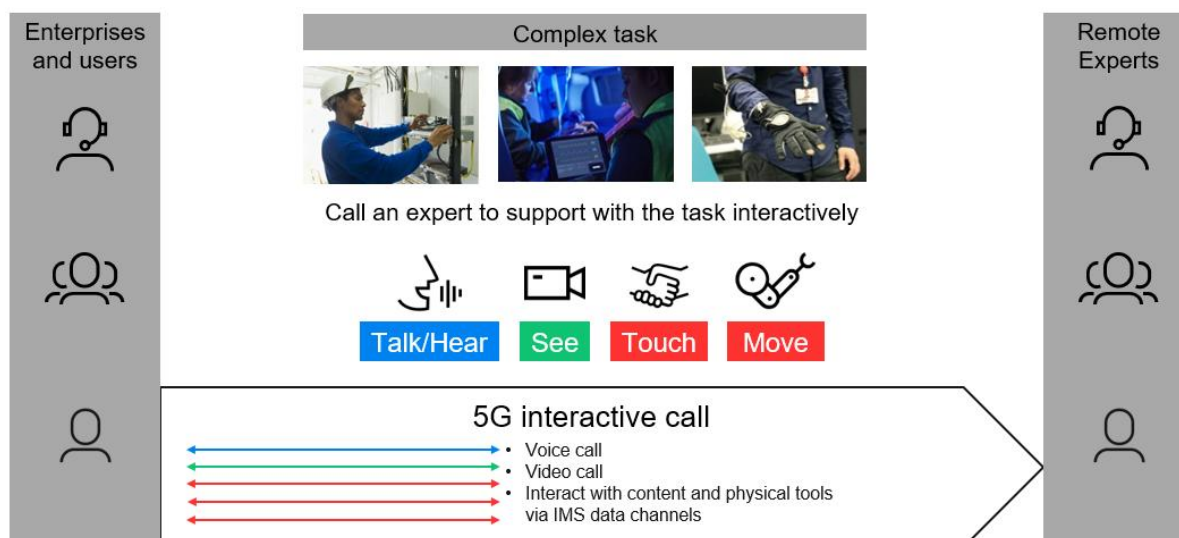

Figure Error! No text of specified style in document.-1: Bring in a remote expert easily via a 5G interactive call.

Here are some examples of enterprise or business user stories which make use of the interactive calling concept, using the IMS data channel over 5G:

1. Remote examinations: the user story in this demonstration; voice, video communication and data channel to support haptic interaction
2. VR with collaboration: voice, video communication and data channel for collaboration application
3. Remote haptic control: voice, video communication and data channel to support haptic control
4. Remote support: voice, video communication and data channel for AR overlay on device
5. Remote surgery: voice, video communication and data channel for remote haptic control
6. Field Support with AR: voice, video communication and data channel for AR in headset

The steps involved are as follows:

Figure 4The user calls a remote expert.

Figure 5The user is prompted in-call to enrich the call with interactive content (provided by the data channel).

Figure 6Once a voice session is set up, the remote expert selects the relevant JavaScript app to be loaded on both devices which is used to provide the expert service.

20 IMS Data Channel Beyond MMTEL

The IMS data channel allows real-time communication between any two endpoints as long as the capabilities of both end points are compatible and in agreement. 3GPP TS 26.114 [1] focuses on data channel from an MMTEL point of view and as such has a very specific set of requirements to offer telephony services. MMTEL requires interoperability for the media and protocols across all devices making it important to have a common framework which can be reused across all devices. With this in mind, WebRTC specification has been positioned as

the mechanism to initiate MMTEL focused IMS data channel capability with references to the W3C work and IETF RFC 8831 [43] and RFC 8864 [4]. WebRTC is a good choice for real time communications and there is an existing ecosystem around it.

20.1 Opportunity – IMS Data Channel Beyond MMTEL

The IMS data channel is an extensible capability that can accommodate other protocols in the future and should not be limited to supporting telephony only using a standardised specification such as WebRTC. Standardisation provides a foundation on which innovation can build but often it could stifle the pace of innovation. Consider the scenario below:

1. Operator A wants to provide a new service (within their own domain, in a private network context, no regulation applicable, no interconnect requirements)
2. The new services only deviate in very few aspects from the standardised MMTEL telephony service e.g. different service identifier and different media type (not RTP or WebRTC).
 - a. The new service reuses 99% of the IMS framework
 - b. Same interface between the IMS platform and the mobile core
 - c. Same internal procedures between the IMS client and the 5G modem (establishment of Quality of Service (QoS) enabled bearers, SIM authentication etc.)
3. The primary change is in the UNI interface i.e. IMS signalling and media description

The 3GPP IMS specifications should provide sufficient flexibility to allow equipment suppliers and operators to deploy the above type of service with no “special requirements” being required in their IMS platform. This allows for a bespoke service identifier and “passthrough” media operation where traffic management at the respective 5G core user plane and/or IMS media plane functions can be simply requested based on policies defined by the operator for a particular service and /or media type (e.g. a particular 5QI level and/or media passthrough treatment).

Developers today are replicating many of the capabilities that operators can already provide using IMS technology. They have resorted to using VPN servers to traverse mobile cores, using multiple SIMs to provide resilience, using in-band (ping) mechanisms to test the performance of different accesses, and using application layer encryption and authentication to support security. From an operator’s point of view, there is a need to persuade application developers and service providers to use the IMS platform capabilities by making it easy for them to run their services over our network, and not having to completely change their implementations to use another protocol beyond SIP/SDP.

The IMS data channel provides an opportunity to establish any media type (standardised or not) between two endpoints. The IMS platform can be agnostic to the media type – it only needs to:

4. know the QoS requirements for that media type (could be preconfigured, could involve an IMS Server/Application Function).
5. Potentially police media traffic traversing the SBCs – based on SLA agreements which again, could be preconfigured, but standardised per media type.

The device ecosystem should evolve to an extensible architecture that allows any client to use an IMS-based session as a mechanism to:

6. Authenticate the device to the network and the application
7. Establish QoS-enabled sessions dynamically between two endpoints
8. Security
9. Traverse the mobile core (NAT)
10. Handle handovers, etc.

The work in 3GPP and GSMA on IMS data channel should look to stimulate innovation by providing more than just a fully standardised mechanism to extend MMTEL telephony services. It needs to allow for integration of future applications and protocols as well as encourage an open client ecosystem where the capabilities of a fully integrated IMS client stack can be used to offer new services and revenues.

20.2 Potential Use Cases

Use cases that may not necessarily be Telephony focused or need to use WebRTC but may still want to leverage an IMS data channel capability include:

Figure 7 Remote manual operations (robots, drones, vehicles, cranes, forklift trucks etc.), including the following types of traffic

- a. 360 immersive real-time videos
- b. Command and control traffic
- c. Force feedback
- d. Telemetry information

Figure 8 Remote diagnostics / Connected ambulance

Figure 9 Volumetric video (holographic) real-time communications between multiple endpoints

Figure 10 In essence, any service that requires a secure, QoS-enabled, real-time communications sessions being established dynamically between two end points and uses a non-standardised protocol for two endpoints (which understand the non-standard protocol) to communicate.

20.3 Future Work

This paper calls out the need for flexibility to support non-MMTEL IMS services which could benefit from the IMS data channel but with potentially bespoke APIs and protocol stack. This adaptability will allow specialist solution developers (mostly in the IoT/B2B space) to integrate their own frameworks with IMS thereby leverage existing IMS capabilities without having to retrofit their solutions to standardised specifications such as WebRTC. This is currently viewed as an innovative and vertical approach between specific endpoints for a specific service. There is no immediate standardisation activity expected at this stage but as adoption ramps up and gains ground possible standardisation work could be initiated.

21 Conclusions and Recommendations

The IMS data channel has been validated in simulated environments including lab and field tests. The industry intends to commercialize the data channel use cases enabling action-oriented IMS communications. The main findings of this white paper include:

1. The IMS data channel offers new communication modes enabling IMS intermodal and interactive services with active content execution. It is what is needed to enable innovation.
2. Enhancing the IMS platform with the WebRTC data channel has the potential to attract the web developer community thanks to the use of JavaScript and its associated toolchain. That by itself might generate consumer value-added and create a new market. WebRTC data channel use with GSMA PRDs IR.92 [8] and IR.94 [18] media types still need to be promoted to web developers.
3. The use cases described in this document can be supported by existing standards. 3GPP TS 26.114 [1] has all the required core network provisions to enable IMS data channel although it has some underspecified areas (e.g. DCS interface specification, Data Channel API) that might hinder multi-vendor interoperability but not the commercial potential of IMS data channel.
4. Lack of native UE support for 3GPP TS 26.114 [1] defined IMS data channel, is the main obstacle to mass market adoption of data channel services. It is especially important that open market devices support the IMS data channel.
5. Operating System and chipset vendors play a critical role in enabling native IMS data channel support.

This white paper recommends the following actions to further develop the ecosystem and improve the quality and completeness of the technical specifications:

6. Ecosystem recommendations
 - a. The industry needs IMS data channel success story and all parties should work to launch IMS data channel services, and to identify and promote innovative user stories.
 - b. Interested communication service providers (CSPs) and vendors to work together to promote the IMS data channel development and specifically facilitate the release of open-source plugins, code examples and the application environments to attract developers. For instance, a lab could be created by GSMA to promote the IMS data channel technology.
 - c. Finding methods to motivate OEM vendors to support the IMS data channel natively is critically important therefore making IMS data channel support mandatory in GSMA PRD NG.114 [9] might be one option.
 - d. The developer community is critically important for the development of this market. Easy access should be promoted.
 - e. Operating system and chipset vendors need to be actively engaged in the IMS data channel evolution and need to help the industry to co-evolve IMS data channel as defined by 3GPP TS 26.114 [1] and WebRTC as defined by W3C WebRTC 1.0 Recommendation [39]. It needs to be made clear whether two implementations of WebRTC will be required on the UE as noted in Annex G describing W3C standardisation status.
7. GSMA recommendations

- a) IMS data channel evolution and profiling should follow general GSMA rules and it should be based on a single architecture to prevent the industry from splitting and being indecisive on which path to follow.
 - b) Develop GSMA IMS data channel PRD specifying the minimum mandatory set of features which are defined in 3GPP and GSMA specifications that a wireless device (UE) and the network are required to implement in order to guarantee interoperable, high quality IMS data channel services over 3GPP access.
 - c) Develop GSMA specific (or co-develop with 3GPP) IMS data channel APIs to be used between the DCS and the MMTel AS (i.e. IF6 as described in Annex A) and between the DCS and the MRF (i.e. IF1 as described in Annex A). It would profile a minimum subset of the resources and HTTP methods that must be supported by any entity conforming to the DCS definition.
8. Other Standards Developing Organizations (SDOs) including 3GPP, IETF and W3C
- a) Where issues of critical importance are identified, GSMA will inform the appropriate SDOs.

Further data channel development requires from the industry (e.g. network operators, vendors and device OEMs) to undertake the following actions:

- a) Complete the required GSMA profiles describing minimal set of requirements.
 - b) Initiate activity to standardize data channel API.
 - c) Complete the data channel promotion and awareness campaign.
 - d) Complete trials and release the findings through the operator story platform.
 - e) Develop the catalogue of developed and deployed user stories.
 - f) Complete the development of core network products.
 - g) Reach critical mass of OEM native support for data channel.
 - h) Have support for data channel from major device operating systems.
 - i) Develop IMS data channel business case examples.
- a) Complete the data channel toolchain and release it to the developers for free.
 - b) Attract developers and create the marketplace.
 - c) Create an application marketplace/App Store.
 - d) Promote data channel success stories with clear explanation of the value added.

All or subset of above actions would benefit the IMS data channel ecosystem.

The key industry milestone is making native data channel available on all UEs and attracting developers to this market. An industry wide data channel platform, perhaps supported by a dedicated Memorandum of Understanding (MoU), should be created either by the open source community or GSMA.

Annex A Data Channel Architecture

3GPP TS 26.114 [1] specified some structural properties of data channel technology, assigned names to the data channel specific network functions but left the reference points and interfaces undefined. No names are given to the interfaces and functional description of the newly named network functions are not completed. The non-normative description of data channel relations that serves as the basis of architecture is based on the “workflow” in Figure 6.2.10.1-1 of 3GPP TS 26.114 [1] shown in Figure A-1.

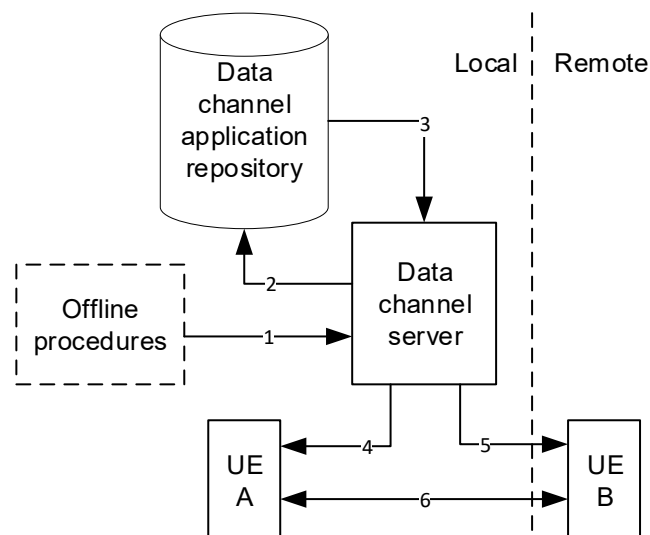

Figure A-1: IMS data channel workflow defined in 3GPP TS 26.114 [1]

The IMS data channel 3GPP functional aspects are underspecified leaving room for interpretation on how to implement it and this could imply no guarantee for multi-vendor interoperability.

Therefore, there is the need to identify a minimum mandatory set of features which are defined in 3GPP and GSMA specifications and are required to guarantee interoperable, high quality IMS data channel based services.

Figure 6.2.10.1-1 of 3GPP TS 26.114 [1] provides a “workflow” which should be further mapped into a more detailed 3GPP style architectural model which would then be referred to by GSMA or in other 3GPP documents.

The proposed architecture describes all the required reference points and interfaces. It also outlines the responsibilities of data channel specific network functions and are built on existing 3GPP defined logical entities and reference points where possible, to avoid standardizing new functions and reference points. The objective is to minimize the impact of IMS data channel on 3GPP specifications and GSMA PRDs.

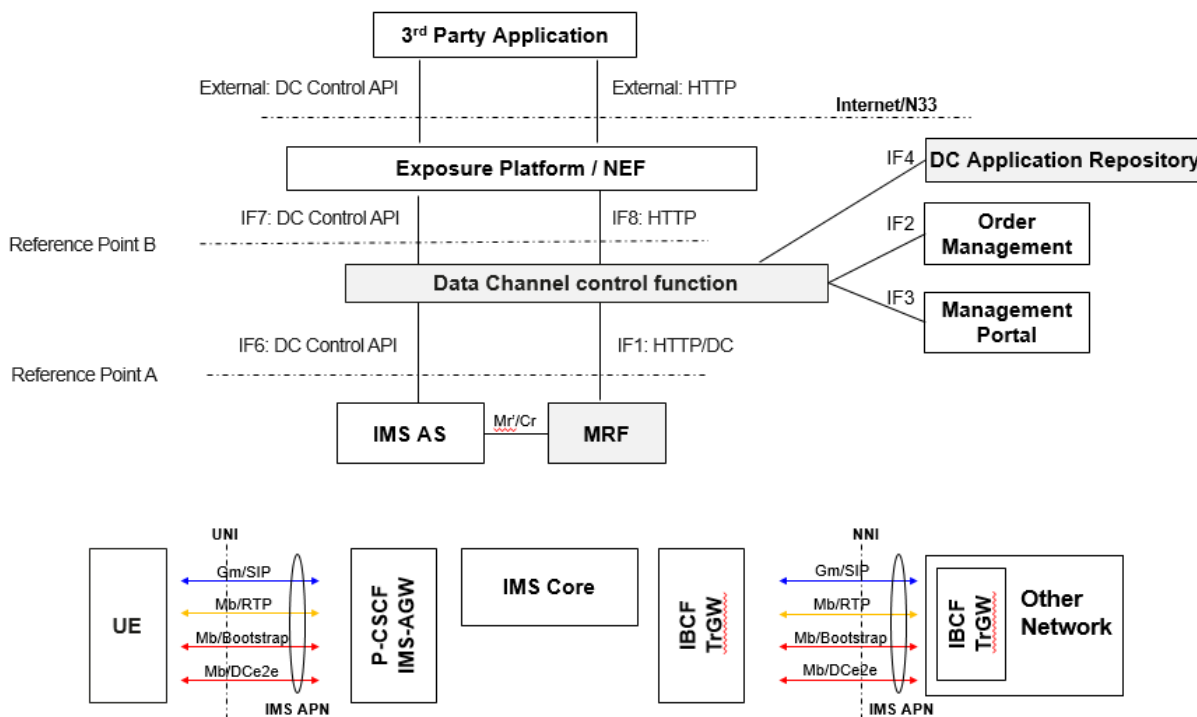

Figure A-2: GSMA approved data channel architecture.

An IMS data channel reference point is defined as a conceptual point at the conjunction of two non-overlapping network functions.

An IMS data channel interface is the common boundary between two associated network functions.

Table A-1 describes IMS data channel reference points defined in Figure A-2.

Reference Point	Function	Supported Interfaces
A	Represents the boundary between the IMS subsystem and the data channel subsystem. The IMS data channel subsystem is not involved in any processing of GSMA PRD IR.94 [18] “video” and GSMA PRD IR.92 [8] “speech” media type operations.	IF1: data channel media interface IF6: data channel control interface
B	Represents IMS data channel external network boundary between the communication service provider and the web.	IF7: data channel control interface IF8: data channel media interface

Table A-1: IMS Data Channel Reference Points

Note: The interfaces/API defined in Table A-1 might be subject to a new definition, or might become an extension of GSMA OneAPI.

Table A-2 describes the IMS data channel network functions shown in Figure A-2.

Network Function	Description
Data Channel Server	<p>Control Functions</p> <p>Implements data channel business logic using DC control API.</p> <p>Initiates and terminates the bootstrap and application data channel control procedures.</p> <p>Note: For UE to UE, the Data Channel Server (DCS) is not involved in the termination of data channel.</p> <p>Provides data channel management statistics and alarms.</p> <p>Media Functions</p> <p>Supports data channel interworking towards internet/intranet.</p> <p>Provides the execution environment for IMS data channel application logic when necessary and interacts with UE (i.e. Application-to-Person/Person-to-Application (A2P/P2A) cases). When the application uses HTTP media type then it provides the functionality of web server and when other media types are used then it implements their related media type server capabilities.</p>
MRF	<p>IMS data channel media function</p> <p>Executes IMS data channel media operations such as creation and closure of bootstrap data channel(s).</p> <p>Initiates and terminates connectivity for the bootstrap data channel(s).</p> <p>Initiates and terminates connectivity for the application data channel(s).</p> <p>Note: the actual procedures and data channel terminations are performed by the DCS.</p> <p>Interworks with the related data channel media servers and encapsulates data channel media content into the application channel stack.</p> <p>IR.92/94 media function</p> <p>Executes GSMA PRD IR.94 “video” and GSMA PRD IR.92 “speech” media type operations (i.e. media playing, recording, collecting digits, and mixing audio/video against IP media streams).</p> <p>DC gateway</p> <p>Provides the reference point and capability for UE to reach the Internet over IMS APN via the DCS.</p> <p>MRF act as a gateway between the IMS domain and web domain (via DCS). Data channel media is carried over the 3GPP defined Mb reference point therefore to breakout outside the IMS domain, this Mb traffic must pass through a gateway.</p>
Data Channel Application Repository	<p>Backend network functionality providing only the storage for the IMS data channel applications.</p>
IMS-AGW, IBCF/TrGW, IMS-ALG, P-CSCF, PCF	<p>Support for data channel QOS handling between IMS and Packet Core (PCF)</p> <p>Support for WebRTC data channels.</p> <p>Note: IMS-AGW might need to support the IMS data channel anchoring for Lawful Interception, topology hiding, or statistics.</p>

I-CSCF, S-CSCF	IMS data channel services have no specific requirements on these network functions.
IMS AS	<p>Uses the Data Channel Control API for allocating data channels with DCS.</p> <p>Support the data channel specific interaction needed for media control of the MRF for Mb to IF1 connectivity.</p> <p>Note: IMS AS is a generic term for any application server supporting IMS data channel usage, e.g. MMTEL AS, SIP Trunking AS.</p>

Table A-2: IMS Data Channel Network Functions

Table A-3 describes IMS data channel interfaces in Figure A-2.

Interface	Function	Protocol
Mr'/Cr	<p>Used to exchange session controls between AS and MRFC.</p> <p>Note: In the future the Mr'/Cr interface might evolve to become a new service based interface.</p>	SIP/SDP and XML encoded media service requests
IF1	Used to deliver data channel media to the UE.	HTTP
IF2	Used for provisioning data channel service data which originates from related business catalogues and is populated using the order management, including "Offline procedures" as defined in Figure 6.2.10.1-1 of 3GPP TS 26.114 [1].	HTTP
IF3	Used for managing operational aspects of the DCS, including "Offline procedures" as defined in Figure 6.2.10.1-1 of 3GPP TS 26.114 [1].	HTTP
IF4	Used to store data channel applications in the backend data base.	Implementation specific
IF6	DC Control API used to implement the data channel business logic.	HTTP/RESTful
IF8	Used by AF to serve the content to UE.	HTTP
IF7	Used by AF to control data channel business logic.	HTTP/RESTful

Table A-3: IMS Data Channel Interfaces

Note: Other data channel architectures might be possible, however until 3GPP provides the guidance no other data channel architectures will be described by GSMA.

A.1 Data Channel Protocol Stack

The conversational multimedia applications are transported over RTP with respective payload format mapping to the RTP streams. For data channel media, SCTP over DTLS stack is used as specified in 3GPP TS 26.114 [1].

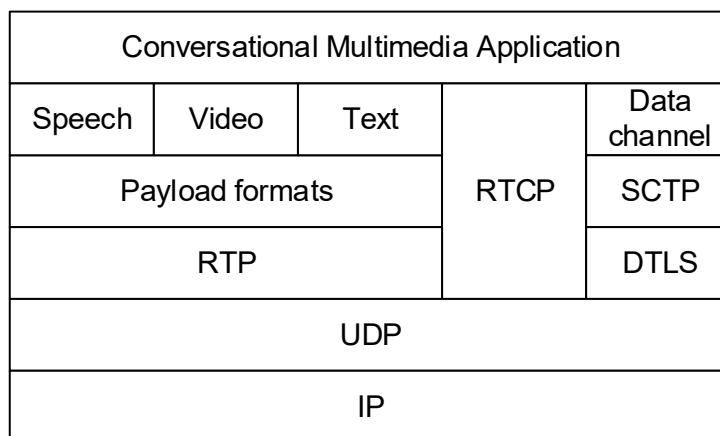

Figure A.1-1: User plane protocol stack for a basic MTSI client

The well-known "multi-homing" SCTP is not suitable to be used with the data channel since an application cannot separate the signalling paths, and it is also not considered feasible when using SCTP on top of DTLS (a connection-oriented, unreliable datagram service). The SCTP layer will simply act as if it were running on a single-homed host. The host's IP address, UDP port and SCTP port should be constant in one SDP media description. If there is a need to use the data channel with different IP addresses, different UDP ports, or different SCTP ports, then separate data channel SDP media descriptions must be used. As specified in 3GPP TS 26.114 [1], data channel session setup shall determine the following session parameters, and additional session parameters may be determined depending on specific cases:

1. IP address(es)
2. UDP port number(s)
3. SCTP Port number(s)
4. DTLS server/client role(s)
5. DTLS ID(s)
6. Stream ID(s)

The SCTP Stream ID is used to build up the bootstrap and end to end connection, and the IP/UDP/SCTP parameters are used to set up the SCTP over DTLS association. IETF RFC 8864 [4] specifies that the 'dcmmap-stream-id' parameter indicates the SCTP stream ID within the SCTP association used to form the data channel.

The following 3GPP reference points may need to be enhanced to support the data channel protocol stack:

3GPP Component	Reference Point	Protocol	Function
NEF	N33	HTTP	Used to serve data channel content to a UE
PCF	N5	HTTP	Used for QoS hint processing
UE	Gm	SIP/RTP	UNI support of data channel signalling and the data channel user plane
IMS-AGW	Mb	RTP/RTCP	Anchoring of data channel sessions
IBCF	Ici	SIP	NNI support of data channel
MRF	Cr/Mr'	SIP/SDP and XML encoded media service requests	Data Channel Media Operations
TrGW	Izi	RTP	
DC Gateway		HTTP over TCP	Anchoring of IMS Internet Access. Connectivity between the User Plane Function and Internet

Table A.1-1: 3GPP reference points which may need to be enhanced to support data channel

The data channel protocol stack used for the signalling and the user plane are described below.

The IMS signalling plane is mandatory for the data channel as shown in Figure A.1-2 were

1. SDP is used to describe the application data channel and its requirements
2. Data represents the 3GPP TS 26.114 [1] media component "Data"

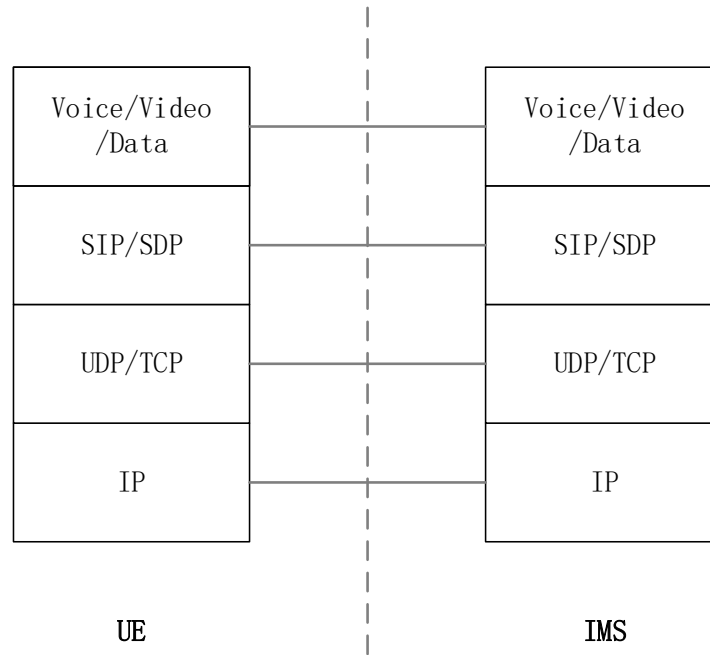

Figure A.1-2: UNI signaling plane stack: Gm interface.

The bootstrap data channel user plane for the P2P scenario uses the protocol stack from Figure A.1-3. All data channel protocol anchoring is done within the IMS subsystem.

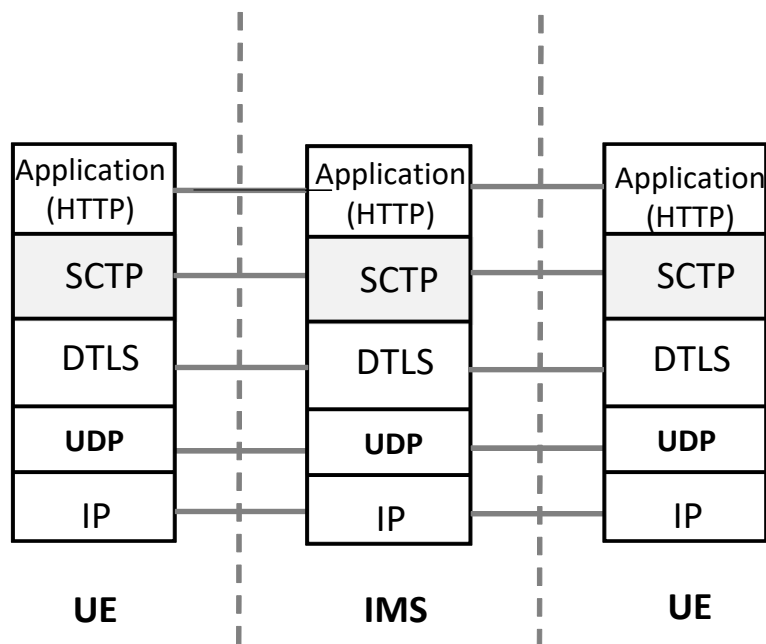

Figure A.1-3: IMS P2P UNI-UNI user plane: Mb interface

The bootstrap data channel protocol stack for A2P/P2A scenarios needs to interwork with enterprise systems using data channel capable trunks. A data channel capable trunk is an IMS trunk enhanced with the data channel protocol stack capability for the user and signalling plane. When interworking with Enterprise systems, RFC 3234 [14] defined

components might be placed in the path of HTTP but in general there is no requirement for the transport layer interworking. See Figure A.1-4.

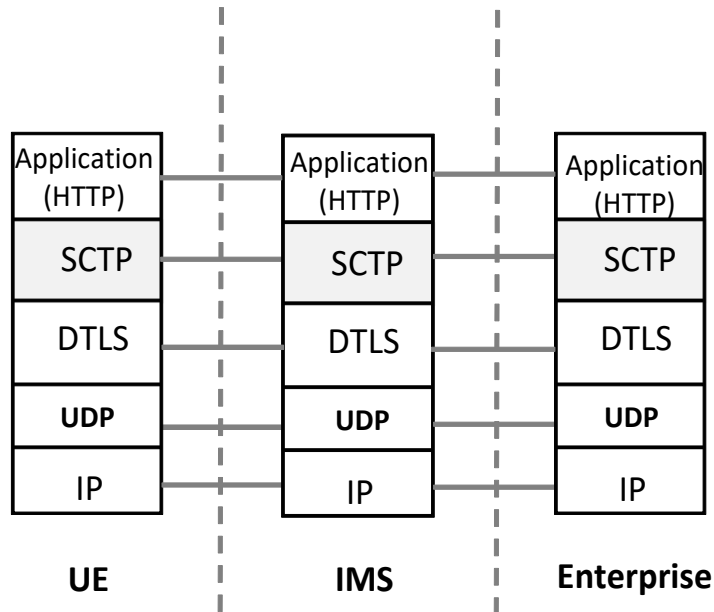

Figure A.1-4: IMS A2P/P2A UNI-NNI user plane: Izi

The data channel application is a web application and as such it can interact with content and web servers located in the Internet domain. Such interworking requires transport level interworking between the IMS system and the web server due to the differences in the transport layer. See Figure A.1-5 below.

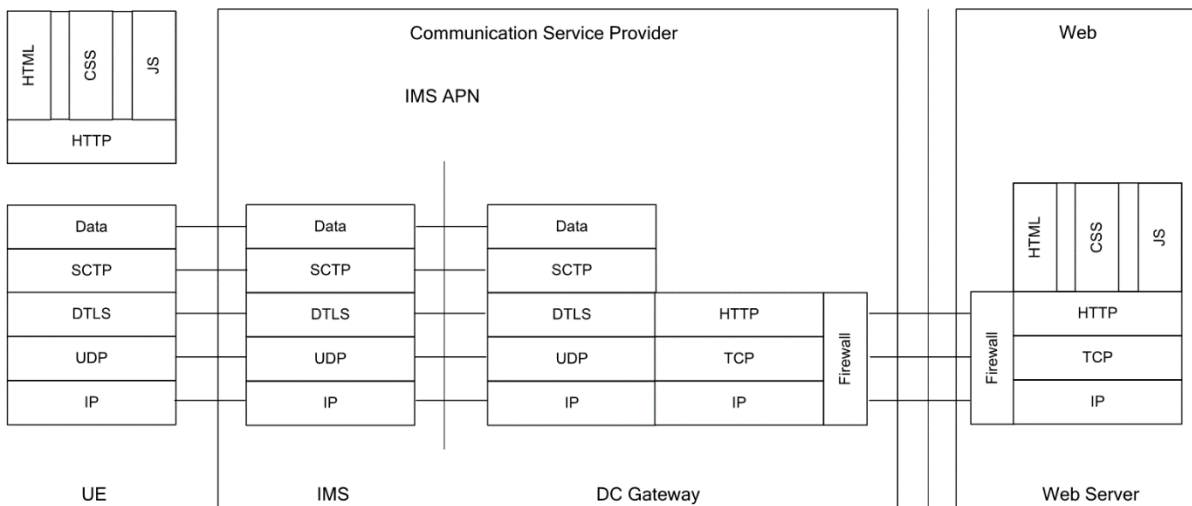

Figure A.1-5: A2P/P2A UNI-NNI user plane

End-to-end (non-bootstrap) data channels can be used by both P2P and A2P/P2A scenarios. The protocol stack for end-to-end data channels is shown in Figure A.1-6 below.

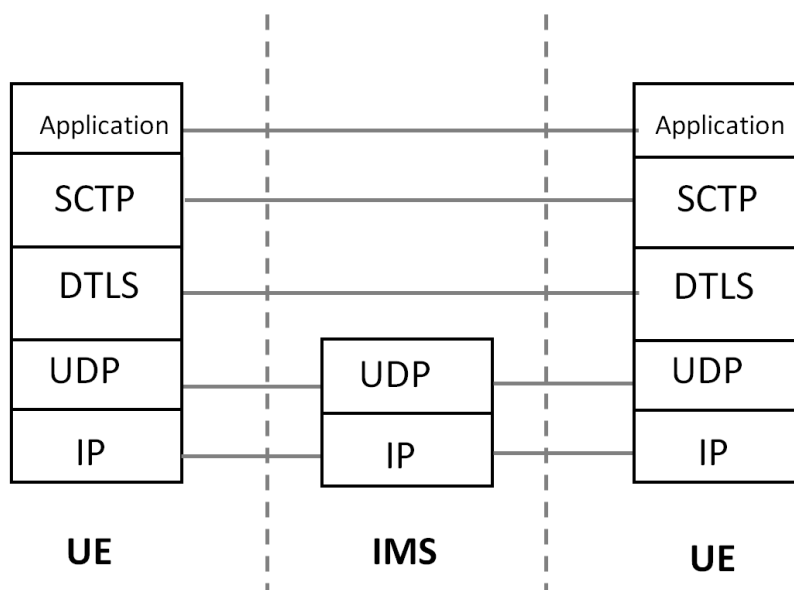

Figure A.1-6: End-to-end UNI-UNI (Mb) and UNI-NNI (lzi) user plane

A.2 P2P/P2A/A2P Data Channel Architectures

The data channel architecture supports P2P, P2A and A2P use cases. The data channel related P2P/A2P/P2A/A2A definitions follow from 3GPP TS 32.274 [12] and are applied accordingly to this document with the following meaning:

1. Person-to-Person (P2P): The session is originated by a UE and terminated on another UE.
2. Person-to-Application (P2A): The session is originated by a UE and terminated on a third party application.
3. Application-to-Person (A2P): The session is originated by a third party application and terminates on a UE.
4. Application-to-Application (A2A): The session is originated by a third party application and terminated on another third party application.

This section describes the key characteristics of the relevant use cases focusing on the following four aspects

5. Architectural differences between the use cases in question
6. The life-cycle of bootstrap and application data channels
7. The interface definitions and their standardization status
8. Identifying any gaps that might pose implementation questions

Data channel cloud deployment models

The data channel application might be deployed in the following configurations:

1. Operator private cloud
2. Public cloud
3. Enterprise private cloud
4. Mobile edge computing

Person to Person (P2P)

P2P Data Channel Architecture

The P2P data channel architecture is shown in Figure A.2.2.1-1.

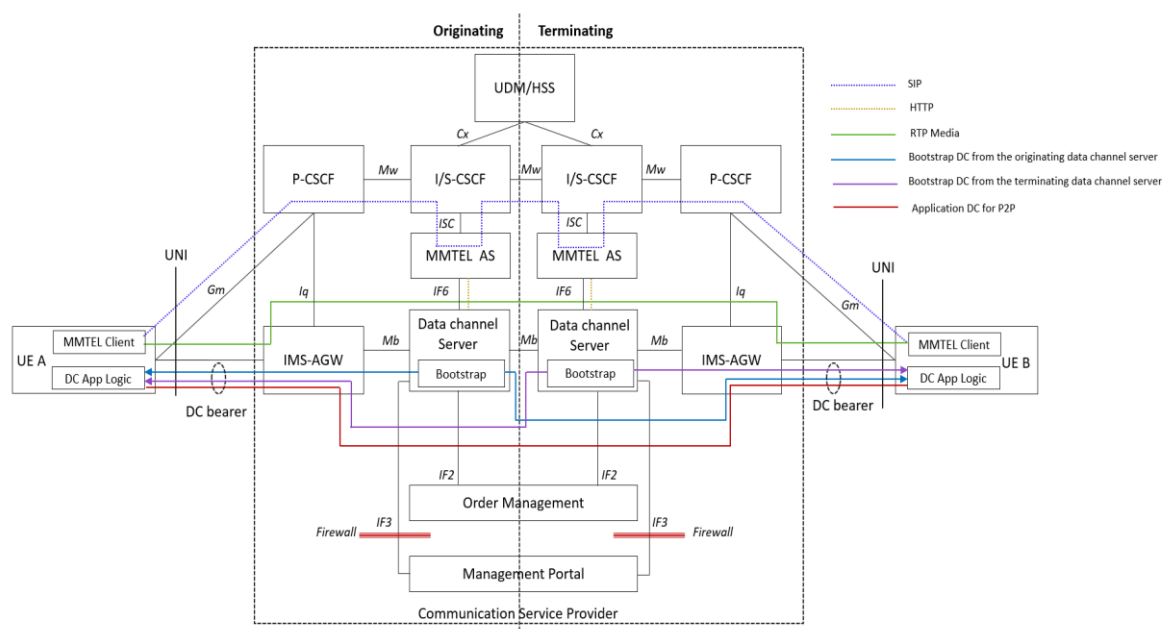

Figure A.2.2.1-1: P2P data channel architecture

The standard 3GPP interfaces definitions apply with the following enhancements:

Note: The data channel media MRF is not shown in Figure A.2.2.1-1 for simplicity, therefore IF1 and Mr'/Cr are not shown.

1. IF6: the interface between MMTEL AS and the DCS is used for reporting the call events. When 5G subscriber initiates a call with the data channel capability specified in section 6.2.10 of 3GPP TS 26.114 [1], MMTEL AS sends the call events notification to the DCS. The DCS subscription information determines whether the DCS should be notified of the particular call. IF6 interface allows the DCS to request the following services from MMTEL AS:

- a) DataChannelCallEventSubscribe: the operation is used by the DCS to subscribe to MMTEL AS call notifications events.
- b) DataChannelCallEventNotify: the operation is used by MMTEL AS to notify the DCS about the related call events.
- c) DataChannelCallControl: the operation is used by the DCS to request from MMTEL AS the establishment of the one-sided or two-sided bootstrap data channel.
- d) DataChannelCallControlNotify: the operation is used by MMTEL AS to notify the DCS about the call control operation result.
- e) MMTEL AS obtains the DCS address through the local configuration or through the DCS subscription events. In case where the DCS subscription events are used the DCS needs to know MMTEL AS address by some means. The DCS address is needed to send the call event notification to the DCS.

The relationship between MMTEL AS and the DCS is that of consumer-producer not peer to peer. The DCS is not a SIP AS.

2. IF2: the interface between the service provider Order Management System and the DCS is used for provisioning data channel service. The service provider needs to provision the DCS with the information concerning subscribers who are allowed to use the data channel services. The DCS is typically provisioned through the SOAP provisioning interface and uses XML format. The data channel does not have new requirements on the provisioning interface.
3. IF3: the interface between the operations systems and the DCS. Its front end supports the CSP management portal. P2P data channel application deployment process uses this interface. The DCS operation/FCAPS are handled in the same manner as MMTEL server. The data channel does not have new requirements on the operational interfaces.

A.2.1.1.1 P2P Application Processing

P2P application processing is depicted by Figure A.2.2.2-1 below.

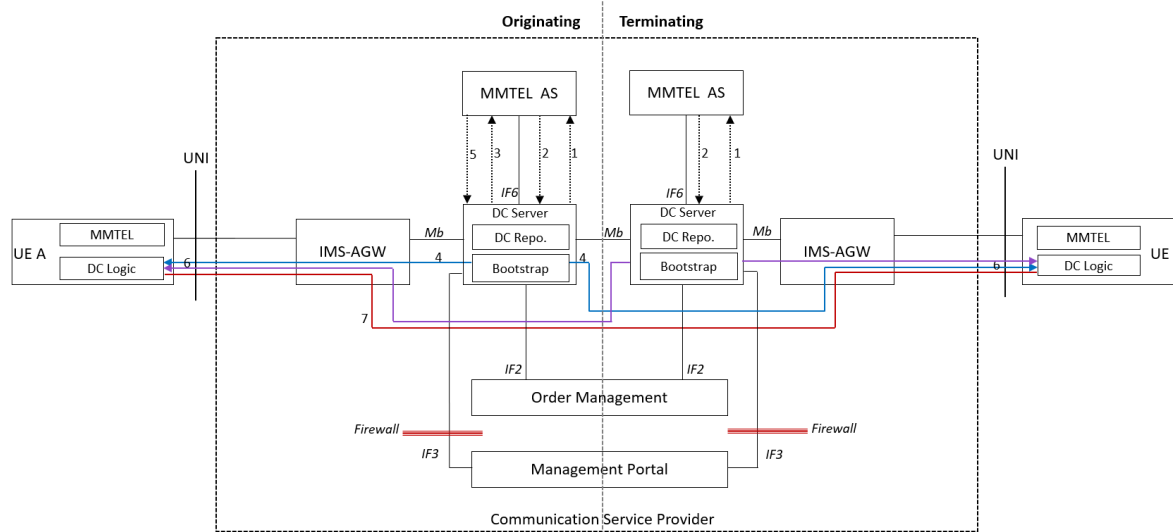

Figure A.2.2.2-1 : P2P application processing

1. The DCS subscribes to an MMTEL call events notification using the subscribe/notify pattern through DataChannelCallEventSubscribe operation. The call events are used as the input for DCS policy analysis. MMTEL AS might interwork with the multiple DCS configured and it will route call notifications accordingly to its policies. For instance, a large enterprise or government might have its own dedicated DCS. Alternatively, the DCS is always internal to the CSP but the DC Repository can be partially distributed so that the DC Server acts as a proxy to access content external to the CSP. Such proxy access can be set to only allow whitelisted content from trusted sources.

Note 1: MMTEL interworking with multiple DCSs is a possible future extension and might be further described as the relevant requirements are documented.

2. After receiving a call event notification through DataChannelCallEventNotify operation, the DCS determines whether to allow the establishment of a bootstrap data channel and the type of the bootstrap data channel based on the local policy and the related parameters in the call event notification. The call event parameters might include the calling party number, called party number, and the data channel SDP parameter (stream-id, label, ordered, max-retr, etc.).

Note 2: The DCS policy analysis is not defined in the standard 3GPP TS 26.114 [1].

3. If the operator data channel policy allows P2P scenario, then the originating DCS invokes the DataChannelCallControl operation requesting MMTEL AS to negotiate the establishment of two separate bootstrap data channels: first towards the calling party and the second towards the called party.

The bootstrap data channels are established between UEs and the originating DCS once the SIP negotiation of the bootstrap data channel capability is successful. The procedure is specified by section 6.2.10 of 3GPP TS 26.114 [1].

There are multiple, possible providers of data channel applications. The mandatory mapping between stream ID and bootstrap channel data channel application content sources are described in Table 6.2.10.1-2 of 3GPP TS 26.114 [1].

4. The data channel service can use data channel applications from originating party, terminating party, or both. Each data channel application needs its own user interface context, e.g. something similar to a browser "tab", so multiple applications can be active simultaneously. Each UE can obtain an application list available to it through its bootstrap channel 0 (local between the UE and its serving network) and can choose what application to use from that list.

For example, the originating UE can see and choose an application in the list from its local DCS to use in a call with the terminating party, but the terminating party has no say in that choice and may not even be presented with the originating party's list. At the same time, the terminating party can see and choose an application in the list from its local DCS to use in a call with the originating party, where the originating party has no say in the choice and may not be presented with the terminating party's list. It is in no way required that both parties choose, but a single choice impacts use of a single application on both ends. If there are two choices, there will be two separate applications.

5. MMTEL AS invokes DataChannelCallControlNotify operation to confirm the operation result. The failure to establish a bootstrap channel does not result in the call release. Once the bootstrap data channel is available, it is used to download the P2P application list based on the application policy specified.

P2P application list includes applications provided by the local users, the local network, or applications provided by remote user or remote authorized party as specified by 3GPP TS 26.114 [1]. The local user provided applications must be uploaded to the DCS prior to the call.

6. The subscriber selects P2P application to be used during the call from the P2P application list, for example, screen sharing. After receiving the application selection request from the user, the DCS enables download of the application through the bootstrap data channel. All required P2P static resources are included in the application.

After the data channel application is successfully downloaded through the bootstrap data channel, the bootstrap data channel is left open during the lifetime of the session, for example to optimize the amount of downloaded bootstrap data based on actual user interaction with the application, ensure the application data is kept up to date with possible content changes on the server, or to allow different applications to be used during the session. If the application is entirely static or if network resources are very scarce, the bootstrap data channel can be closed, as per section 6.6.1 of RFC 8864 [4]. If more or dynamic parts of the application are requested by user interaction, or if a new data channel application needs to be downloaded after the bootstrap data channel is closed, SIP renegotiation is required and a new bootstrap data channel will be established. Any remaining bootstrap channels are released when the call is released.

7. P2P data channel application creates an application data channel based on its functional requirements. The data channel application can specify the loss and latency characteristics in the app.json configuration file. The UE parses the app.json configuration file of the application and maps the latency and loss parameters to the "a=3gpp-qos-hint" line in Table A.2.2.2.2. If no loss and latency characteristics are

specified, best-effort transport is assumed. The PCF shall derive the QoS information as described in section 7.3.3 of 3GPP TS 29.513 [15]. It uses JavaScript to create the application data channel. For example, screen sharing application creates one when a user clicks on the screen to start the screen sharing. As specified in TS 26.114, it is not required to use 3gpp-qos-hint and either one of the networks may downgrade loss and latency values during call setup or call renegotiation to what the networks and subscriptions allow. It is also allowed to remove 3gpp-qos-hint entirely, which would fall back to best-effort transport.

```
SDP offer  
m=application 52718 UDP/DTLS/SCTP webrtc-datachannel  
b=AS:500  
a=max-message-size:1024  
a=sctp-port:5000  
a=setup:passive  
a=fingerprint:SHA-1 4A:AD:B9:B1:3F:82:18:3B:54:02:12:DF:3E:5D:49:6B:19:E5:7C:AB  
a=tls-id: abc3de65cddef001be82  
a=dcmap:10 subprotocol="http"  
a=dcmap:38754 max-time=150;label="low latency"  
a=dcmap:7216 max-retr=5;label="low loss"  
a=3gpp-qos-hint:loss=0.01;latency=100
```

Figure A.2.2.2-2: Example SDP offer with 3gpp-qos-hint.

P2P application data channel is established between the calling UE and called party UE as specified in section 6.2.10 of 3GPP TS 26.114 [1]. It uses the data channel bearers specified in section L.2.2.5 of 3GPP TS 24.229 [2] as its user plane and carries both the application control and content. It is released when the call is released.

The application data channel path is anchored to the IMS-AGW using Gm and Mb interfaces specified in 3GPP TS 23.228 [13]. It is routed over the same path as the RTP voice and video payload. Both IMS bearers and the data channel bearers use the same UPF which is selected according to section 6.3.3 of 3GPP TS 23.501 [11].

The subscriber behaviour triggers the P2P application logic. For example, screen sharing application can create its own application data channel and interact the other party when a user clicks on the screen to start the screen sharing.

Annex B Person-to-Application (P2A)

P2A data channel application architecture differs depending on whether or not the enterprise supports the data channel capability. Therefore, two scenarios are defined:

Person-to-Legacy enterprise Application (P2LA): defines the scenario where the data channel enabled UE needs to interwork with the legacy enterprise systems

Person-to-Data Channel enterprise Application (P2DA): defines the scenario where the data channel enabled UE needs to interwork with the data channel capable enterprise system.

Such an enterprise system supports the data channel stack as part of the enterprise architecture.

Regardless of the scenario, the text that follows focuses only on those specific aspects that differ from the P2P case.

Person-to-Legacy Enterprise Application (P2LA)

The P2LA scenario requires interworking with the legacy infrastructure. When the enterprise system does not support the data channel functionality then the DCS provides the interworking functionality between the data channel enabled UE and non-data channel devices and systems on the enterprise premises. Figure A.2.3.1-1 shows the related architecture in which the operator-hosted DCS provides the application layer interworking. It is assumed that the enterprise does not want any changes on its premises and for that reason the DCS is hosted by the operator.

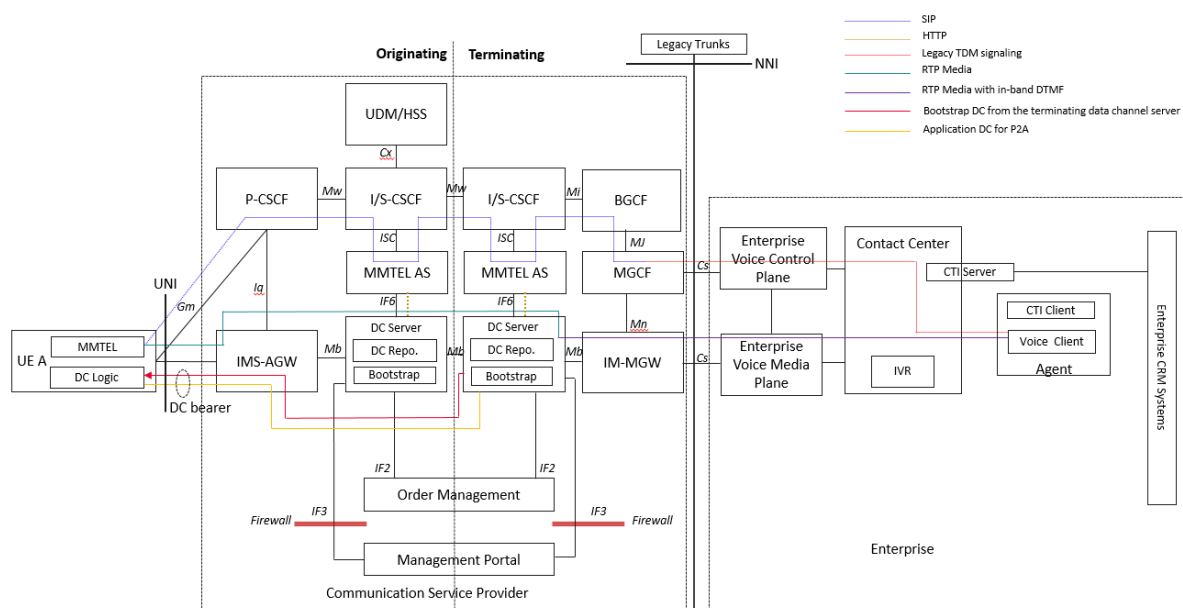

Figure A.2.3.1-1: P2P data channel architecture for legacy enterprise

Note 1: Interfaces IF6, IF2 and IF3 have been described in the P2P section A.2.2.1.

The enterprise needs to publish its enterprise P2A data channel application catalogue on the DCS using the CSP management portal.

The following P2A aspects differ from the P2P case:

1. After receiving a call event notification through DataChannelCallEventNotify operation, the enterprise data channel policy determines that P2A scenario is allowed then the terminating DCS invokes DataChannelCallControl operation to indicate MMTEL AS to establish the bootstrap channel between the calling party and the DCS. Only one bootstrap channel is created for the P2A case.

Note 2: The bootstrap data channel only towards the terminating side is not explicitly defined in 3GPP TS 26.114 [1] but all bootstrap channels can be accepted or rejected independently.

2. The bootstrap data channel is established between calling party UE and the DCS once the SIP negotiation of the bootstrap data channel capability is successful for the P2A case.
3. The basic call signalling and RTP payload are routed from the calling UE to the enterprise legacy voice terminals. The DCS implements the data channel interworking function between data channel capable UE and legacy enterprises devices. Therefore, both the bootstrap and the application data channels are established between the calling UE and the operator-hosted DCS capable of interworking with the enterprise system rather than between the UE and the enterprise system or enterprise device.
4. P2A is anchored to the IMS-AGW using Gm and Mb interfaces specified in 3GPP TS 23.228 [13], but the application data channel terminates on the DCS and does not follow the same path as RTP. Both IMS bearers and the data channel bearers use the same UPF which is selected according to section 6.3.3 of 3GPP TS 23.501 [11].
5. P2A application creates an application data channel based on the enterprise functional requirements. It interacts indirectly with the legacy systems. The application data channel is established between the calling UE and the operator-hosted DCS as per 3GPP TS 26.114 [1] section 6.2.10. It uses 3GPP TS 24.229 [2] section L.2.2.5 specified bearers to carry the enterprise application control and content.

For example, a visible menu application can create its application data channel and interact with the enterprise systems when a user clicks on the submenu items on the application page. The application data channel is released when the call is released.

The application content carried by the application data channel might differ depending on the UE DTMF capability and data channel application access right. There are two implementations:

1. Native UE implementation: data channel application directly invokes terminal DTMF functionality and UE originated RTP payload carries the signal to the enterprise side. In this scenario, no mapping is done between the menu selection and DTMF by the DCS. The only role of the DCS is to serve the visual menu based on the user selection. It is the UE side that synchronizes voice and web content through DTMF and menu id. The application data channel transports only the menu content.
2. Interworking implementation: when the UE does not support the direct generation of DTMF by JavaScript or that is not allowed for some other reasons the mapping or translation between the data channel events and DTMF events is performed by the network side interworking functionality. In this case, the menu item carried by the application data channel is converted to DTMF "telephone-event" by the network function supporting both the data channel and RTP media. No control plane is involved and synchronization is performed by the interworking functionality. RTP payload originated by UE transports no DTMF signals, and the telephone event is multiplexed into RTP payload in the network.

The general service logic is as follows:

1. The calling party is served the visible menu once the call is connected to the Interactive Voice Response (IVR) initial voiceXML script, with the dialler being hidden and only accessible through the home button.
2. DTMF signals are generated natively by UE or data channel media transports the corresponding application event to the interworking function for translation to the in-band DTMF.

3. After receiving the in-band DTMF signals, IVR continues with the voice script and plays the next voice level prompt corresponding to X. At the same time, the DCS enables the next submenu item being displayed to the calling party. The menu presented corresponds to the interactivity design of the voice script and is coded in data channel logic.

Person-to-Data Channel Enterprise Application (P2DA)

P2DA target architecture is defined as one when the enterprise system supports natively the data channel functionality. Then the architecture in Figure A.2.3.2-1 is deployed. It is assumed that in this case the enterprise has upgraded its systems to support the data channel.

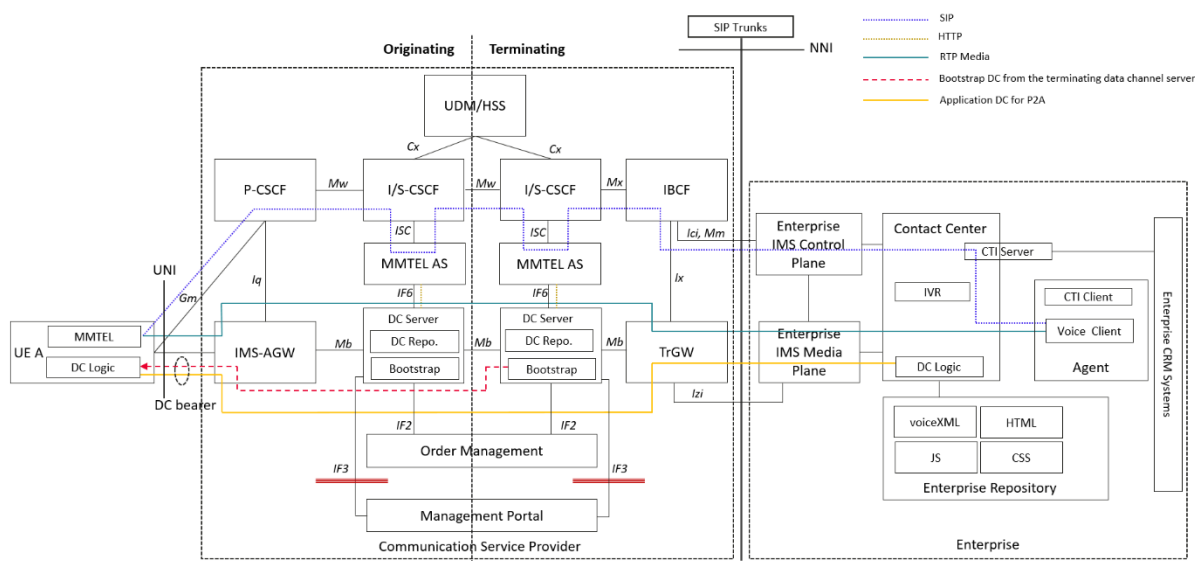

Figure Error! No text of specified style in document.-1: Native P2A data channel architecture.

All configuration, signalling and data channel deployment aspects remain the same with the previous case except.

1. The signalling, RTP payload, and the application data channel are directly terminated on the enterprise system.
2. P2A is anchored to the IMS-AGW using Gm and Mb interfaces specified in 3GPP TS 23.228 [13], and the application follow the same path as RTP payload. Both IMS bearers and the data channel bearers use the same UPF which is selected according to section 6.3.3 of 3GPP TS 23.501 [11].
3. The terminating DCS negotiates the establishment of the bootstrap data channel towards the calling party.

For the visible menu, the enterprise hosted application logic receives the user menu selections and as it plays announcements.

As the call progresses and the user interacts with the system, each user selection causes the next script execution so the next announcement is played and the corresponding visual

menu entry is enabled for display by the calling party by the enterprise application over the application data channel.

User menu selections cause the termination of announcements and the application of the next announcement.

Application-to-Person (A2P)

Application to Person data channel communication is initiated on behalf of brand and seeks to solicit a response from the called party. It differs from the A2P messaging by the real-time connectivity context and the explicitly assumed response, rather than being only for information. The service is used but not limited to running marketing campaigns, political polling, national warnings and other real time notification services. It allows the offline (i.e. Telco) to online (i.e. web) services integration.

The service is operated by the agency representing the brand. It might be internal or external agency but, in its capacity, it delivers both the campaign execution, designs all the interactivity scripts and their multi-channel front end creatives. The creative is any type of digital content used in order to communicate the message and stimulate the response. The existing A2P platforms use SMS, RCS, and voice to deliver the campaign KPIs. The data channel will be added to the campaign catalogue and the related data channel creatives designed specifically by the agency. Finally, once the campaign will be completed, the agency collects the data channel responses and presents those in the required format as a business input into relevant upstream business processes.

A2P Application and its Requirements

A2P data channel service allows the sender to use the data channel to communicate with the recipient, where such communication is not an unsolicited call or content. As such some specific requirements might apply to A2P scenario including:

1. Blocking of A2P marketing traffic during some periods (e.g. weekends, public holidays, after 9 pm).
2. Using of special sender ID (for instance alphanumeric sender ID or fictitious number or random)
3. Having an explicit consent for A2P content delivery. The marketing consent might be acquired through other than the communication service provider channels.

A2P Interconnect and the Ecosystem Organization

A2P typically requires the relation and support from companies providing IMS connectivity aggregation and other services needed for the successful data channel content delivery to the subscribers identified as the object of the communication. Its traffic might enter the voice ecosystem using two routes

1. Service Provider Origination Route: this happens when the communication service provider offers directly either A2P services hosting or A2P traffic routing as part of its enterprise offer and plays the role of aggregator. In that case A2P IMS data traffic might be originated by A2P platform over SIP trunks and routed forward by the hosting service provider based on the B-party address. Some of this traffic might be terminated on the numbering resources belonging to the service provider playing the role of

aggregator. In this case it should be in general assumed that all the traffic can be trusted as all of it was originated by an operator who verified the A2P platform provider as part of know your customer (KYC) processes. A-party A2P numbering resources belong to the operator although those might not be routable.

2. National/International Wholesale Termination Route: this happens when other parties than the communication service providers offer the aggregation services, or when the service providers don't allow the direct A2P traffic origination from its network. In this case the licenced wholesale carrier plays the role of aggregator. All the traffic enters the voice ecosystem over the national or international IMS interconnect from one or more aggregators and terminates on the each of the networks that currently serve the subscriber. In this case it cannot be assumed that the traffic can be trusted since the voice trust chain over interconnect might not be implemented.

The agency representing the brand is assumed to have only one commercial contract for the marketing campaign delivery with the A2P platform authorized by the voice ecosystem to execute mass calling services. Both of the interconnect architectures are shown in Figure A.2.4.2-1.

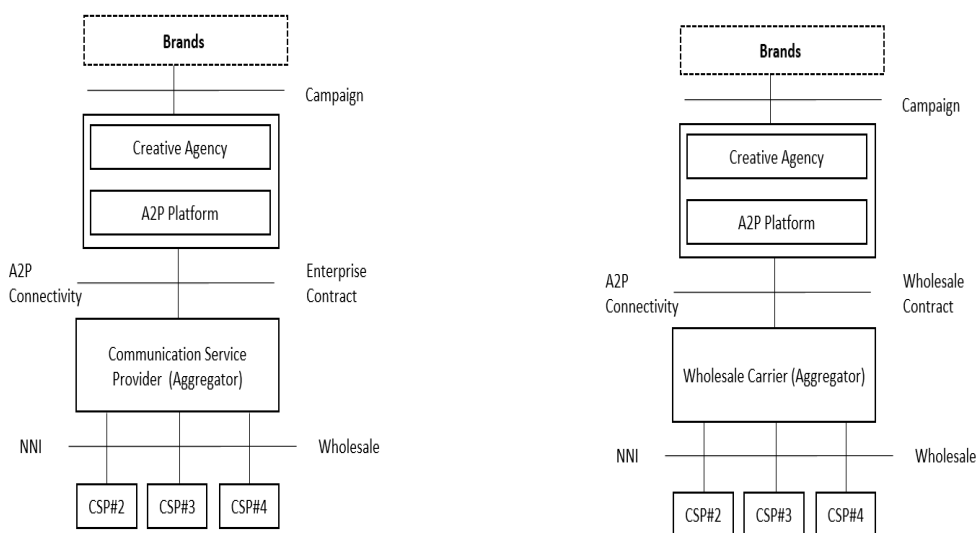

Figure Error! No text of specified style in document.-1: Data Channel A2P connectivity and ecosystem.

In both cases the service should support the data channel termination to subscribers that were ported out/in using the number portability principles.

A2P IMS Data Channel Auto-dialler

The auto dialler functionality is required for the outbound mass campaign delivery. The authorized outgoing data channel A2P traffic is generated by the data channel capable IMS auto dialler which offers the mass calling in one of the two modes

1. Calling in sequence
2. Simultaneous calling

A2P data channel dialler supports the automatic outbound data channel calling using the campaign database as the input for the B-party data. Where applicable it also supports the

collection of data channel responses and their storage in the database. The campaign dashboard is the business back end responsible for the results aggregation, presentation and the delivery to the brand. Where required the transfer to agent might be supported but for the vast majority of campaigns it is assumed that the process will not involve agent transfers and will be fully automated. The data channel auto-dialler traffic might originate from

1. SIP trunks when Contact Centre, PBX, IVR are used by the company running campaigns
2. Smartphones MSISDN when auto-dialler apps are used

The data channel auto dialler might choose to implement HTTP proxy functionality allowing the direct interaction with the brand back end. This is unique and native campaign integration capability offered by data channel stack and IMS APN. The dialler would serve the A2P data channel logic only to UE which support the data channel capability. All other UE would be served only the basic A2P voice logic. Therefore, the auto dialler needs to identify the capability of the terminating party to determine the content type to be served.

A2P Architecture

A2P architecture differs depending on whether the platform responsible for delivering the campaign supports the data channel capability or not. When it does not support the data channel capability then the interworking functionality needs to be deployed similarly as in case of P2A. Therefore, two scenarios are identified:

1. Legacy Application-to-Person (LA2P): defines the scenario where the brand wants to terminate its campaign on the data channel enabled UE but the platform delivering the campaign do not support the data channel stack.
2. Data Channel Application-to-Person (DA2P): defines the scenario where the campaign is delivered to the data channel enabled UE and the platform delivering the campaign supports the data channel.

Legacy Application-to-Person (LA2P)

The agency offering A2P data channel services but without the data channel capability needs to use the operator hosted A2P service logic. This is similar to the P2LA scenario. The A2P service hosting would be offered as part of the A2P enterprise contract. The architecture for legacy application to person when the communication service provider is an aggregator is shown in Figure A.2.4.4.1-1. It is assumed that the communication service provider 2 (CSP#2) is data channel capable and the communication service provider 3 (CSP#3) does not support the data channel. The legacy trunks represent any trunking technology that supports media types defined in GSMA PRD NG.114 [9] but do not support the data channel capability.

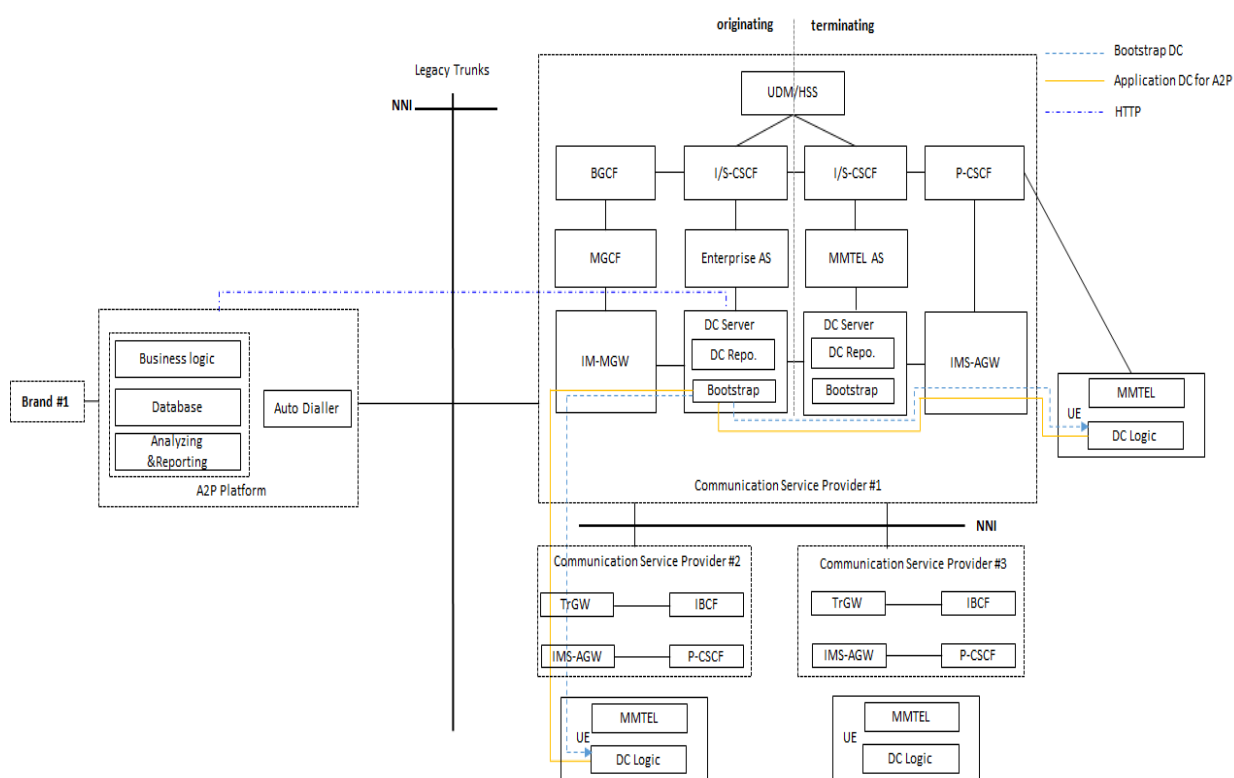

Figure A.2.4.4.1-1: A2P Data channel architecture when the communication service provider plays the role of aggregator.

The enterprise needs to publish its enterprise A2P data channel applications to the DCS using the CSP management portal. It is the operator that hosts the A2P service logic and its front end. The creative needs to engage the called party to respond and the system needs to collect data on per user basis. The data channel allows the direct campaign collection by the agency or the brand web server when such server supports the required storage and backend functionality. Otherwise, the aggregator needs to provide a method to deliver the results to the agency. It might be using CSV files or any other agreed format.

The overall campaign business logic will rank the channels to communicate with each of the subscribers in the database and use their related creatives. A2P campaign will then be executed and for those subscribers where the data channel has been selected as the first communication choice it will be used.

The following A2P aspects differ from the P2P case:

1. The auto-dialler will start placing IMS calls and the call terminates to UE belonging to the communication service provider supporting the data channel
2. If the operator data channel policy allows A2P scenario, then the originating DCS requests Enterprise AS to negotiate the establishment of one bootstrap data channel towards the terminating party.
3. The originating DCS establishes a bootstrap channel with the terminating party once the SDP negotiation of the bootstrap data channel is successful.
4. The terminating party is served the A2P application through the bootstrap data channel. The A2P application is displayed on the terminating party screen.

5. A2P application creates an application data channel. The application data channel is established between the originating DCS and the terminating party. The called party interacts with the A2P application business logic hosted by the aggregator and enters its preference. The interaction might be done directly with the data channel sever where each of interactive responses are collected and latter send to the brand. Alternatively, the brand web page can be served directly and the responses are placed in the brand back end data base set for collecting direct customer feedback. In that case IMS APN can used to interact with the brand dedicated web server and the breakout would be from the IMS network.
6. The campaign results are collected and delivered to the brand.
7. The application data channel uses 3GPP TS 24.229 [2] section U.2.2.5 specified Qos flows to carry the enterprise application control and content. Both IMS Qos flows and the data channel Qos flows use the same UPF which is selected according to 3GPP section 6.3.3 of TS 23.501 [11].
8. When the legacy auto-dialler will terminate IMS calls to networks or subscribers without the data channel support then the A2P content would not be served by the DCS. Only GSMA PRD NG.114 [9] specified IMS media type "Speech" would be served and probably DTMF response mode would be used.

An example A2P scenario would be a campaign run by a consumer goods company to test the attitude towards the brand after a major public image crisis. The following would take place:

1. The consumer goods company orders a campaign to contact 20 million people to verify whether the brand image is tarnished with a specific KPI concerning the reachability.
2. The agency designs creatives including IMS data channel creative.
3. The campaign is designed and the data channel is used to reach consumers.
4. The campaign is executed over all channels including IMS data channel.
5. IMS data channel input is collected.
6. Aggregated results are presented.
7. The brand changes their web page content and platform as result of the feedback. SEO optimisation is also done based on IMS data channel findings.

Data Channel Application to Person

DA2P architecture defines the configuration when A2P platform supports natively the data channel functionality. The platform operator has upgraded its systems to support the data channel functionality and as a result all the interactivity traffic is routed to the A2P platform. All the A2P service logic is implemented and hosted by the A2P platform.

The same aggregator architectures apply and only the one when the service provider is an aggregator is described.

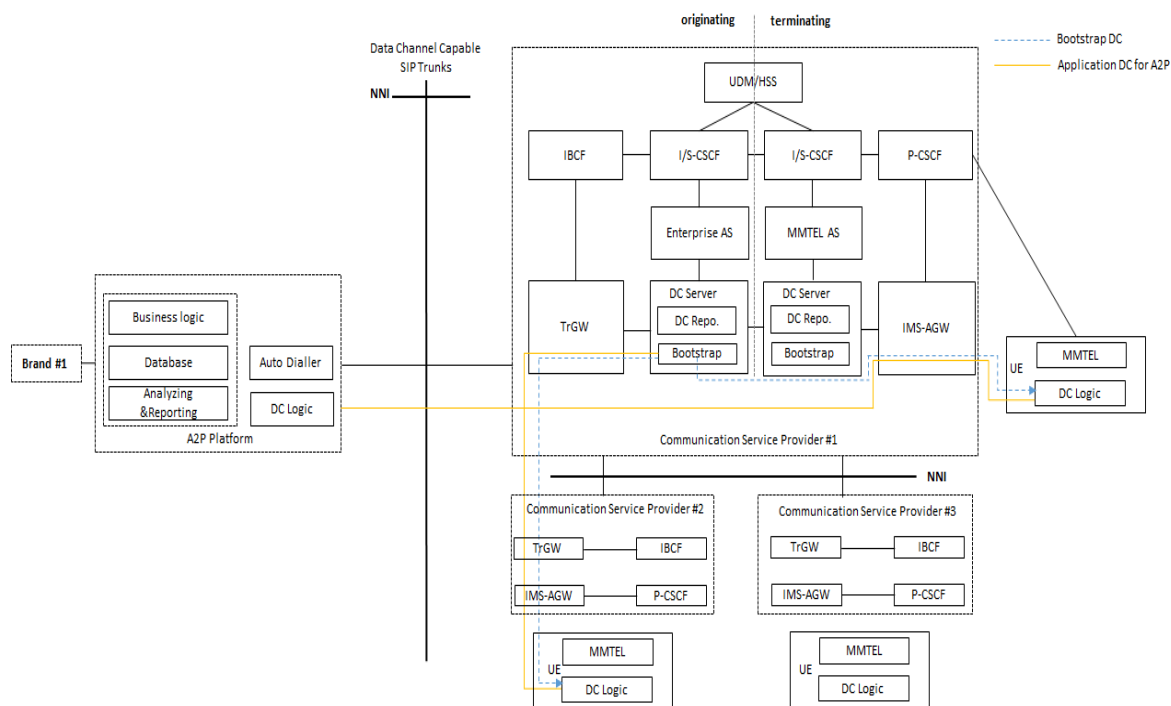

Figure Error! No text of specified style in document.-1: Native A2P data channel architecture with communication service provider as an aggregator.

All configuration, signalling and data channel deployment aspects remain the same with the previous case except.

1. The data channel auto-dialler will start placing IMS calls and the call terminates to UE belonging to the communication service provider supporting the data channel
2. A2P application creates an application data channel. The application data channel is established between the A2P platform and the terminating party.
3. The application follows the same path as the RTP payload. Both IMS Qos flows and the data channel Qos flows use the same UPF which is selected according to 3GPP section 6.3.3 of TS 23.501 [11].
4. The called party interacts with the A2P application business logic hosted by A2P platform. The interaction results might be collected by A2P platform or alternatively the brand web page can be proxied by A2P data channel application. In that case the data channel capable dialler implements HTTP proxy between IMS APN content and the brand web server. This scenario might require the traversal of middle boxes specified in RFC 3234 [14].

When the data channel capable auto-dialler will terminate IMS calls to networks or subscribers without the data channel support then the A2P content would not be served by the DCS. Only GSMA PRD NG.114 [9] specified IMS media type “Speech” would be served and probably DTMF response mode would be used.

B.1 Roaming

IMS data channel roaming might be established using the Standard Bilateral Roaming, Roaming Hubbing, Network Extensions, or Outbound Roaming Solutions. Accordingly, GSMA PRD BA.40 [20], GSMA PRD BA.60 [21], GSMA PRD BA.21 [22] and GSMA PRD BA.23 [23] apply. The data channel roaming agreements are expected to be established

once International Roaming Expert Group (IREG) communication capability and Transferred Account Data Interchange Group (TADIG) call billability is successfully established.

GSMA PRD IR.65 [25] mandates using S8 Home Routing (S8HR) roaming architecture for Evolved Packet System (EPS) roaming and IMS voice and using N9 Home Routing (N9HR) roaming architecture for 5GS roaming and IMS voice. The introduction of the data channel for 5GS does not have an impact on the IMS roaming architecture, and S8HR/N9HR architecture is retained as shown in Figure A.3-1.

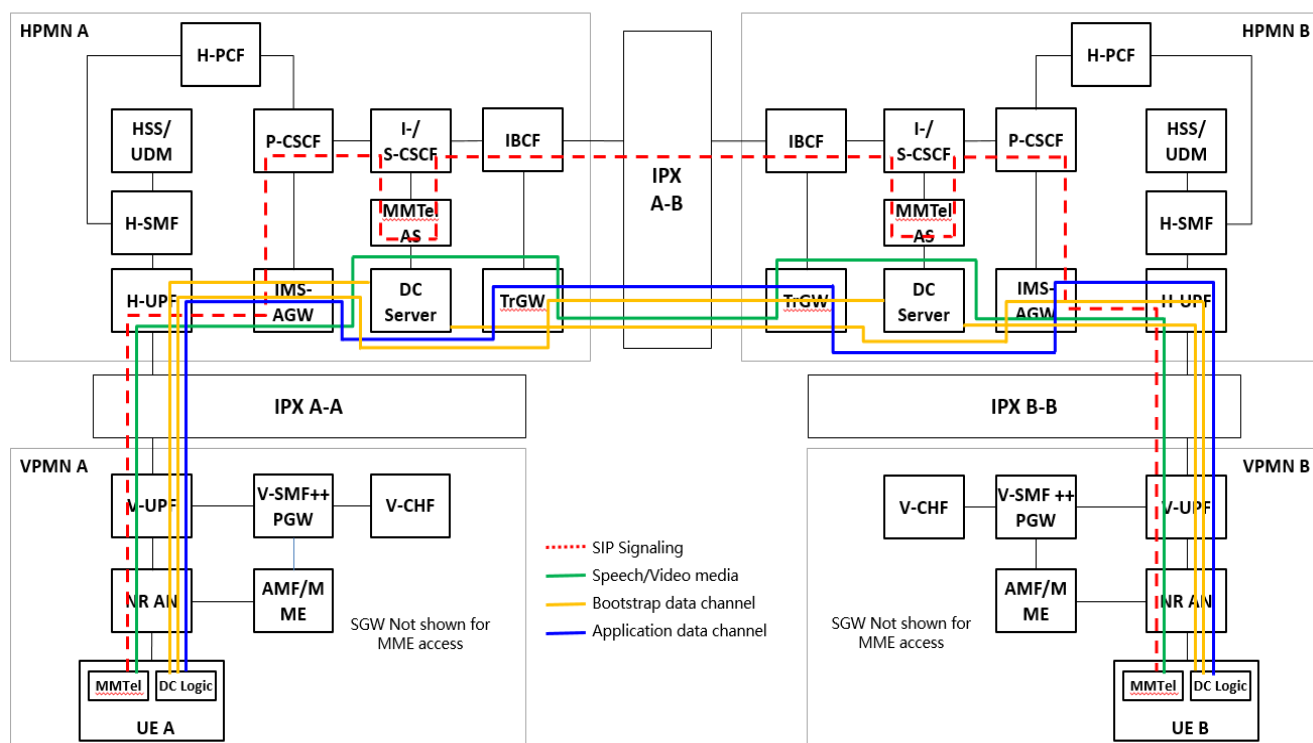

Figure Error! No text of specified style in document.-1: IMS data channel roaming architecture using S8HR/N9HR

While S8HR/N9HR roaming architecture is retained, there are specific data channel requirements on both the Visited Public Mobile Network (VPMN) and the Home Public Mobile Network (HPMN).

Note: It is explicitly assumed that both the VPMN and the HPMN have deployed 5G standalone architecture.

HPMN

The outbound IMS data channel international roaming requires the HPMN to support the following functions:

1. UE IMS data channel profile as per GSMA PRD NG.114 [9].
2. IMS data channel as per 3GPP TS 26.114 [1] and GSMA PRD NG.114 [9], including barring of data channel roaming outside the HPMN as per to 3GPP TS 22.041 [26].

Note: The roaming profile will be applied to the outbound IMS data channel subscriber when available. Otherwise, the standard profile will be used. There are no data channel specific parameters stored in HSS/UDM and communicated to the VPMN.

1. S8HR/N9HR IMS roaming as per GSMA PRD IR.65 [25].
2. QoS flow with 5QI=71, 72, 73, 74, 76 or 9 for data channel media type, as per 3GPP TS 26.114 [1] Annex E.1.
3. To provide lawful interception in VPMN, IMS encryption needs to be disabled for outbound roamers as per section 7.4.7.3 of 3GPP TS 33.127 [27].
4. Data retention as per section 2.14.2 of GSMA PRD IR.65 [25].
5. Collecting charging information per QoS flow within a PDU session when a UE is determined as an out-bound roamer, for Charging Data Record (CDR) generation in the HPMN as per section 5.1.9.1 of 3GPP TS 32.255 [28].
6. GSMA Interoperability and data specifications for wholesale settlement.
7. 5GS Control Plane-Steering of Roaming (CP-SOR) mechanisms as per section 9 of GSMA PRD IR.73 [24]. The HPMN should direct the UE with IMS data channel capability access to a VPMN which support IMS data channel preferentially by update the "Operator Controlled PLMN Selector with Access Technology" list.
8. IREG and TADIG tests must be successfully completed.

VPMN

The inbound IMS data channel international roaming requires the VPMN to support the following functions:

1. S8HR/N9HR IMS roaming as per GSMA PRD IR.65 [25].
2. QoS flow with 5QI=71, 72, 73, 74, 76 or 9 for data channel media type, as per 3GPP TS 26.114 [1] Annex E.1.
3. Lawful interception of data content transferred in both bootstrap data channel(s) and application data channel(s). IMS data channel related to QoS flows should be intercepted for inbound roamers as per section 7.4.7.3 of 3GPP TS 33.127 [27].
4. Data retention as per section 2.14.2 of GSMA PRD IR.65 [25].
5. Charging information collection per QoS flow when UE is determined to be an inbound roamer. CDR generation in the VPMN should comply with section 5.1.9.1 of 3GPP TS 32.255 [28].
6. GSMA Interoperability and data specifications for wholesale settlement.
7. 5GS CP-SOR mechanisms as per GSMA PRD IR.73 [24] section 9.
8. IMS data channel roaming subscribers' activities are subject to data privacy laws in destination countries. Current international roaming agreements address IMS data channel privacy laws.

IPX/Roaming Hub

IMS data channel international roaming requires the IPX/Roaming Hub to support the following functions:

1. Charging information collection per QoS flow when UE is determined to be an inbound roamer. CDR generation in the VPMN should comply with section 5.1.9.1 of 3GPP TS 32.255 [28].
2. QoS flow with 5QI=71, 72, 73, 74, 76 or 9 for data channel media type, as per 3GPP TS 26.114 [1] Annex E.1.

3. Routing of mobile terminated data channel calls to the VPMN as per section 2A.4.3 of GSMA PRD IR.65 [25].

Note 1: The commercial aspects of data channel including the charging and inter-operator tariffs will be described in a dedicated section.

Note 2: GSMA PRD NG.113 [34] section 6.2.2 and Annex A need to be updated. IMS data channel related 5QI should be added into the text.

3GPP TS 33.127 [27] needs to be updated with the details concerning the Lawful Interception of IMS data channel.

GSMA PRD BA.27 [31] needs to be updated. IMS data channel charging and billing should be added into the text.

Both GSMA PRD TD.58 [32] and TD.57 [33] needs to be updated. IMS data channel accounting function related to QCI/5QI should be added into the text.

3GPP TS 22.041 [26] needs to be updated. Section 5.4 which covers barring of roaming should cover also IMS data channel services.

GSMA PRD IR.25 [29] needs to be updated. IREG tests should be defined for data channel originating and terminating calls

GSMA PRD TD.207 [30] needs to be updated. Transferred Account Data Interchange Group (TADIG) tests, based on IREG, should be defined to validate that the roaming partner will bill data channel calls correctly

B.2 DC Control API

The DC Control API provided by the MMTel AS is a programmable interface supporting a set of primitives allowing the 3rd party control of a multimedia telephony service. The communication service provider hosts this API and allows its consumption by all authorized parties who want to develop their own customized business logic.

It is exposed by the MMTel AS and invoked by the 3rd party service consumer (e.g. 3rd party AS/AF) in VoIMS case, or invoked by the Data Channel Server (DCS) in the IMS data channel case. Only the latter case is relevant for this document. The DC Control API is referenced only when its use is necessary to implement the data channel business logic. The DC Control API may be exposed as resource oriented HTTP URI, SOAP XML document, text or binary payload. The DCS consumer of MMTEL API will follow the web pattern and expects to consume the web service-based API (e.g. RESTful oriented or SOAP oriented).

Figure A.4-1 provides the reference model (in service based representation and in reference point representation), with focus on the DC Control API exposed by the MMTel AS, and the service consumer invoking this API.

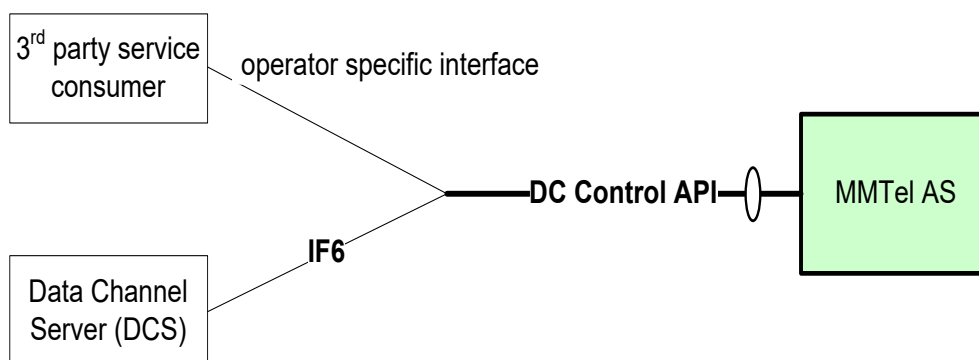

Figure Error! No text of specified style in document.-1: The DC control API and its service consumer.

The Data Channel Server consumes the DC Control API over the control plane IF6 interface (as specified in Annex A). The 3rd party service consumer consumes the DC Control API over an interface defined by the operator. A network capability exposure platform may be placed between the MMTel AS and the 3rd party service consumer. It is recommended to comply to 3GPP TS 23.501 [11] Network Exposure Function (NEF) specification for 5G.

Figure A.4-2 illustrates the DC Control API and its relation to other network functions, e.g. 3GPP functions.

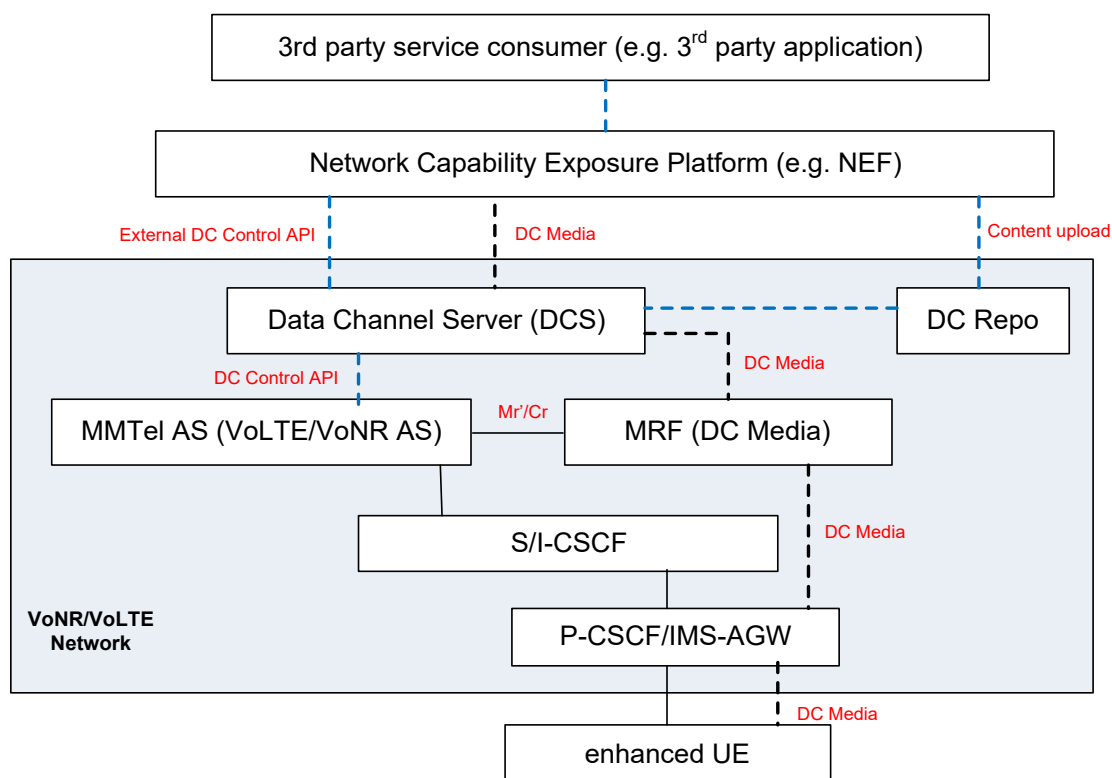

Figure Error! No text of specified style in document.-2: The DC control API and its relationship with other network entities.

The Data Channel Server (DCS) might also expose its own API (i.e. External DC Control API) to the network capability exposure function (e.g. NEF). The Data Channel Server may be collocated with the MMTel AS, or be deployed as a standalone entity.

The DC Control API can be consumed by any authorized Data Channel Servers and the two DCS consumer types are identified:

1. MMTel AS associated: this is direct consumer which belongs to the same administrative domain as MMTel AS, therefore no network capability exposure platform (e.g. NEF) is required. This represents the case where the service provider would also have full control over the content served to the user.
2. Web AS associated: this is indirect consumer which belongs to other than MMTEL administrative domain; therefore, a network capability exposure platform (e.g. NEF) is required. This represents the case where the content served would be partially or totally controlled by other parties than the service provider.

Functionality of DC Control API

The DC Control API should provide the functionality required to manage the life cycle of data channel services. Therefore, it should support the bootstrap and the application data channel management including setup, takedown and accounting.

In detail, the DC Control API shall provide the following functionalities:

IMS call control, including management of IMS call event subscription and notification, and controlling of IMS call.
Management of bootstrap data channels (DC = 0,10,100,110), including bootstrap data channel setup, release, etc.; (via Mr'/Cr for MRF anchoring)
Management of application data channel (DC >= 1000), including application data channel setup, release, etc. (UE to UE or anchoring in MRF for DC media breakout to web server logic in DCS or provided by a 3rd party).

B.3 Interconnect

Annex C National Interconnect

It is expected that all data channel traffic from other operators shall originate and terminate using the IBCF and the TrGW as shown in the IMS Architecture in Figure A.5.1-1.

Originating operator provides Data Channel application - Call Flow example:

1. Voice call is established between two mobile operators
2. Originating operator's Data Channel Server provides Data Channel content and applications
3. Re-invite is initiated between two mobile operators to establish the data channel. If Data Channel can be established the voice call continues, if it cannot the voice call still continues
4. All traffic flows from a signalling perspective use the IBCF to IBCF
5. All traffic flows from a media perspective use the TrGW to TrGW

Terminating operator provides Data Channel application - Call Flow example:

1. Voice call is established between two mobile operators
2. Terminating operators Data Channel Server provides Data Channel content and applications
3. Re-invite is initiated between two mobile operators to establish the data channel. If the data channel can be established the voice call continues, if it cannot the voice call still continues
4. All traffic flows from a signalling perspective use the IBCF to IBCF
5. All traffic flows from a media perspective use the TrGW to TrGW

Below is the proposed Interconnect Architecture for Data Channel traffic. All IMS data channel traffic should use existing IMS SIP Interconnects alongside Voice etc.

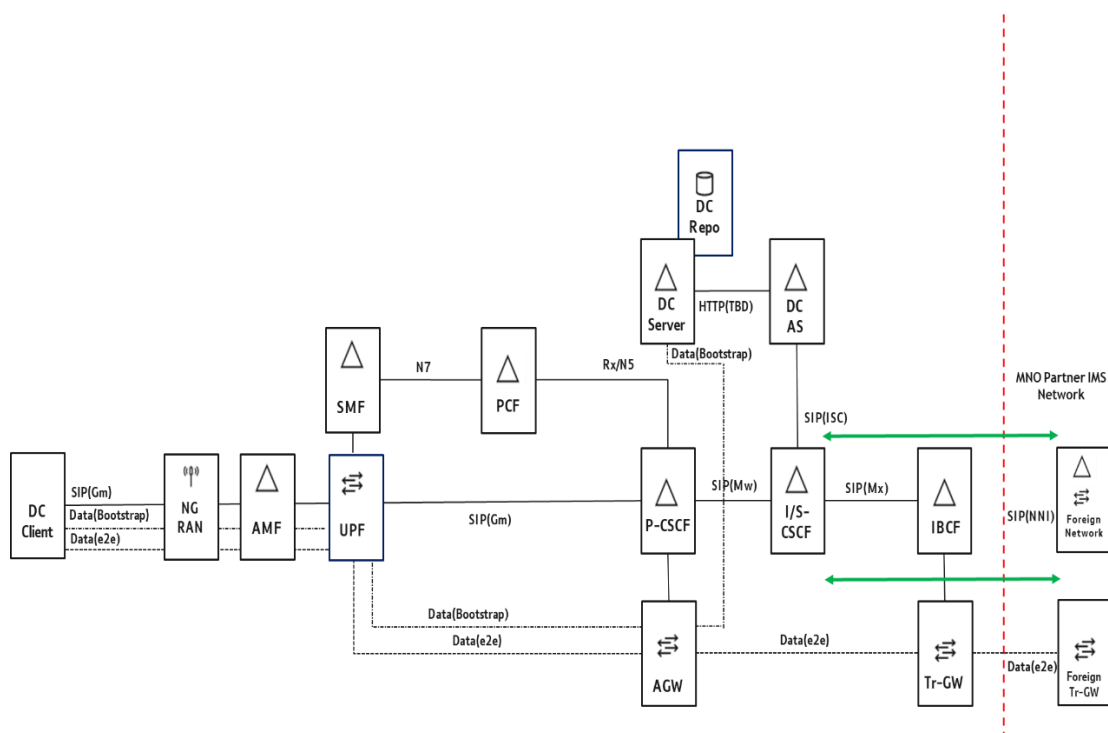

Figure A.5.1-1: Interconnect architecture for data channel

International Interconnect

No specific requirements for international interconnect were identified.

C.1 QoS Framework and Data Channel

3GPP policy and charging control framework for the 5G system is specified in 3GPP TS 23.503 [11]. AF provides information on the packet flow to PCF responsible for policy control in order to support Quality of Service (QoS).

A data channel media description with specific loss or latency requirements should use "a=3gpp-qos-hint" in the SDP offer, as detailed in section 6.2.7.4 of 3GPP TS 26.114 [1]. If

subsequent SDP offers or answers adds data channels with stricter loss or latency requirements that cannot be met by keeping current "a=3gpp-qos-hint" and providing suitable SCTP "a=dcmap" parameters, the existing "a=3gpp-qos-hint" should be modified accordingly. Similarly, if subsequent SDP offers or answers closes (removes) data channels that are known to be the limiting factor for choosing the existing "a=3gpp-qos-hint", a more relaxed "a=3gpp-qos-hint" should be chosen to better fit the remaining data channels.

A bootstrap data channel must be configured as ordered, reliable, with normal SCTP multiplexing priority, and using HTTP as subprotocol (not encapsulating HTTP in TCP), represented by the following, example SDP "a=dcmap" line (SDP "dcmap" attribute is specified in RFC 8864 [4], that defines the data channel parameters for each data channel to be negotiated), which therefore must be present in each data channel media description in an SDP offer from a DCMTSI client in terminal: a=dcmap:0 subprotocol="http".

End-to-end data channel specific parameters "max-retr" and "max-time" specified in RFC 8864 [4] are recommended to use. The "max-retr" parameter indicates that the data channel is partially reliable. The "max-retr" parameter indicates the maximal number of times a user message will be retransmitted. The "max-retr" parameter is optional. The "max-time" parameter indicates that the data channel is partially reliable. A user message will no longer be transmitted or retransmitted after a specified lifetime, given in milliseconds, in the "max-time" parameter. The lifetime starts when providing the user message to the protocol stack. The "max-time" parameter is optional. If the "max-retr" parameter and the "max-time" parameter are not present, then reliable transmission is performed as specified in RFC 4960 [5].

The QoS Class Identifier (QCI) and 5G QoS Identifier (5QI) are used to describe the packet forwarding treatment for different media types. The QCI/5QI for data channel media type can for example be set to 71, 72, 73, 74, 76 or 9 as specified in section E.1 of TS 26.114 [1].

Annex D Device Support of Data Channel

3GPP TS 23.501 [11] provides the definition of "voice centric" and "data centric" UE's for 5GS. Accordingly, the terms are applied to the data channel capable UE with the following meaning

1. A UE set to "**voice centric**" for 5GS shall always try to ensure that Voice service is possible. A voice centric 5GC capable and EPC capable UE unable to obtain voice service in 5GS shall not select a cell connected only to 5GC. By disabling capabilities to access 5GS, the UE re-selects to E-UTRAN connected to EPC first (if available). When the UE selects E-UTRAN connected to EPC, the UE performs Voice Domain Selection procedures as defined in TS 23.221 [19].
2. A UE set to "**data centric**" for 5GS does not need to perform any reselection if voice services cannot be obtained.

This section describes UE architecture with the focus on those two categories of mobile devices.

D.1 Voice Centric UE

The functional components of a UE including an MTSI client in terminal using 3GPP access are defined by Figure 4.2 in 3GPP TS 26.114 [1] which constitutes the reference architecture. See Figure B.1-1.

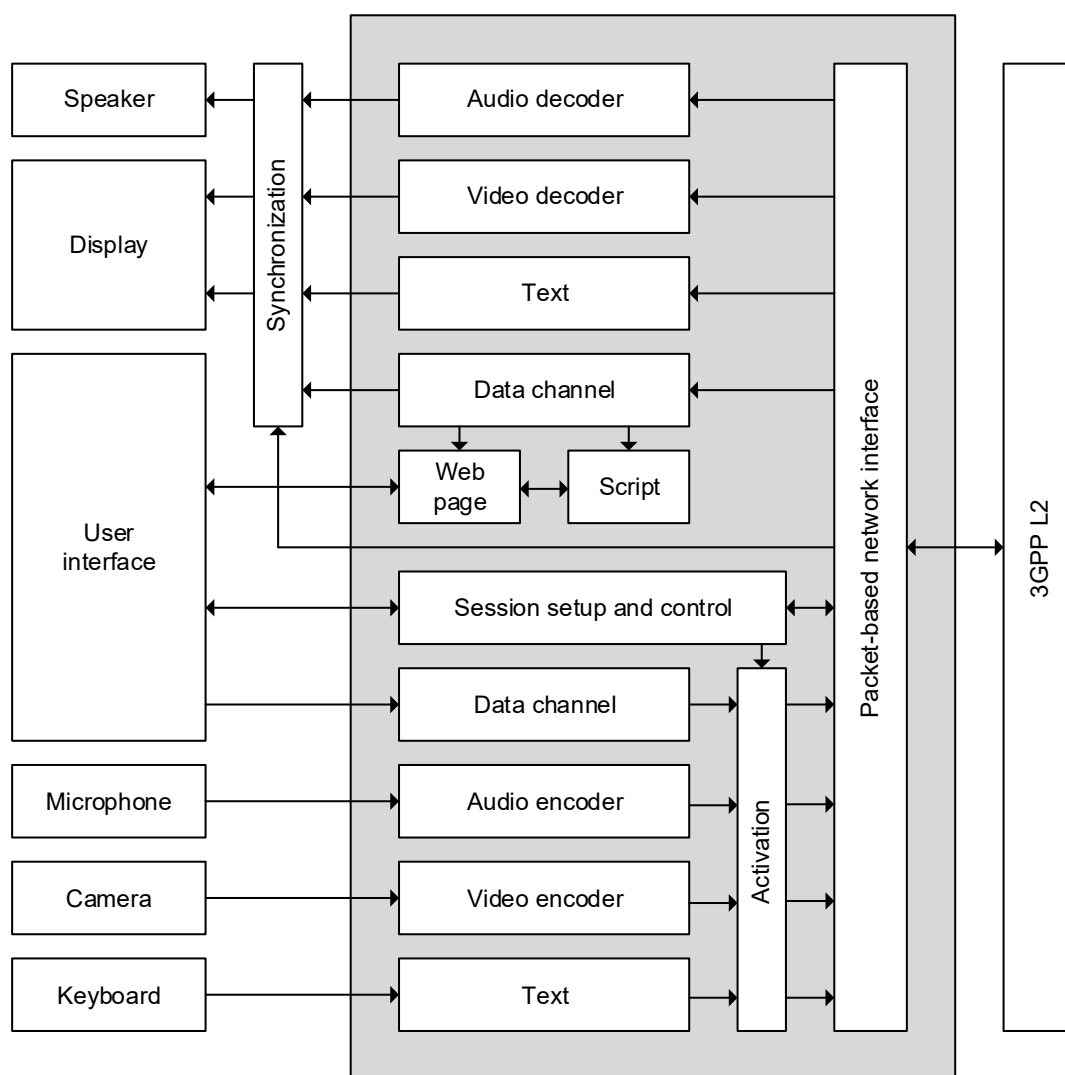

Figure B.1-1: Functional components of a terminal including an MTSI client in terminal using 3GPP access.

The voice centric UE consists of three principal layers which are described in this section:

1. The hardware representing the physical components of UE usually manufactured according to the brand specifications.
2. The software implementing the IMS client business logic specified in 3GPP TS 23.228 [13] and TS 26.114 [1].
3. The human machine interface (HMI) or user interface (UI) allowing to interact with the software and control the hardware.

Hardware Architecture of Voice Centric UE

The IMS data channel has no impact on the voice centric UE hardware architecture. Both 3GPP TS 26.114 [1] defined Multimedia Telephony Service for IMS (MTSI) client in terminal

and "DCMTSI client in terminal" denoting IMS data channel capable MTSI use the same hardware architecture.

Software Architecture of Voice Centric UE

The general voice centric UE software architecture without IMS data channel capability is shown in Figure B.1.2-1.

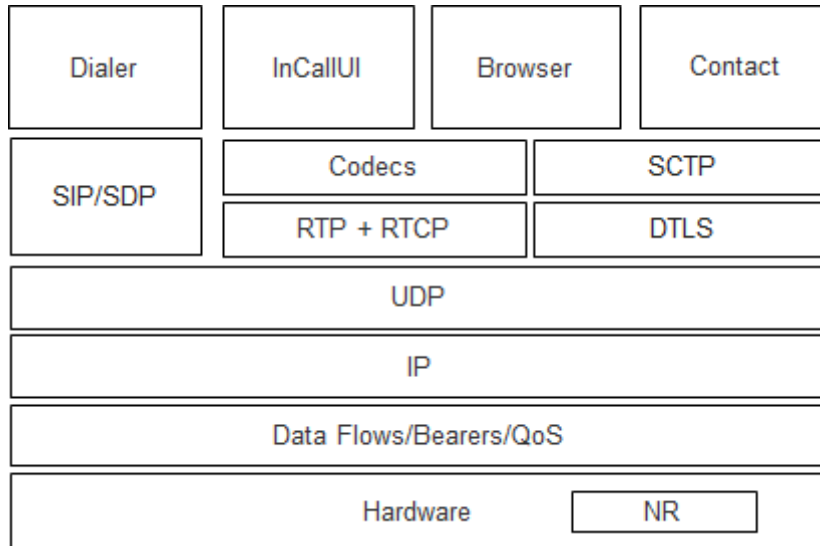

Figure B.1.2-1: Voice centric UE software architecture without IMS data channel capability

The general voice centric UE software architecture with IMS data channel capability is shown in Figure B.1.2-2.

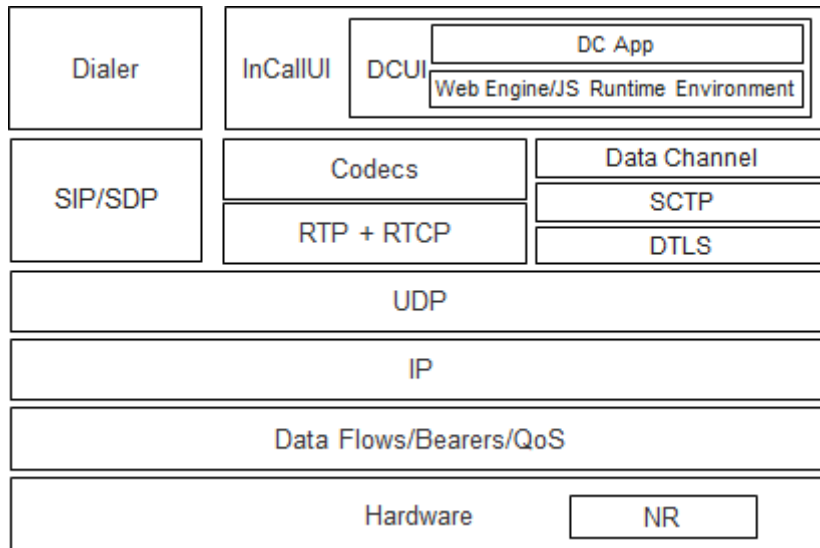

Figure B.1.2-2: Voice centric UE software architecture with IMS data channel capability

The differences between Figure B.1.2-1 and Figure B.1.2-2 are:

1. The Data Flows/Bearers/QoS layer supports 5G QoS Identifier (5QI) packet forwarding treatment specified in Annex E1 of 3GPP TS 26.114 [1].
2. The SIP protocol stack supports IMS data channel media offer and answer procedure specified in section 6.2.10 of 3GPP TS 26.114 [1].
3. The DTLS protocol stack initiates the DTLS session between the UE and the IMS network, which is used by the SCTP protocol stack to ensure the security of data transport, as specified in IETF RFC 8261 [38].
4. The SCTP protocol stack initiates the transport layer connection between the UE and IMS network as specified in IETF RFC 4960 [5]. It also provides interfaces to send and receive data through IMS data channel(s).
5. The Data channel component integrates the SCTP/DTLS protocol stacks and provides JavaScript APIs to initiate IMS data channel(s) and uses them for sending and receiving data.
6. InCallUI system application manages the UE display during MMTel calls. When enhanced to support the IMS data channel, it is referred to as DCUI for short. The DCUI name, regardless of implementation, stands for all the UE functional component(s) needed to support the IMS data channel as defined in 3GPP TS 26.114 [1]. Its front end represents the IMS data channel user interface and is responsible for its content display and user interactivity as described in section 4.1.3. It might do so in OS vendor specific ways. For instance, in the Android ecosystem, the native Web engine WebView might be used to render HTML content and execute JavaScript code. Other OEMs can provide their own mechanisms. DCUI back end network logic uses other system services to interact with the Data Channel Server (DCS) to receive content over the bootstrap channel(s) or establish the application data channel(s).

Note: IMS data channel interactivity is based on JavaScript and its Runtime Environment. It also uses W3C defined WebRTC1.0 defined data channel API. At this time, it is still unknown whether single WebRTC1.0 JavaScript Runtime Environment can support both the W3C defined data channel and 3GPP TS 26.114 [1] defined IMS data channel.

Data Channel User Interface of Voice Centric UE

The IMS Voice User Interface is the graphical user interface (GUI) supporting both the device control and media components (i.e. the transfer of GSMA PRD IR.92 [8] compliant and GSMA PRD IR.94 [18] compliant media between devices) and is enabled by specific hardware layer components. The media component is developed separately from the control components. The former is based on GSMA functional requirements, and the latter is OEM specific. Both are implemented based on the 3GPP defined DCMTSI client in terminal reference architecture.

The UE enabled with the IMS data channel capability enhances interactivity defined as the spectrum of activities that two people, or person and a brand can execute on the communication object while using DCMTSI client. The legacy UE limits those activities to communication content that can be effectively conveyed by GSMA PRD IR.92 [8] and IR.94 [18] defined “speech” or “video”. This passive content is limited to three types of content:

1. Referential: describing the facts.
2. Expressive: expressing moods, emotions or feeling.

3. Conative: issuing call for action or purpose but not executing the action itself. This content transfer is enabled through the use of natively provided dialler. While it supports the voice and video establishment it does not support any active content capability. It does not allow to operate on the objects of IMS communication since the MTSI client architecture does not provide the support for active content. Neither does the back end support the web content integration into the IMS architecture resulting in the fragmented user experience and forcing subscribers to move between the MUI (multimedia user interface) and GUI when the access to active content services is needed.

The dialler itself represents one of the most stable and immutable components of MTSI client resulting in the monomorphic UI. It is ossified and has not changed since the invention of mobile touch screen devices. The action oriented communication evolution has taken place outside the dialler prior to IMS data channel development and within the browser or standalone applications.

The IMS data channel capable UE extends the IMS session interactivity spectrum by enabling the active content. The DCUI (or enhanced InCallUI) component supports the insertion of active web GUI into the IMS call allowing users to act on the remote objects of communications (i.e. forms, games, devices, industrial equipment, etc.).

The IMS data channel enables UI polymorphism by the means of InCallUI as shown below on Figure B.1.3-1. In other words, the dialler form and function are not limited in any way.

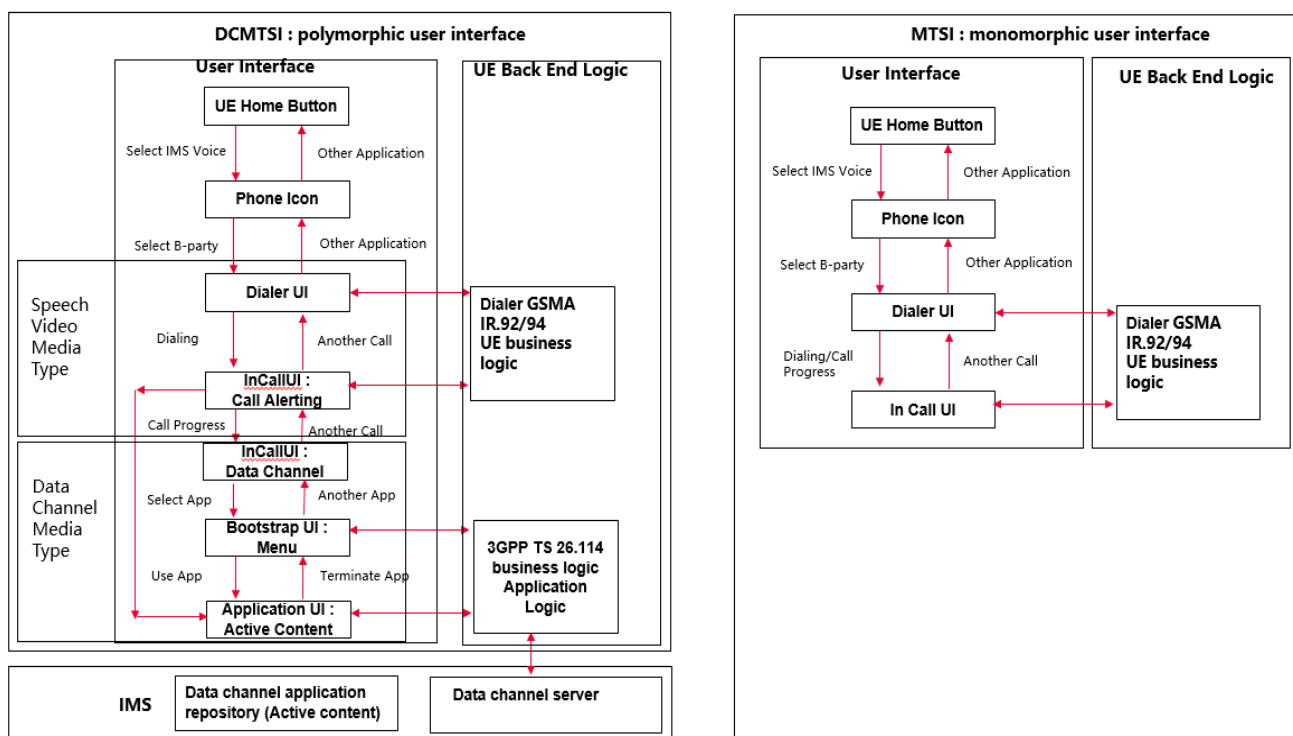

Figure B.1.3-1: IMS data channel user interface components

The resulting new action oriented UI semantics is explained in Table B.1.3-1.

IMS Data channel UI structure	
Service Access	Phone Icon

URL Entry User Interface	Dial pad
Mid-session User Interface	InCallUI with Active HTML/JavaScript content consumption and interaction within browser engine
Pointer	Device or Hand
Business Logic	Action oriented multimedia communications
DCMTSI software implementation	“Browsified” or “Active” Dialler
Session Attribute Icon	GSMA defined HD Logo or OEM defined VoLTE symbol

Table B.1.3-1: IMS data channel UI semantics

The enhanced interactivity results from two complementary technical mechanisms:

1. OEM controlled and converged front end user interface enabled by the native dialler to browser integration. It is based on 3GPP DCMTSI architecture.
2. 3GPP standardized back end IMS to web business logic integration enabled by the Data Channel Server (DCS) insertion into the IMS processing.

Regardless how the DCMTSI client in terminal is implemented, the user is presented with a single context that supports now both the legacy MTSI client applications and the additional applications made possible by the IMS data channel media components. The end result is the enhanced interactivity seen through the optic of the dialler.

Note: DCMTSI client in terminal can be implemented by either embedding the browser into the dialler making monolithic application or by having both applications separate and cooperating through the OEM provided mechanisms. Either option have same goal to present the appropriate content for convenient

D.2 Data Centric UE

The differences between the voice centric UE and the data centric UE lie only in their network selection policy. The data centric UE architecture supporting IMS data channel has no difference with that of the voice centric UE. Please see section B.1 of GSMA NG.129 for further details.

Annex E Relationship with Enriched Calling

The current version of GSMA PRD RCC.20 [7] defines the following Enriched Calling services:

1. Pre-call: this service has two realizations, MMTEL Call Composer which uses already defined SIP headers in the SIP INVITE request, and MSRP Call Composer which uses an MSRP session.
2. In-call Shared Map: this in-call service is currently realized by using an MSRP session to carry the service-related messages.
3. In-call Shared Sketch: this in-call service is currently realized by using an MSRP session to carry the service-related messages.
4. In-call chat, in-call file transfer and in-call location sharing, realized by using RCS messaging.
5. Post-call: this service is realized via an RCS chat message carrying an audio or text message sent when the recipient misses or does not answer the call.

The in-call services are static, and new services cannot be easily added. One example is providing a visual interactive menu within a call. To standardize visual interactive menu in the same way as in the past would require months of standardization work, months of deployment and testing and would in the end limit the types of menus that can be used.

New services based on IMS data channel can be defined and deployed at a much faster pace, once the data channel functionality is present in the devices and in the operator's network. Use of the IMS data channel has been profiled in the GSMA PRDs for voice and video calling: IR.92 [8] and NG.114 [9].

The Enriched Calling GSMA PRD RCC.20 [7] builds on the voice and video calling PRDs, so within the Enriched Calling umbrella, once the use of the IMS data channel is profiled in PRD RCC.20 (e.g. by referencing the latest GSMA PRD NG.114/IR.92 specs), a more flexible and future proof way to provide new innovative services within a voice or video call will be possible.

Annex F Requirements Summary

This section describes the key requirements that must be satisfied to deploy data channel services both in HPMN and VPMN.

F.1 Network Requirements

In order to support IMS Data Channel in 5G, the network must support the functionalities listed in Table D.1-1.

Network Systems	Requirements
5G Radio Access Network	Shall have the capability to support IMS service, as specified in 3GPP 38.300 [50], 3GPP TS 23.501 [11], 3GPP TS 23.502 [16], etc.
5G Core Network	Shall have the capability to support IMS service, as specified in 3GPP TS23.501 [11], 3GPP TS 23.502 [16], etc. All P-CSCFs in the operator's PLMN shall have the same support for IMS data channel.
IMS Core	Shall have the capability to support IMS data channel, non-exclusively including: <ul style="list-style-type: none"> - Support the inclusion of sip.app-subtype media feature tag to indicate the IMS Data Channel capability, as specified in 3GPP TS 26.114 [1], 3GPP TS 24.229 [2], GSMA PRD IR.92 [8] and GSMA PRD NG.114 [9]. - Support for "data" media component setup for IMS data channel, as specified in 3GPP TS 26.114 [1].
Data Channel Server	Shall have the capability to support IMS data channel, as specified in 3GPP TS 26.114 [1]. Furthermore, the Data Channel Server shall also support the following functionalities: <ul style="list-style-type: none"> - DCS should interwork with MMTel AS and consume its DC Control API, as specified in section 3.4.5. - DCS should provide External DC Control API to (external) third party service platform, to develop, deploy and control the data channel services, as specified in section 3.4.5.

Table D.1-1: Network requirements for supporting IMS data channel

F.2 Requirements for Voice-centric UE

In addition to the requirements specified in GSMA PRD NG.114 [9], the UE should fulfil the functional requirements listed below in order to support IMS data channel in 5G:

1. Support including the application feature tag "+sip.app-subtype" with a value of "webrtc-datachannel" in the Contact header in the SIP Register request as specified in 3GPP TS 26.114 [1].
2. Support SDP based data channel negotiation and creation procedures including SDP offer/answer mechanism and interaction based on SCTP/DTLS as specified in 3GPP TS 26.114 [1] and IETF RFC 8864 [4].
3. Support the bootstrap data channels where the stream ID is less than 1000, including the defined data channel stream IDs 0, 10, 100 and 110, and mechanism of accepting

desired data channel by removing "a=dcmap" and "a=dcsa" lines of others from the SDP answer, as specified in 3GPP TS 26.114 [1].

4. Support the application data channels where the stream ID is greater than or equal to 1000 as specified in 3GPP TS 26.114 [1].
5. Support exchanging data in the data channel via SCTP and DTLS protocols as specified in 3GPP TS 26.114 [1].
6. Support exchanging data in the bootstrap data channel via HTTP over SCTP/DTLS as specified in 3GPP TS 26.114 [1].
7. Support rendering and displaying the HTML 5 web page transferred in the data channel from the network.
8. Support parsing and executing JavaScripts transferred in the data channel from the network, and support the application data exchange via the script as specified in 3GPP TS 26.114 [1].
9. Support creating and maintaining multiple data channels simultaneously, each of which may contain multiple data streams with the aggregate of all defined data channels keeping within the negotiated bandwidth limit, as specified in 3GPP TS 26.114 [1].
10. Support W3C WebRTC1.0 data channel API specification, specifically providing access to RTCPeerConnection object and RTCDataChannel object, and their data channel parameters and the call-backs.
11. Support 5G QoS Identifier (5QI) packet forwarding treatment as specified in section E1 of 3GPP TS 26.114 [1].
12. Support JavaScript mechanism (Promise or other) whereby the application specific loss and latency requirements using a=3gpp-qos-hint are synchronized between the JavaScript business logic and the native dialler which is responsible for SDP handling.
13. Support for web content delivery and routing over IMS well-known DNN.

At a high level, enabling interactive calling on a 5G smartphone requires

14. IMS client/stack updates as per 3GPP TS 26.114 [1] and GSMA PRD NG.114 [9]
15. a Phone dialer application with an integrated browser component, and
16. a web page/app developer environment with additional web page/JavaScript APIs to device specific assets.

See Figure D.2-1.

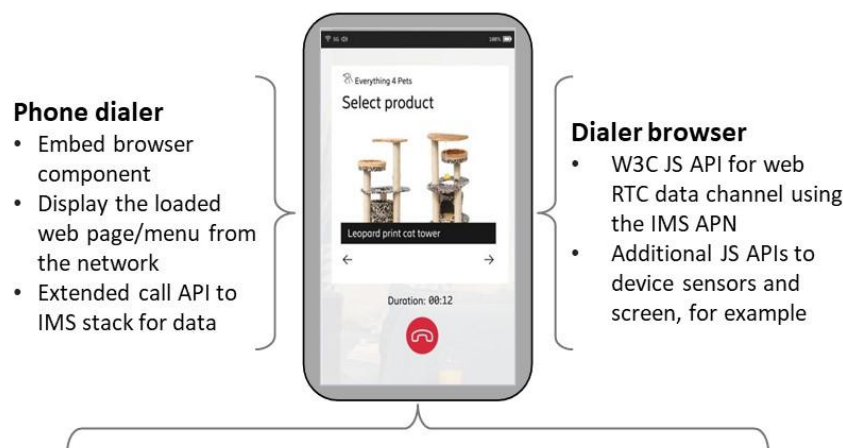

Figure Error! No text of specified style in document.-1: Enabling interactive calling on a 5G smartphone.

F.3 Security and Privacy

The air interface supports the encryption and integrity protection according to 3GPP TS 33.501 [11] section 5.2.2 and 5.2.3.

IMS core network functional elements provide the security methods defined in TS 33.203 [44] and TS 33.210 [48]. IMS media plane security for RTP and MSRP based media is specified in 3GPP TS 33.328 [45].

The data channels are using SCTP over DTLS [38], as specified for WebRTC data channels [43]. The encapsulation of SCTP over DTLS provides WebRTC data channel confidentiality, source authentication and integrity-protected transfers [43].

IMS data channel confidentiality ensures that the data channel media objects and resources are protected from unauthorized viewing or access. It is assured by the bootstrap and application data channels encryption. DTLS [51] layer provides the required encryption service which is applied on the end to end basis between the A-party and B-party.

IMS data channel integrity ensures that the data channel media objects and resources are reliable, protected from unauthorized changes and correct. DTLS [51] layer provides the required integrity service which is applied on the end to end basis between the A-party and B-party. Additionally, 3GPP TS 33.501 [11] defines the integrity protection of the user plane between the device and the gNB for 5GS.

IMS data channel availability ensures that the authorized users have access to the data channel resources when needed. The data channel availability is supported by geo-redundancy, link/path redundancy, and high availability configuration of critical nodes.

Note: Availability related features are not standardized by 3GPP or profiled by GSMA.

IMS data channel uses 3GPP TS 33.203 [44] and TS 33.210 [48] defined authorisation and authentication mechanisms. No specific registration mechanism is required for the data channel service.

IMS core network does not define the reference point that would allow for data channel capable UE to communicate with the external web servers to download HTML content. Therefore, the currently proposed architecture uses 3GPP 23.228 [13] defined MRF to provide the gateway or IMS internet break out capability. MRF transforms 3GPP TS 23.002 [49] defined Mb interface located within IMS trust domain and carrying data channel media to web interface which can be externalized over an exposure interface via an exposure gateway or via 3GPP defined NEF/N33 interface towards AF representing HTTP server and located in another trust domain. In that case, it is recommended that DCS acts as HTTP gateway towards the external web resources. DCS must be placed behind firewall.

When the data channel application needs to access the 3rd party web content over IMS APN, then the DCS might need to support web URL resolution, security screening or redirection.

DC control API exposes DCS call control capabilities via an exposure gateway or through N33 interface specified in 3GPP TS 23.501 [11] and as such it would support authentication and authorization of API requests from AF, identification of the API consumer including access control list and API firewall functionality. The security features and mechanisms for secure access Network Exposure Function Northbound APIs is specified in section 7.2 of 3GPP TS 29.522 [47].

The data channel applications uploaded by the user or some other authorized party might have to be certified prior to being made available when the contractual terms and conditions demand such certification. General, developer ecosystem security principles might need to be developed for IMS data channel market. The data application repository shall be secured by the CSP or the other party responsible for its operations.

IMS core network enabled with the WebRTC data channel capability ensures that both VoNR and data channel information is kept secret to the extent required by the regulation. The privacy requirement that the data channel subscriber have some control over how the information is collected, used, or disclosed is supported by the technical means and ensured by the national regulations like GDPR in Europe.

Note: GSMA FS.38 [46] (e.g. section 2.6) needs to support IMS data channel media, therefore a CR will be issued later for this. A complete study of IMS data channel security needs to be undertaken by GSMA FASG working group.

F.4 Commercial Principles

The GSMA WSOLU concluded that the commercial principles currently defined for the IMS APN are sufficient to deploy IMS data channel in roaming scenarios, therefore what is already written in GSMA BA.27 [31] will apply and no extensions are needed at this time. The group concluded that the interconnection scenario will require further study to confirm that the existing commercial principles for interconnection apply.

F.5 Regulatory

The Lawful interception of bootstrap data channel(s) and application data channel(s) applies to VPMN and HPMN. The regulatory requirement mandates that QoS flows should be intercepted as per section 7.4.7.2 of 3GPP TS 33.127 [27]. The bootstrap and end-to-end data channels must be anchored in the IMS core network to support HPMN lawful interception requirement.

GSMA IR.65 [25] mandates the use of Home Routing architecture to support IMS services roaming. Thus, the HPMN must support the requirements of the VPMN. This means that the HPMN will, on a per VPMN basis, decide whether to use or not the encryption.

The Home Routing architecture is used by all services but the emergency service which uses the Local Breakout but has no specific data channel regulatory requirements.

Data retention is as per section 2.14.2 of GSMA IR.65 [25].

F.6 Contractual Aspects

The current contractual arrangements would not need to change to support 5G Data Channel, except an update to the Commercial Launch Letter.

Annex G Data Channel Application Market Place

This section describes the data channel from the perspective of application developer and the programming ecosystem rather than Communications Services Provider (CSP). It gives the developers a summary introduction to the key data channel concepts and explains how to develop the data channel applications. The data channel application development does not differ from the enterprise web application development. Both are enabled by the three core component technologies:

1. Hypertext Markup Language (HTML) describing the content to be displayed
2. Cascading Style Sheets (CSS) specifying the style and the layout
3. JavaScript programming language allowing client side interactivity without the page reloads (permitting also the implementation of the server side logic along the other options like PHP, Java)

Those technologies have their own existing web marketplace and developed ecosystems. As such therefore the data channel marketplace will become a part of general web ecosystem. According to 2020 stack overflow survey (<https://insights.stackoverflow.com/survey/2020#overview>) JavaScript with HTML are the most popular among developers in the Programming, Scripting, and Markup Languages category with jQuery, React.js, Angular taking top three places in Web Frameworks. For the second year in a row, Node.js takes the top spot as cross-platform, back-end JavaScript runtime environment, as it was used by half of the respondents. Not only is the programming framework used by the data channel very popular amongst the developers but also the toolchain is mature and well developed.

The data channel ecosystem foundation exists and the Communication Service Providers need only to develop and promote the IMS related concept to the existing web community together with the innovation and the economic opportunities offered by 5G to the developers. Those activities are expected to fuel the ecosystem growth and attract the critical mass of developers so a community might form. It is important to acknowledge the benefits offered by the existing W3C WebRTC data channel, since it brings not only the mature standard but also the existing community of developers who can immediately develop IMS data channel applications.

The telco industry should ensure that the data channel developers learning process is not intimidating for newcomers and becomes exciting with results as quickly testable as with HTML or JavaScript.

The data channel developer manifesto while not yet available should be formulated and governed on the democratization of telco knowledge and cost free entry for developers.

G.1 The Data Channel App Developers

The developer is any individual interested to learn, experiment, develop the data channel applications for fun or commercial purpose. Any such individual or company contribute to the data channel software repository. She or he should have the access to the basic data channel developer framework at no cost.

The developer environment contains the following elements:

1. JavaScript APIs
2. Run time emulation environment
3. Data channel system libraries, when those are not natively provided by the emulator
4. Developer guide with some examples
5. Developer network to build the ecosystem

The following skills are required to become the data channel developer:

1. HTML/JavaScript/CSS browser (i.e. using JavaScript, jQuery, Angular™, or Vue.js) programming experience
2. General Integrated Development Environment (IDE) experience (i.e. Microsoft™ Visual Studio Code, Netbeans™)
3. Application server programming (i.e. using Node.js, Apache Tomcat™, etc.), deployment and packaging skills
4. Database programming experience (like MongoDB™)
5. General web and mobile application development experience

In addition to those technical requirements, the data channel marketplace may put security checks in place e.g.

1. validating the security of the software (e.g. code review)
2. validating the used libraries, modules and tools for security impacts and update requirements
3. performing security checks on the developers or related companies

Based on those checks, the data channel marketplace may then sign or otherwise confirm the trustworthiness of the developed software.

Parties offering the commercial data channel applications are also developers but those are assumed to be incorporated in some form. The telco ecosystem players including the communications service providers, enterprises, network equipment providers and terminal vendors can become data channel developers. The same applies to the enterprises and vertical markets in general.

Developers develop the data channel applications but also depending on the commercial agreements might be involved in the operational aspects of their application. They are the owners of the application and its IPR unless some commercial agreement is agreed and those are passed upon other parties like re-sellers or app stores.

The application launch into the production environment is determined by the Terms and Conditions (T&C) applied between the parties.

The data channel application ecosystem (as part of web ecosystem) growth can be further facilitated either through some open source initiatives or through MoU type actions encouraged by the carrier voice ecosystem players. In order to build, sustain and grow the data channel ecosystem, full toolchains and reference systems should be made available. The existing WebRTC developer toolset needs to be complemented with the elements that support at no or at low cost the testing, validation and launch of IMS data channel applications, which differ from the native WebRTC applications by using dedicated IMS media components “Speech” and “Video”

Data Channel Application Exchange

The data channel applications should become a software artefact traded either over the counter, AppStore/Aggregator traded or open sourced. Together with the software different rights will be exchanged.

1. **Over-the-counter** or tender based data channel apps are supply contracts that will be privately negotiated directly between the two parties, without going through an exchange or other intermediary. Effectively those will be bespoke solutions sourced through call to tender. Those might apply for specialized vertical use cases or to A2P/P2A.
2. **App store/ aggregator** based data channel apps are standard supply contracts that will be traded via specialized data channel intermediaries which might assume additional responsibilities as the clearing houses and the certification authorities. Those will be globally traded data channel components. Those might apply to general consumer use cases or P2P.
3. **Open source** are the data channel applications that will be made available with no commercial terms attached. Those might be made available to users for their own local use.

Each data channel application will have some commercial model and those might vary from being free to being available at some cost. Therefore, the developer and the service provider or enterprise using the data channel application will have to agree on the method to finance the data channel app and its life-cycle. It might be financed directly through the usage, subscriber contract inclusion or indirectly by some methods like AdTech.

G.2 Data Channel Application Rights Trading

The data channel market will be trading the source code rather than binaries given the nature of HTML/CSS/JavaScript. Once the deployment package is released to the service provider its code becomes open.

Therefore, it is required that where applicable IPR rights of developers are protected and at the same time the counter parties can meet its business objectives. Therefore, a licensing framework needs to be developed which will allow the ecosystem to exist. Different right types might be traded accordingly with the data channel services including:

1. Right to use
2. Right to modify
3. Right to own
4. Right to transfer

Data Channel Software Deployment Process

The data channel application software development model and the system architecture is decided by the developer or agreed with the counterparty. Their objective is to deliver functionally valuable and secure applications that are used frequently, not the process compliance that is void of consumer value. The web development principles should apply to the data channel.

Note 1: 3GPP TS 26.114 [1] specifies JavaScript as the only programming language for the client side. That and other related 3GPP standards are silent on use of server side programming languages and any could be used for the DCS, subject to individual server implementations.

There are multiple, possible providers of data channel applications including the local and the remote users. The data channel development process by local and remote users might be ad hoc and the communication service providers will not have its visibility.

All such web applications served to the local/remote user or people who are in its contact list should be considered trusted and as result already self-certified but the user.

Note 2: The data channel inclusion in the subscriber contract will probably include new terms and conditions (T&C) including explicit third parties' liability and consensus to accept the data channel applications.

The commercial development for other authorized parties associated with the local or remote network are expected to follow the iterative continuous development and integration process, which at least includes the following steps.

1. Requirement Analysis: Business requirements will be captured and documented to formulate the validation baseline. Those will include functional, non-functional and user interface aspects.
2. Design: Application content (HTML) and layout (CSS) are defined and prototyped using the toolchain.
3. Coding and Testing: Interactivity (JavaScript) and the server side logic (in its own language) is coded. Local deployment descriptors are developed for a server. IEEE-STD-610 defined verification will be executed locally on the selected software version. It will test whether the application meets all its specified requirements at the particular stage of its development.
4. Validation and Certification: Verified software is moved to a staging or reference systems to execute IEEE-STD-610 defined validation. It will ensure that the end product meets the true needs and expectations. The verification process should end with a certification which will determine the next steps, with two possibilities:
 - a) Validation failed and the next iteration needs to review the business requirements and run the corrective cycle.
 - b) Validation succeeded and the data channel application becomes the candidate for entry into the operational readiness preparations and placement into CSP business product catalogue.

From the commercial perspective, the acceptance, certification and validation are key processes where the developer need to execute including A/B testing. A/B testing is a randomized data channel user experience testing with two variants.

G.3 Data Channel Developer Toolchain

The data channel application development involves both the device and the server side business logic. The existing web toolchain is mature and complete to support both the client and the server side development process for HTML/JavaScript/CSS. It also supports WebRTC SDP component and its own media type's audio and video. Example tools that can be used by developers include:

Category	Available Tools
IDE (Integrated Development Environment)	Eclipse, Microsoft Visual Code, Netbeans.
Front-end Framework	React.js, Vue.js, Angular.js
Back-end Framework	Node.js
Version Control	Git
Module Bundler	Webpack, Rollup.js, Parcel, Grunt and Gulp

1 Table E.2-1 : Available tools of data channel developer

Note: Current IDE supports WebRTC development but not with IMS media types. The server emulator allowing developer level testing is also not available.

Data Channel APIs

The data channel application consists of the device side logic and the server side logic. Both should use standardized APIs that need to be agreed by the industry. W3C WebRTC1.0 data channel API specification is suggested as the preferred IMS data channel API. RTCPeerConnection, RTCDataChannel object, the call-backs need to be supported. Only data channel API related definitions are used and IMS data channel API is not allowed to use WebRTC media. ICE/STUN/TURN are also not required.

G.4 Data Channel UE Developer Runtime Environment

The data channel application will be tested and run against 5G UE execution environment described in Annex B. The key software components with which the developer needs to be familiar include:

- a) **Dialer:** Android native System Apps.
- b) **InCallUI:** The user interface component shown when the call is taking place.
- c) **JavaScript:** The baseline programming language and its extensions is used to create the web applications.
- d) ECMAscript / JavaScript defined by ECMA
- e) Web API defined by W3C

- f) **Data Channel JavaScript API:** JavaScript API used to establish and manage the application data channels. By default, IMS data channel API uses W3C WebRTC1.0 data channel API specification.
- g) **Webkit:** The browser engine which enable the execution of JavaScript code by its JavaScript engine, and render HTML pages by its WebView component (class android.webkit.WebView).

G.5 The Service Capability Exposure

3GPP TS 23.501[11] defines the Network Exposure Function (NEF) to securely expose 3GPP interfaces. The data channel service logic might be deployed and executed on the third party Application Functions (AF) as described in Annex A.

For the enterprise without the voice call and data channel capabilities, the bootstrap data channel, application data channel and RTP media are all terminated on the DCS. The DCS reports data channel related events and data channel application related information to the external AF. The service logic is executed on the external AF according to the events and information reported by the DCS through the NEF.

The NEF provides the secured northbound interface to the AFs and exposes the services and capabilities of the DCS through N33 interface specified in 3GPP TS 23.501 [11] and provides the support for:

1. Authentication and authorization of API requests from AF
2. Identification of the API consumer
3. Profile and SLA management per AF
4. Access control list and API firewall functionality
5. Message screening
6. The data channel related events
7. The data channel application related information

G.6 Data Channel Application Packaging, Release and Deployment

The data channel deployment model follows the standard web server process and can use it related toolchain.

Data Channel Application Packaging

A single [AppID] or [AppName] package will be created and it contains the data channel service logic and all required static resources. Its semantics and syntax are determined by CSP environment but it is expected to be linked to the inventory and possibly to the business product catalogue. It will be used to uniquely identify an application instance and to manage that particular instance. The AppID and its inventory name is needed to satisfy the detailed billing requirement which originate from the EU licencing directive which might require an itemized invoice with data channel application name and its consumption data. While the application needs to have either CRM or billing business product catalogue inventory name it does not imply that the application is visible to any parties, for instance when created by local user and available only for his or her use.

The files contained in a typical package are shown in Table E.5.1-1.

Component	Function	File Type	Mandatory	Description
Data Channel Server	Back End Business Logic	app.js (or app.class, etc.)	Yes	Server side business logic located under the DCS application root directory/or in different directories when an additional back end logic is involved and for instance PHP scripts are invoked. It might only contain configuration with no code when HTTP server is used to serve bootstrap channel
		app.json	Yes	Common network configuration for the application.
UE	Front End Business Logic	Index.html	Yes	The bootstrap channel page
		.html	No	Other application HTML pages (Note 2)
		.js	No	JavaScript UI business logic (Note 2)
		.css	No	Page style sheets (Note 2)
		app.json	No	UE configuration file defining application parameters, such the specific loss and latency. (Note 2)
		.jpg .jpeg .png .gif	No	Image resource files used by the UE side. (Note 2)
		.mp3 .mp4 .avi	No	Audio and video resource files used by the UE side (Note 2)

Table E.5.1-1 Data channel application deployment package content

Note 1: For simplicity it is assumed that the DCS executes the server side logic and no NEF is used.

Note 2: These files are not mandatory and could be located under any subdirectory depending on the implementation.

The delivery of the front end business logic between the DCS and UE should comply to HTTP/1.1 as specified by IETF RFC 2616 [17] (June 1999). It applies to any and all servers including proxies. The web principles should be used when files containing the front-end logic (i.e. user facing) are packaged on the back-end server and delivered by the bootstrap or the application channel.

The packaging of the back-end server logic should also follow the web principles. Those files execute the local back-end server logic but assist with the front-end functionality. When in doubt Apache Tomcat Server or Apache Web Server can be referred to understand the applicable principles.

Data Channel Application Deployment by Local or Remote Authorized Parties

The data channel application deployment is the process that follows the successful application development and certification (or self-certification) explained in the “Data Channel Development Process”. It will consist of the following steps when mass calling data channel services are deployed and controlled completely by the Communication Service Provider.

1. Establishing the operational readiness to offer the data channel services either by the service provider alone or both the service provider and the impacted enterprise.
2. Placing the data channel application in MBB business product catalogue.

Note: even if the application is provided by local or remote user it still needs to be included in the business product catalogue, because of billing or other regulatory requirements

3. The creation of the deployment package for the target system following the operating conventions.
4. Secured and traceable placement of the deployment package to the DCS production environment. The application may be downloaded using the DCS deployment client. This client can be used to validate, compile, compress to ZIP, WAR or other formats.
5. Manual deployment of the data service application by authorized operational personnel with the required administrative role assigned. The deployment is server specific but it might use <Context> element representing a *data channel application*, which is run within a particular virtual host. Each web might have corresponding directory containing the corresponding unpacked contents. In that case the manual deployment could involve creating the entry.

```
<Context path="/contentshare" docBase="/path/to/application/contentshare">  
</Context>
```

6. In general, in this case the developer will not be involved with the deployment or operations aspects. The process summary from the development to deployment is shown below.

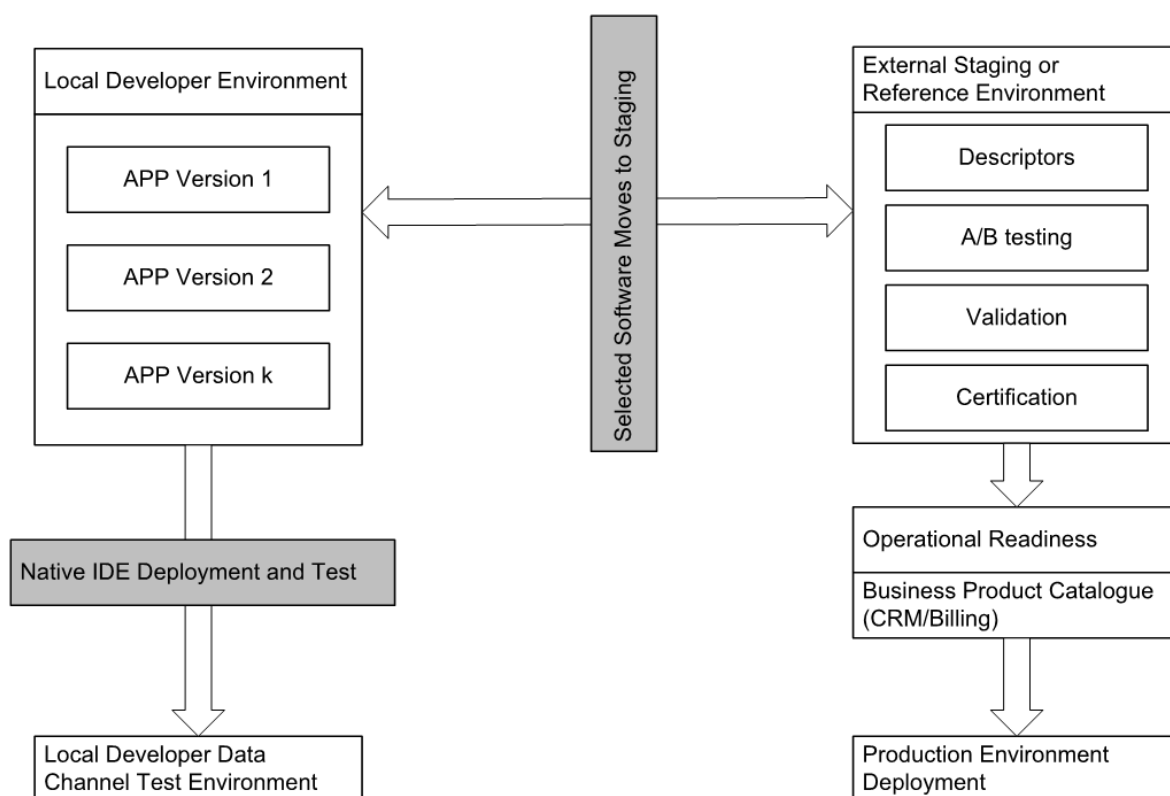

Figure E.5.2-1: Process summary from development to deployment

Data channel application deployment by local or remote users

The development and deployment process by the local or remote users is totally under their control. There is no operator involvement in this process and part of the assets are outside the operator control. The following applies:

1. Data channel server is used only as the repository to load the application logic.
2. Data channel server might be operator hosted and local or remote UE has direct access to their dedicated directories.
3. All the application logic is controlled by the local or remote user.
4. The back end servers are in the public or local user cloud and under the control of local/remote users.
5. The code can reference to any resource in the web using POST/GET.
6. The developer driven process is shown below and while it is very stable from the operator perspective it should be expected that it will be very turbulent on the developer side.

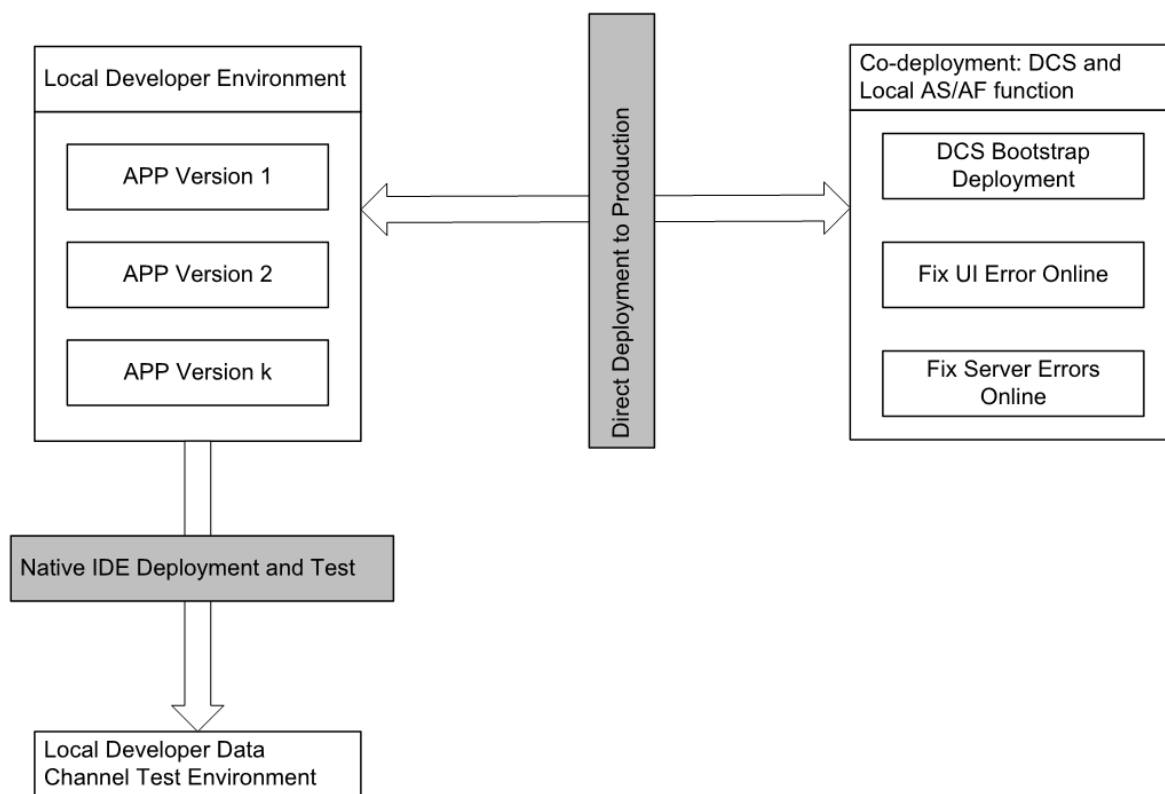

Figure E.5.3-1: Developer driven process.

Annex H Application Life-cycle Management

The data channel application will go through its own life-cycle and development cycle as new versions are created. Standard web application repositories, versioning tools and escrow might apply.

Where applicable the developer should receive the accounting information about the data channel usage or its reliability statistics.

The data channel application backup repository should be available and accessible for the whole application life-cycle and should be connected to the DCS in cases of system failure.

The DCS should support multiple versions of data channel application to enable A/B testing.

Annex I Data Channel Impact Study

I.1 Operator Impact Study

The Communications Service Provider (CSP) offering GSMA PRD IR.92 [8] or GSMA PRD NG.114 [9] defined IMS voice and planning to launch 3GPP TS 26.114 [1] specified IMS data channel services need to upgrade their infrastructure with the capabilities listed in the Table F.1-1.

Function	Required Change	Functional Specification
Data Channel Server	Introduce New Network Function	3GPP TS 26.114 [1] section 6.2.10 defined Data Channel Server network functionality.
Data Channel Application Repository	Introduce New Network Function	3GPP TS 26.114 [1] section 6.2.10 defined Data Channel Application Repository network functionality.
MMTel AS	Upgrade	3GPP TS 26.114 [1] section 6.2.10 defined IMS data channel negotiation during SIP SDP Offer/Answer. GSMA NG.129 [42] section 3.4.4 defined DC Control API.
P-CSCF (and PCF/PCRF for QoS hint)	Upgrade	3GPP TS 29.214 [40] Annex A.2 or 3GPP TS 29.514 [41] Annex B.16 specified support for QoS hint for IMS data channel media and 3GPP TS 24.229 [2] for support for WebRTC DC signalling and media
IMS AGW	Upgrade	
IBCF	Upgrade	3GPP TS 29.165 [10] section 33 specified IMS data channel support for II-NNI.
TrGW	Upgrade	
MRFC	Upgrade or new MRFC for DC	GSMA NG.129 [42] section 3.4 defined IMS data channel media function.
MRFP	Upgrade or new MRFP for DC	
UE	Upgrade	3GPP TS 26.114 [1] section 6.2.10 defined support for IMS data channel media feature.
Business Support System	Upgrade	CSP defined provisioning of IMS data channel services. 3GPP or GSMA yet to be defined billing for IMS data channel service.
Operation Support Systems	Upgrade	CSP defined IMS data channel fault, configuration, accounting, performance, and security.

Table Error! No text of specified style in document.-1 : CSP IMS data channel impact planning

I.2 Enterprise Impact Study

3GPP Release 16 TS 26.114 [1] enables enterprises with the IMS data channel capability. P2A/A2P scenarios might use the IMS data channel technology to optimize a range of business processes like product discovery, customer acquisition, life-cycle management, customer support and marketing. The two enterprise architectures described in this document include:

2. Legacy enterprise relies on 3GPP Release 15 or earlier IMS communication capabilities and as result deploys P2LA/LA2P interworking configurations. There are no changes to the enterprise communication infrastructure and only the CSP with whom the enterprise has the contract deploys the data channel capabilities.
3. Data channel capable enterprise relies on 3GPP Release 16 or later IMS communication capabilities. Both the CSP and the enterprise deploy the data channel capabilities and support interconnecting for P2DA/DA2P configurations.

Table F.2-1 lists the required enterprise functional upgrades to support the IMS data channel.

Function	Required Change	Functional Specification
Data Channel Portal	Upgrade/New	CSP defined method for the enterprise data channel service deployment to the CSP data channel repository. This is needed by enterprise to activate its A2P/P2A applications once the CSP provisioned the IMS data channel service for the enterprise specific MSISDN. Note: this is the single requirement to enable the IMS data channel service for legacy enterprises.
Enterprise SBC	Upgrade	3GPP TS 26.114 [1] section 6.2.10 defined IMS data channel negotiation during SIP Offer/Answer. 3GPP TS 26.114 [1] section 6.2.10 defined initiation and termination of application data channel(s). 3GPP TS 24.229 [2] for DC signalling Enterprise specific IMS data channel accounting
Enterprise Firewall	Upgrade	The application traffic might need to be firewall screened between the enterprise SBC and the enterprise application server.
Enterprise Application Server	Update	Enterprise defined and hosted execution environment for the server-side logic of enterprise IMS data channel applications.
Enterprise O&M	Upgrade	Enterprise defined IMS data channel operations and maintenance.

Table F.2-1: Enterprise IMS data channel impact planning

Annex J Standardization Status

The data channel has been enabled by the cooperation of multiple stakeholders. The following organisations are the custodians of data channel standards:

1. IETF: standardized baseline protocols and media processing for both IMS and WebRTC.
2. 3GPP: standardized 5G mobile protocols, including IMS.
3. W3C: standardized the WebRTC data channel component API, which is planned to be reused by IMS data channel applications.
4. GSMA: developed 5G profiles and commercial principles for IMS.

This section summarizes the gaps and future developments that might be impacted by the IMS data channel.

J.1 3GPP

The current 3GPP standards are complete, and they contain sufficient provisions to deploy the data channel services in 5G networks. There are no identified gaps.

The relevant 3GPP Release 15/16 standardisation efforts which resulted in the current 5G IMS data channel specifications are summarized below.

3GPP support for IMS services in 5G system is defined in 3GPP TS 23.228 [13], 3GPP TS 23.501 [11], 3GPP TS 23.502 [16], and 3GPP TS 23.503 [3].

3GPP Release 15 initiated several study items / work items with the objective to enrich IMS services capabilities, specifically the user plane. Those studies resulted in the current data channel capabilities and are listed in Table G.1-1.

3GPP Unique ID	3GPP SID/WID Title	Description
760041	Study on Media Handling Aspects of Conversational Services in 5G Systems (FS_5G_MEDIA_MTSI)	Release 15 study item that investigated media handling aspects of conversational services in 5G, and documented several recommendations on Multimedia Telephony Service over IMS (MTSI) in TS 26.114 around media rate adaptation, New Radio (NR) access and profiles for 5G deployments
790021	Media Handling Aspects of Conversational Services in 5G Systems (5G_MTSI_Codecs)	Release 15 work item that addressed normative aspects around speech and video codecs, based on conclusions of TR 26.919
800001	Enhancements to Framework for Live Uplink Streaming (E_FLUS)	Release 16 work item where the MTSI-based instantiation uses a different set of QoS than previously defined MTSI media components, which this work item may also do and could therefore benefit from finding a common approach to choose specific QoS.
810002	Media Handling Extensions for 5G Conversational Services (5G_MEDIA_MTSI_ext)	Release 16 work item that addressed the media extensions for 5G conversational services, e.g. to support IMS data channel.

Table G.1-1: 3GPP SID /WID related to IMS Data Channel

Release 16 work item 5G_MEDIA_MTSI_ext resulted in the current IMS data channel specifications 3GPP TS 26.114 [1], 3GPP TS 24.229 [2], including the definition of new media component "data". Related procedures for supporting IMS data channel are also specified in 3GPP TS 26.114 [1], 3GPP TS 24.229 [2], and 3GPP TS 29.165 [10], describing UE behaviour and SDP negotiation procedure, etc.

J.2 GSMA

The current GSMA Permanent Reference Documents (PRDs) are not complete with respect to profiling IMS data channel. They only contain the description how the IMS data channel is associated with an MMTel voice or video call as profiled in GSMA PRDs IR.92 [8] and NG.114 [9], but the following gaps still remain.

Working group	PRD	Description
NG 5GJA	NG.113 5GS Roaming Guidelines	Data channel media type needs to be added to the relevant sections. For example: 1) In Annex A Guidelines for Proposed Basic QoS Parameters for N9HR Roaming Scenario, the proposed 5QI values of IMS data channel service should be added into the table. 2) Section 6.2.2.2 IMS Voice Roaming Architecture N9HR should add data channel requirements on VPMN and HPMN.

WAS	BA.27 Charging Principles	Charging principles for NR based packet switched bearer services and IMS data channel services need to be added.
NG GSG	RCC.20 Enriched Calling Technical Specification	The alternative way of implementing the pre-call and in-call enriched calling using data channel might be described.
FASG	FS.38 [46] SIP Network Security	The new data channel media tag should be added to the document.
NG	IR.25 VoLTE Roaming Testing	IREG tests should be defined for data channel originating and terminating calls.

Table G.2-1: The gaps identified in the current GSMA profiles

J.3 IETF

The standards are complete for the WebRTC data channel and there are not known gaps.

J.4 W3C

The current WebRTC data channel API has been standardized and it is completed. There are not known gaps at the definition level when WebRTC API is used over Internet APN. However, a second APN-aware WebRTC data channel API implementation in the UE may be required so the UE can invoke the IMS data channel capability over the IMS APN.

Annex K Document Management

K.1 Document History

Version	Approval Date	Brief Description of Change	Approval Authority	Editor / Company
0.1	05/03/2021	New White Paper document skeleton content as per 5GJA#15 Doc 112 agreement created	5GJA#15	Walter Zielinski (Huawei)
0.1 0.9 06	09/06/2021	<p>“What is data channel “sections 1.3,3, 3.1, 3.2,3.3</p> <p>“Data Channel Use Cases “sections 10,10.1,10.1.1-10.1.3,10.2, 10.2.1-10.2.4</p> <p>“3GPP Status “section 11.1</p> <p>“Simultaneous Translation” section 10.1.4</p> <p>“Data Channel Application Market” sections 8.1-8.7</p> <p>“Document Title and Document Header” corrections</p> <p>“Enriched Calling” section 6.3</p> <p>Implemented “P2P P2A Architecture” section 3.4.2</p> <p>“Data Channel Ecosystem” sections 7.1,7.1.1-7.1.4, 7.3</p> <p>“Interactive ringback tone” section 10.1.6</p> <p>“Interactive ringing” section 10.2.2</p> <p>“Pre-call multimedia information presentation” section 10.1.5</p> <p>“QoS framework and data channel” section 3.4.7</p> <p>“GSMA IETF W3C” section 11.3.1</p> <p>“Interconnect” section 3.2.6</p> <p>“A2P Architecture” section 3.4.2.4</p> <p>“Beyond MMTEL” section 14</p>	Data Channel Task Force	Walter Zielinski (Huawei)
0.2	15/07/2021	<p>“DC Control API” section 3.4.7</p> <p>“Data channel Protocol Stack” section 3.4.1</p> <p>“Roaming” section 3.4.3</p> <p>“Device Support of Data Channel” section 4.X restructuring</p>	Data Channel Task Force	Walter Zielinski (Huawei)

Version	Approval Date	Brief Description of Change	Approval Authority	Editor / Company
0.3	20/09/2021	CMCC “Operator Story” section 9.1 BT “Operator Story” section 9.2 “Conclusions and Recommendations” section 15 “Industry vision” section 2 “UE architecture” section 4.1, 4.2 “Enterprise trust chain” section 10.6 “Security and Privacy” section 12.4 “Regulatory” section 12.7 “Terminal requirements” including chipset section 12.3 “Network Requirements” section 12.2 “Impact Study” section 13.1	Data Channel Task Force	Walter Zielinski (Huawei)
0.4	27/09/2021	“DCS Architecture” principles Annex A “Document history” Editorial changes, picture updates Alignment between DCS architecture and P2P/A2P/P2A		
1.0	03/11/2021	CR1001 First Document Version Additional contributors: BT, CMCC, Ericsson, Huawei, ZTE	NG	Walter Zielinski / Huawei
1.1	14/12/2023	CR1002 – Conclusions and Recommendations	NG	Walter Zielinski / Huawei
1.2	15/04/2025	CR1003 – Resume from the point you left off	NG	Walter Zielinski / Huawei

Other Information

Type	Description
Document Owner	Networks / Packet
Editor / Company	Walter Zielinski / Huawei

It is our intention to provide a quality product for your use. If you find any errors or omissions, please contact us with your comments. You may notify us at JSendin@gsma.com

Your comments or suggestions & questions are always welcome.