



# Network and services use cases for IR.21/IR.85

## Version 1.0

### 24 April 2026

---

#### **Security Classification: Non-Confidential**

Access to and distribution of this document is restricted to the persons permitted by the security classification. This document is subject to copyright protection. This document is to be used only for the purposes for which it has been supplied and information contained in it must not be disclosed or in any other way made available, in whole or in part, to persons other than those permitted under the security classification without the prior written approval of the Association.

#### **Copyright Notice**

Copyright © 2026 GSM Association

#### **Disclaimer**

The GSMA makes no representation, warranty or undertaking (express or implied) with respect to and does not accept any responsibility for, and hereby disclaims liability for the accuracy or completeness or timeliness of the information contained in this document. The information contained in this document may be subject to change without prior notice.

#### **Compliance Notice**

The information contain herein is in full compliance with the GSMA Antitrust Compliance Policy.

This Permanent Reference Document is classified by GSMA as an Industry Specification, as such it has been developed and is maintained by GSMA in accordance with the provisions set out GSMA AA.35 - Procedures for Industry Specifications.

## Table of Contents

<b>1</b>	<b>Introduction</b>	<b>3</b>
1.1	Scope of document	3
1.2	Definitions	3
1.3	Abreviation	3
1.4	References	5
<b>2</b>	<b>Uses cases for the release upgrade</b>	<b>6</b>
2.1	Use cases for Release 17	6
2.2	Use cases for Release 18	8
<b>3</b>	<b>Use cases per network type</b>	<b>10</b>
3.1	Overall context	10
3.2	Basic network type - Terrestrial – mono MCC-MNC (IMSI)	12
3.3	Basic network type - Non-Terrestrial (Aeronautical, maritime)	13
3.4	Basic network type – Full MVNO	13
3.5	Basic network type - M2M dedicated providers (M2MDO)	14
3.6	Additional Network type + Multi user MCC-MNC (IMSI)	14
3.7	Additional Network type + Multi network MCC-MNC	15
3.8	Additional Network type + Light MVNO	15
3.9	Additional Network type + M2M integrated Solutions (M2MIS)	15
3.10	Additional Network type + Network Sharing (MOCN)	17
3.11	Additional Network type + Network Extension (same MCC-MNC) – Hosted networks	17
3.12	Additional Network type + Network coverage Extension (new MCC-MNC)	18
3.13	Network type mapping	18
<b>4</b>	<b>Use cases per roaming services</b>	<b>19</b>
4.1	2G/3G sunset	19
4.2	4G opening	22
4.3	VoIMS opening	26
4.4	MloT opening	28
4.5	5G SA opening	33
4.6	Emergency service opening	36
4.7	Mission Critical service opening	39
4.8	Service type mapping	41
<b>5</b>	<b>Additional guidelines per section</b>	<b>42</b>
5.1	Messaging interworking opening	42
5.2	Contacts	42
<b>6</b>	<b>Additional guidelines for roaming hub</b>	<b>42</b>
<b>Annex A</b>	<b>Document Management</b>	<b>43</b>
	Document History	43
	Other Information	43

# 1 Introduction

## 1.1 Scope of document

This document was created to help the GSMA Industry Specification IR.21 administrator to fill in correctly the GSMA Industry Specification IR.21 [2] based on different use cases:

- IR.21 release
- network type
- roaming service
- other

## 1.2 Definitions

For the purposes of the present document, the following terms and definitions apply. The term “Section” into this document refers to the GSMA Industry Specification IR.21 [2] section identity.

Various definitions could be found in GSMA Industry Specification WA.03 [1].

## 1.3 Abreviation

Term	Meaning
AAA	Authentication, Authorization, Accounting
AML	Advanced Mobile Location
API	API Application Programming Interface
APN	Access Point Name
ASN	Autonomous System Number
CAMEL	Customized Applications for Mobile networks using Enhanced Logic
CAP	CAMEL Application Part
CC	Country Code
CMM	Connected Mode Mobility
CE	Coverage Enhancement
DNS	Domain Name Service
eCall	Emergenct call for Car ecosystem
eDRX	Extended Discontinuous Reception
ETS	European Telecommunications Standard
ETSI	European Telecommunications Standards Institute
FQDN	Fully Qualified Domain Name
GPRS	General Packet Radio Service
GSMA	GSM Association
GRX	GPRS Roaming Exchange
GSN	GPRS Support Node

<b>Term</b>	<b>Meaning</b>
GUI	Graphical User Interface
GW	Gateway
GTT-IP	Global Text Telephony over IP
IMSI	International Mobile Station Identity
IoT	Internet of Things
IP	Internet Protocol
IPX	IP eXchange
LPWA	Low Power Wide Area
LTE	Long Term Evolution
LTE-M	LTE Cat-M1
LWPA	Low-Power Wide-Area
M2M	Machine-2-Machine
M2MDO	Machine-2-Machine Dedicated Operator
M2MIS	Machine-2-Machine Integrated Solution
MAP	Mobile Application Part
MCC	Mobile Country Code
MCX	Mission Critical
MGT	Mobile Global Title
MNC	Mobile Network Code
MOCN	Multi-Operator Core Network
MSC	Mobile Services Switching Centre
MSISDN	Mobile Subscriber ISDN Number
MSRN	Mobile Subscriber Roaming Number
MVNO	Mobile Virtual Network Operator
MNO	Mobile Network Operator
NAS	Non-Access Stratum
NB-IoT	Narrowband IoT
NC	Network Code
NDC	National Destination Code
PC	Point Code
PMN	Public Mobile Network
PRD	Permanent Reference Document
PSM	Power Saving Mode
RAEX	Roaming Agreement Exchange
RH	Roaming Hub

Term	Meaning
RVAS	Roaming Value Added Service
RTT	Real Time Text
SCCP	Signalling Connection Control Part
SH	Service Hub
SMSC	Short Message Service Centre
SS7	Signalling System no. 7

**Table Caption 1 : Glossary**

## 1.4 References

Ref	Doc Number	Title
[1]	GSMA PRD WA.03	WAS Definitions & Abbreviations
[2]	GSMA PRD IR.21	GSM Association Roaming Database, Structure and Updating
[3]	GSMA PRD IR.88	EPS Roaming Guidelines
[4]	GSMA PRD NG.113	5GS Roaming Guidelines
[5]	GSMA PRD NG.121	2G-3G Sunset Guidelines
[6]	GSMA PRD NG.111	SMS Evolution
[7]	GSMA PRD BA.46	Non-Terrestrial Roaming Principles
[8]	GSMA PRD BA.21	Network Extension Principle
[9]	GSMA PRD BA.48	M2M Roaming Principles
[10]	GSMA PRD IR.85	IREG Hubbing Provider Data, Structure and Updating Procedures
[11]	GSMA PRD NG.119	Emergency Communication
[12]	GSMA PRD NG.150	Mission Critical Communications Roaming Guidelines
[13]	GSMA PRD FS.21	Interconnect Signalling Security Recommendations
[14]	GSMA PRD NG.117	MIoT Roaming Guidelines
[15]	GSMA PRD IR.65	IMS Roaming, Interconnection and Interworking Guidelines
[16]	GSMA PRD IR.64	IMS Service Centralization and Continuity Guidelines
[17]	3GPP TS 33.107	3G security; Lawful interception architecture and functions

## 2 Uses cases for the release upgrade

### 2.1 Use cases for Release 17

This part will describe the use cases and parameters associated to release 17 introductions.

#### 2.1.1 R17 General

- Restrict GT leasing network owner option to global title number ranges.
- Updated pre-emption vulnerability and capability type definitions
- New data dictionary checks
  - Checks based on supported services
  - VPMN- and HPMN-only checks
  - GRX/IPX routing checks
- Updated PDF: Better alignment with the RAEX creator user interface
- New visibility options
  - Data from sections 1, 2 and 21 will now always be available in the IR.21 catalog and reports
  - All other sections can now be hidden
  - The option to completely hide a document has been removed
- The IR.21 catalog will now show the actual TADIG codes that are covered in a document.
- Updated existing IR.21 reports.
- Added three new IR.21 reports.
  - TADIG summary, Radio frequencies and Services

#### 2.1.2 R17 Schema and Rules updates

##### 1. Organisation

- Updated network type options
  - Renamed M2M Dedicated into M2M Dedicated Operator (M2MDO)
  - Added new option M2M Integrated Solution (M2MIS)

##### 2. Network

- Aligned capitalization of some frequencies.
- Added new E-UTRA and 5G NR frequencies.
- Enhanced existing service status and planned closure information.
  - Radio network services
  - Core network services.

##### 4. Routing

- MGT and MSISDNs are now optional for VPMN-only operators.
- GT leasing details have been added to leased GT number ranges.
- Changed order of operator ID and translation type columns (IR.85 only)

### 13. Network Elements

- New node types have been added: AAA, ePDG and TWAG.

### 15. CAMEL

- Removed CAPv4 options.
- Removed gprsSSF SGSN subsection.

### 16. Packet Data Services

- Changed pre-emption vulnerability and capability in QoS profiles from list to single value and made the selected option more explicit.

### 17. GRX/IPX Routing for Data Roaming

- Authoritative DNS servers are now optional.
- IPX VLAN attribute has been added for connections to inter-PMN IP backbone (IPv4 + IPv6)

### 20. LTE Roaming

- Removed SMS Interworking elements, as there is now a dedicated SMS Roaming section
- Changed pre-emption vulnerability and capability in QoS profiles from list to single value and made the selected option more explicit.
- Updated EPC realm pattern

### 21. Contacts

- Added new Certificates and Key Management contact.
- Added new Escalation Contact for 24/7 Troubleshooting (out of office hours)
- Removed fax attribute.

### 23. M2M Roaming

- Removed M2M APNs available for testing and troubleshooting as these are already part of the Packet Data Services section.

### 26. VoIMS Roaming

- VoLTE Roaming section has been renamed.
- Added N9HR roaming architectures.
- State if AMF announces the emergency number list toward inbound roamer's UE.
- Updated VPLMN technology strategies for emergency calls
- Removed validity dates from emergency number URNs.

### 27. LPWA Roaming

- State support for IPX GTP firewalls.
- Simplified elements for outbound services: Power saving + eDRX
- Removed some parameters for outbound services: Release assistance indication rel. 13 + 14, RRC inactivity timer duration, UE power class support, CMM, CE

## 28. 5G SA Roaming

- New section
- 5G SA signalling / SEPP information
- Supported roaming architectures.
- 5G QoS profiles

## 29. SMS Roaming

- New section
- SMS delivery mechanisms as HPLMN / VPLMN

## 2.2 Use cases for Release 18

This part will describe the use cases and parameters associated to release 18 introductions.

### 2.2.1 R18 Schema and Rules updates

The following schema modifications, or rules are applied on the following topics:

#### 1. Organization:

- Add a new network type (Satellite/Space)

#### 2. Network:

- Add MCX information in Service Status and Planned Closure and availability (Core network)
- Add a table for Home Services
- Coverage parameter could be Global (for satellite)

#### 4. Routing Information:

- Section 4 is split into IMSI and MSISDN sections.
- Add MSISDN length.
- Improvement of the description of MSRN, MSISDN and MGT (Conditional parameters)
- Remove “15 digits MSISDN support” parameter.

#### 12. SMS hub

- Add section 12 SMS Hubbing information.

#### 16. Packet Data service

- Separate section 16 into 2 sections:
  - Existing section 16.1: Packet Data service: APN (valid for all techno 2/3/4/5G)
  - New section 16.2 GPRS Data network: some GPRS information (QoS part)

### 17. GRX/IPX Routing for data roaming

- a more manageable management of MNO and IPX ASN (drop down list)

### 20. IP management

- IP address ranges: the value(s) should have a subnet mask, e.g. host addresses shall be specified as /32.

### 20. Contact

- Clarify the instructions and add a new field under "Roaming Troubleshooting Ticketing System" to specify the Troubleshooting Receipt Preference.
- Make "Team Name" and "Person Name" selectable for all contact types, allowing operators to enter either a team name or a person's name as appropriate.
- Make both Telephone number and Email required for mandatory Contact information to enhance the reachability of e, g, test contacts.

### 29. SMS:

- SMS parameters become Mandatory.

### 30. Emergency:

- New section related to Emergency services
- Add GTT, eCall and AML services.
- Additional parameter on Emergency (unauthenticated, without UICC)

### 31. Inbound roaming protection

- Add a new section 31 on Roaming protection.
- Add per techno (SS7, Diameter, GTP, HTTPs) the protection coverage (All, Partial, Not Disclosed) on Inbound Roaming Protection, as defined in FS.21 [13] section 16.

### Rules

- Add an excel file describing the different rules applied on the IR.21 parameters.

## 2.2.2 R18 Tool

Some RAEX Tool improvements are listed hereafter:

- The behavior of the default value of some sections
- Reintroduction of the concept of IR.21 validity that was already defined in the approved CR1017.
- Download improvement.
- Tag "ID: number" per section in the PDF IR21
- Add IR.21 implementation status.
- Drop down list for IPX providers / SMS hub.

## 2.2.3 R18 Process

Some process improvements are listed hereafter:

- Confidentiality:
  - Recommendation to move to GSMA confidential (the parameters will be then in the Reports)
- Improvement release management
  - Some operators continue to use outdated IR.21 versions, while others move to a new IR.21 release without enough time to review the changes, which may result in incorrect entries. This change will encourage the adoption of the latest version and clarify the timing and method of notifications, ensuring operators are promptly informed and have more time to prepare for the update.

### 2.2.4 R18 Reports

Some report improvements are listed hereafter:

- Update current reports:
  - Reports for emergency
  - Introduce principal TADIG code (Sender TADIG code in header) in all existing and new reports on top of TADIG code associated with a specific section.
  - Update IP report with VLAN parameters (See IR.21 [2] H.8)
  - new Network Node report with IPV6 parameters (See IR.21 [2] H.6)
- New reports:
  - add 14 new IR.21 reports: IR.21 version, MGT, Short number translation, 2G/3G QoS Profiles, Authoritative DNS Servers, Local Caching DNS Servers, GRX/IPX Providers, LTE QoS Profiles, VoIMS roaming, 5G QoS Profiles, SEPP information, SMS Capability, IP v6 (IR.21 [2] H.9)

## 3 Use cases per network type

### 3.1 Overall context

The GSMA PRD IR.21 [1] is designed in such a way to cover different use cases, which are described in the figure hereafter.

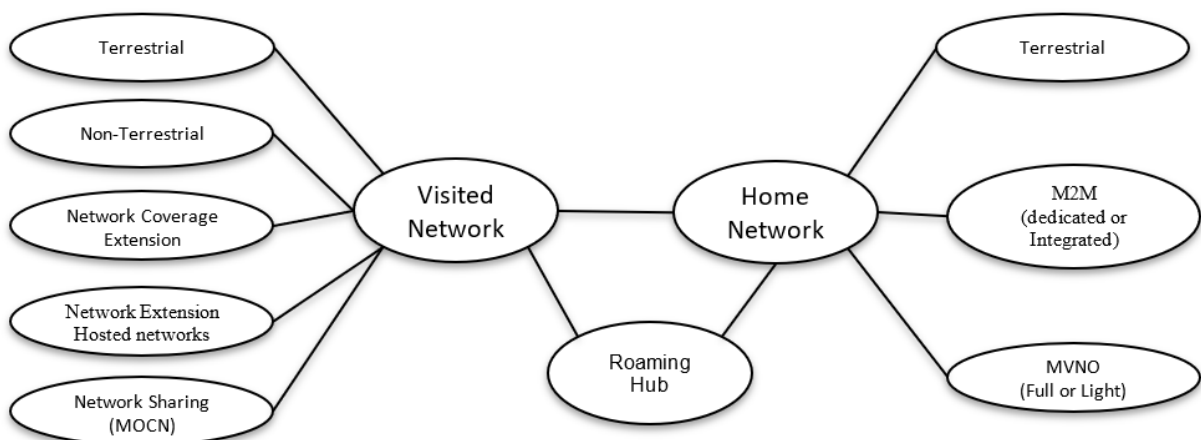

Figure 1: Use Cases

Note: The Roaming Hub case is described for GSMA PRD IR.85.

The first list describes the basic network type, which could be defined as the first network type in GSMA PRD IR.21 [1]

- Terrestrial – mono MCC-MNC (IMSI)
- Non-Terrestrial (Aeronautical, maritime)
- Full MVNO
- M2M Dedicated Operator (M2MDO)

The second list describes the additional network type, which could be defined on top of the basic network type in GSMA PRD IR.21 [1]

- + Multi user MCC-MNC (IMSI)
- + Multi network MCC-MNC
- + Light MVNO
- + M2M Integrated Solution (M2MIS)
- + Network Sharing (MOCN)
- + Network Extension (same MCC-MNC) – Hosted networks
- + Network Extension (new MCC-MNC)

Each operator is identified by a unique code called “Sender TADIG Code”.

An operator could play one or several roles as described before. Some roles will be identified by a “TADIG code”.

For example, Orange France Sender TADIG code is FRAF1.

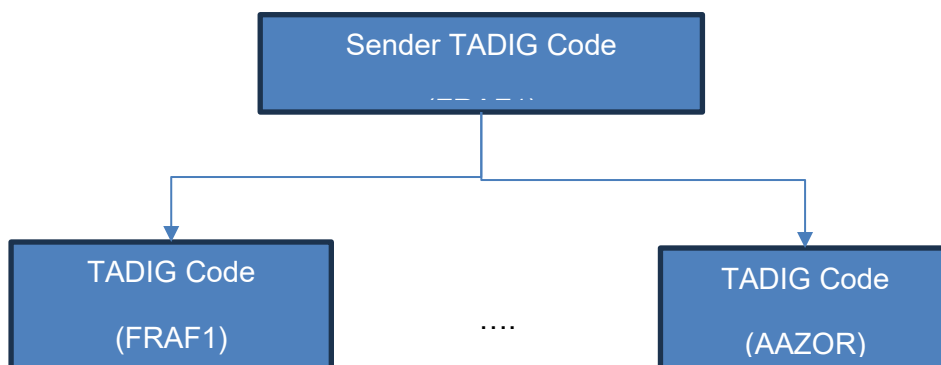

**Figure 2 MNO with 2 TADIG Codes**

Orange France has 2 TADIG codes:

- FRAF1 for terrestrial network (using MCC/MNC=20801)
- AAZOR for M2M (using MCC/MNC=90131)

Section 1 (organization information) will contain the overall picture of the operator, defining which network type is really implemented by the operators.

### TADIG summary

TADIG	MCC/MNC	VPMN/HPMN	Network Type
-------	---------	-----------	--------------

The table hereafter summarizes the different network types described above:

- V (VPLMN) for inbound roaming
- H (HPLMN) for outbound roaming

TADIG	MCC-MNC	V/H	Network type
Basic	Basic	V/H	Terrestrial
Basic	Basic	V	Non-Terrestrial
Basic	Basic	H	Full MVNO
Basic	Basic	H	M2M Dedicated Operator (M2MDO)
Additional	Additional	H	+ Multi user MCC-MNC IMSI
Additional	Additional	V	+ Multi network MCC-MNC
Same	Same	H	+ Light MVNO
Same	Same	H	+ M2M Integrated Solution (M2MIS)
Same	Additional	V	+ Network Sharing
Additional	Same	V	+ Network Extension (same MCC-MNC)
Same	Additional	V	+ Network Coverage Extension (different MCC-MNC)

**Table 1 : Different network types**

### 3.2 Basic network type - Terrestrial – mono MCC-MNC (IMSI)

The Terrestrial Roaming is roaming related to a Territory as identified by the ITU, for example Canada, Italy or United Kingdom.

Terrestrial operators are composed of:

- Visited network: identified by MCC-MNC broadcast on radio network and associated TADIG Code
- Home network: identified by a unique MCC-MNC assigned to end user (IMSI) and associated TADIG Code

Key parameters specific to Terrestrial networks are:

- Section 1 (organization information) example - NTT (Japan)

Sender TADIG	TADIG	MCC-MNC	V/H	Network type
JPND0	JPND0	440-10	V/H	Terrestrial

**Table 2 : Organization information example with single IMSI**

- Section 4 (Routing information): E.212 number (MCC-MNC) is used to identify
  - MCC-MNC broadcasted on radio network for the Visited network
  - MCC-MNC assigned to end user (IMSI) for the Home network

### 3.3 Basic network type - Non-Terrestrial (Aeronautical, maritime)

Non-terrestrial operators are wholly independent from any Terrestrial network and operate in International Zones and National Zones such as International Waters or Airspace where they are authorised to do so.

Non-Terrestrial operators are composed of Visited network, identified by MCC-MNC broadcast on radio network and associated TADIG Code (Aircraft operators: AAA and Maritime operators: AAM). Non-terrestrial networks could optionally have a Home network.

Non-terrestrial Roaming principles are defined in GSMA PRD BA.46 [7].

Key parameters specific to Non-Terrestrial networks are:

- Section 1 (organization information) example - Tampnet AS

Sender TADIG	TADIG	MCC-MNC	V/H	Network type
AAMT1	AAMT1	901-71	V	Non Terrestrial (maritime)

**Table 3 : Organization information example for Non -Terrestrial organization**

- Section 4 (Routing information): E.212 number (MCC-MNC) is used to identify
  - MCC-MNC broadcasted on radio network for the Visited network
  - MCC-MNC assigned to end user (IMSI) for the Home network

### 3.4 Basic network type – Full MVNO

A mobile virtual network operator (MVNO) is a mobile operator that does not own the mobile network infrastructure over which it provides services to its customers.

MVNOs are composed of Home network, identified by MCC-MNC assigned to end user (IMSI) and associated TADIG Code.

Full MVNO owns their own MCC-MNC (and associated TADIG code), and uses most of the time an MNO in order to deploy international roaming.

Key parameters specific to Full MVNO networks are:

- Section 1 (organization information) example - Com4 Sweden

Sender TADIG	TADIG	MCC-MNC	V/H	Network type
SWEC4	SWEC4	240-09	H	Full MVNO

**Table 4 : Organization information example for full MVNO**

- Section 4 (Routing information): E.212 number (MCC-MNC) is used to identify
  - MCC-MNC assigned to end user (IMSI) for the Home network

### 3.5 Basic network type - M2M dedicated providers (M2MDO)

A Machine-2-Machine (M2M) provider is a mobile actor that deploys Machine communication technology. An M2MDO is an M2M Dedicated MNO which supplies only M2M specific traffic over an independent MCC/MNC and TADIG code providing full transparency towards roaming partners of its M2M Customers. M2M Roaming principles are defined in GSMA PRD BA.48 [9].

M2MDO providers are composed of Home network, identified by MCC-MNC (distinct 901 code issued by ITU) assigned to end user (IMSI) and associated TADIG Code.

Key parameters specific to M2MDO networks are:

- Section 1 (organization information) example - Sierra Wireless France

Sender TADIG	TADIG	MCC-MNC	V/H	Network type
AAZ24	AAZ24	208-24	H	M2M Dedicated Operator

**Table 5 : Organization information example with dedicated providers**

- Section 4 (Routing information): E.212 number (MCC-MNC) is used to identify
  - MCC-MNC assigned to end user (IMSI) for the Home network
- Section 23 (M2M Roaming Information) could contain subrange of IMSI defined for M2M

### 3.6 Additional Network type + Multi user MCC-MNC (IMSI)

Some operators have multiple MCC-MNC ranges (and associated TADIG code) to define their subscribers (IMSI). The additional MCC-MNC could be defined in GSMA PRD IR.21 [1], in an additional section 4 defining the additional MCC-MNC associated to subscribers.

Key parameters specific to Multi user MCC-MNC are:

- Section 1 (organization information) example – ATT (USA)

Sender TADIG	TADIG	MCC-MNC	V/H	Network type
USACG	USACG	310-410	V/H	Terrestrial
USACG	USAMF	310-280	H	Terrestrial
USACG	USAAT	310-280	H	Terrestrial
USACG	USABS	310-150	H	Terrestrial
USACG	USAPB	310-170	H	Terrestrial
USACG	USACC	310-030	H	Terrestrial
USACG	USAFN	310-100	H	Terrestrial

**Table 6 : Network type with Multi user MCC-MNC**

- Section 4 (Routing information): E.212 number (MCC-MNC) is used to identify
  - MCC-MNC assigned to end user (IMSI) for the Home network

### 3.7 Additional Network type + Multi network MCC-MNC

Some operators have multiple MCC-MNC ranges (and associated TADIG code) to define their networks. The additional MCC-MNC could be defined in GSMA PRD IR.21 [1], in an additional section 4 defining the additional MCC-MNC associated to networks.

Key parameters specific to Multi network MCC-MNC are:

- Section 1 (organization information) example – Bartel (India)

Sender TADIG	TADIG	MCC-MNC	V/H	Network type
INDAT	INDAT	404-10	V/H	Terrestrial
INDAT	INDA8	404-93	V/H	Terrestrial
INDAT	INDA9	404-02	V/H	Terrestrial
INDAT	INDSC	404-40	V/H	Terrestrial
INDAT	IND07	404-95	V/H	Terrestrial
...				

**Table 7 : Network type + Multi network MCC-MNC**

- Section 4 (Routing information): E.212 number (MCC-MNC) is used to identify
  - MCC-MNC assigned to network for the Visited network

### 3.8 Additional Network type + Light MVNO

An MVNO could be hosted by an MNO inside its own MCC-MNC ranges. Some sections (GT, IP, ASN ...) enable the addition of attributes to mention Light MVNO usage. Key parameters specific to Light MVNO networks are:

- Section 1 (organization information) example – Telstra Australia

Sender TADIG	TADIG	MCC-MNC	V/H	Network type
AUSTA	AUSTA	505-01	V/H	Terrestrial
AUSTA	AUSTA	505-01	H	Light MVNO (Lycamobile)

**Table 8 : Network type + Light MVNO**

- “Network Owner” could be filled with “MVNO” value for
  - Section 4 (Routing information): MSISDN number, GT number
  - Section 17 (IP-Roaming and IP-Interworking Information): IP, IPv6, Any additional MNC/MCC-RAI, MNO’s ASN, Any additional MNC/MCC-ULI, authoritative DNS server, local caching DNS server, PMN ENUM Servers, GRX/IPX provider(s)

### 3.9 Additional Network type + M2M integrated Solutions (M2MIS)

A Machine-2-Machine (M2M) provider is a mobile actor that deploys Machine communication technology. M2MIS are M2M solutions hosted by MNOs where the M2M Traffic is integrated (or included) within their existing MNO traffic. The M2M usage is not defined at the network level

and may or may not be defined at the billing level with independent MCC/MNC and TADIG codes.

M2M Roaming principles are defined in GSMA PRD BA.48 [9].

Transparency is provided for the M2MIS by using APNs or IMSI sub-ranges, which could be defined in M2M section 23.

Key parameters specific to M2MIS are:

- Section 1 (organization information) example – POST Luxembourg

Sender TADIG	TADIG	MCC-MNC	V/H	Network type
LUXPT	LUXPT	270-01	V/H	Terrestrial
LUXPT	LUXPT	270-014 270-016001	H	M2M Integrated Solution

**Table 9 : Network type for company with M2M integrated Solutions**

- Section 23 (M2M Roaming Information) could contain subrange of IMSI defined for M2M

### 3.10 Additional Network type + Network Sharing (MOCN)

Some operators are sharing networks using MOCN that allows a network operator to provide access to a single radio access network by other operators. The shared MCC/MNC has to be configured in the GSMA PRD IR.21 [1] of the different operators, sharing the Radio Access Network.

This information is inside the section 4 (Routing Information) – “MCC-MNC codes used for MOCN”.

Key parameters specific to Network Sharing (MOCN) are:

- Section 1 (organization information) example – Telia Finland

Sender TADIG	TADIG	MCC-MNC	V/H	Network type
FINTF	FINTF	244-91	V/H	Terrestrial
FINTF	FINTF	244-36	V	Network Sharing (MOCN)

**Table 10 : Network type for Network Sharing Company**

- Section 4 (Routing information): E.212 number (MCC-MNC codes used for MOCN)

### 3.11 Additional Network type + Network Extension (same MCC-MNC) – Hosted networks

Some networks are extended for other services, but using the same MCC-MNC. So, in order to discriminate the 2 usages, Hosted Network section must be filled with an associated TADIG code and GT/IP/MSRN specific addresses.

A typical example is the extension of a network to provide maritime network, using the same MCC-MNC as the terrestrial network.

Network Extension Roaming principles are defined in GSMA PRD BA.21 [8] and GSMA PRD BA.46 [7].

Key parameters specific to Network Extension (same MCC-MNC) are:

- Section 1 (organization information) example - TIM Italy

Sender TADIG	TADIG	MCC-MNC	V/H	Network type
ITASI	ITASI	222-01	V/H	Terrestrial
ITASI	ITAGT	222-01	V	Non Terrestrial Network Extension (maritime)

**Table 11 : Network type for a company with Network extension**

- Section 22 (Hosted network): some specific parameters are listed below:
  - GT
  - IP
  - MSRN

### 3.12 Additional Network type + Network coverage Extension (new MCC-MNC)

Some operators have several MCC-MNC networks in order to cover one country, using the same TADIG code. Additional MCC-MNC could be seen as network coverage extension.

A typical example is the extension of a national coverage in some rural areas.

The additional MCC-MNC should be mentioned in the IP section 17 (Any *additional* MNC/MCC that may be sent RAI or LAI in GTP messaging from SGSNs/SGWs).

Key parameters specific to Network coverage Extension (new MCC-MNC) are:

- Section 1 (organization information) example – Orange France

Sender TADIG	TADIG	MCC-MNC	V/H	Network type
FRAF1	FRAF1	208-01	V/H	Terrestrial
FRAF1	FRAF1	208-02	V	Network Coverage Extension

**Table 12 : Network type for a company with Network coverage Extension**

- Section 17 (IP-Roaming and IP-Interworking Information):
  - Any additional MNC/MCC-RAI,
  - Any additional MNC/MCC-ULI

### 3.13 Network type mapping

The table hereafter summarizes the mapping of the different uses case and the GSMA PRD IR.21 [1] sections and parameters.

Section id	1	2	4	4	13	15	17	22	23
Network	Org	Net	E212	E164	NE	CAP	IP	Hosted	M2M
Terrestrial	M	M	M	M	O	O	O	-	-
Non-Terrestrial	M	M	M	M	O	O	O	-	-
Full MVNO	M	-	M	M	O	O	O	-	-
M2M Dedicated Operator	M	-	M	M	O	O	O	-	M
+ Multi user MCC-MNC	M	-	M	O	O	O	O	-	-
+ Multi network MCC-MNC	M	-	M	O	O	O	O	-	-

+ Light MVNO	-	-	-	Mvno attribute	Mvno attribute	Mvno attribute	Mvno attribute	-	-
+ M2M Integrated Solution	-	-	-	-	-	-	-	-	M
+ Network Sharing	M	-	Mocn mccmnc	-	-	-	-	-	-
+ Network Extension	M	-	-	-	-	-	-	M	-
+ Network Coverage Extension	M	-	-	-	-	-	RAI/LAI mccmnc	-	-

**Table 13: Network Type Mapping**

## 4 Use cases per roaming services

Those explanations are valid for IR.21 R18.

The following use cases are defined in this chapter per roaming services:

1. 2G/3G sunset
2. 4G (including 5G NSA)
3. VoIMS (VoLTE, VoNR)
4. MIoT
5. 5G SA
6. Emergency
7. Mission Critical

Note: At the end of the chapter, a table is summarizing all the impacted sections for the different use cases per roaming services.

### 4.1 2G/3G sunset

The 2G/3G sunset is defined in the GSMA PRD NG.121 [5].

Two major impacts on the VPLMN are identified:

- sunset in the Radio network (2G or 3G radio sunset) and
- sunset in the Core network (MSC (CS) sunset).

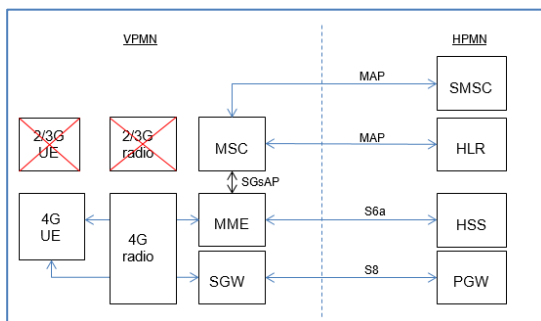

**Figure 3: 2G or 3G Radio sunset**

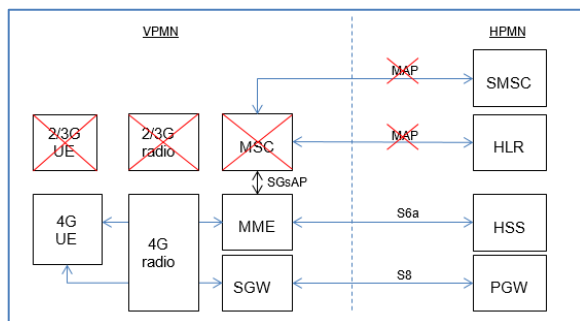

**Figure 3: MSC (CS) sunset**

MSC without 2G/3G radio is able to manage SMS over SGsAP.

IR.21 is affected for both the closure announcement and the implementation process.

**4.1.1 2G or 3G Radio sunset**

**4.1.1.1 Step 1: 2G or 3G Radio closure announcement**

The "Planned Closure Date" field (Section 2 – Service Status – Radio) must be completed to formally announce the sunset of 2G or 3G radio services.

Service Status and Planned Closure and availability (Radio network)			
Roaming Services supported as VPMN	Support	Planned closure date	Planned availability date
2G	Supported	DATE	
3G	Supported	DATE	

**Table 14: 2G or 3G Radio closure date information**

**4.1.1.2 Step 2: 2G or 3G Radio closure implementation**

The "Support (Y/N)" field (Section 2 – Service Status – Radio) must be set to “N” to formally implement the sunset of 2G or 3G radio services.

Service Status and Planned Closure and availability (Radio network)			
Roaming Services supported as VPMN	Support	Planned closure date	Planned availability date
2G	UnSupported	DATE	
3G	UnSupported	DATE	

**Table 15: 2G or 3G Radio closure date implementation**

Additionally, the 2G or 3G radio frequencies shall be removed from section 2.

Technology:	Frequency list	Coverage
2G-GSM	UnSupported	
3G-UTRA/FDD	UnSupported	
3G-UTRA/TDD	UnSupported	

**Table 16: Section 2 frequencies to be removed**

**4.1.1.3 No more MSC services**

Additionally, MSC is not active anymore for voice and some cleaning of MSC configuration shall be done on the following sections:

- Section 4 (Routing Info): removing MSRN ranges
- Section 15 (CAMEL): removing inbound part
- Section 30 (Emergency): removing CS fallback for “VPLMN technology Strategy for EC” parameter

**4.1.1.4 No more GPRS services**

Finally, GPRS is not active anymore and some cleaning of GPRS configuration shall be done on the following sections:

- Section 2 (Network): Service Status – Planned Closure and Availability (Core Network) – PS shall be set to “unsupported”
- Section 10 (MAP): removing Inbound (SGSN)
- Section 13 (Network elements information): removing SGSN nodes
- Section 16 (Packet Data Services): cleaning of 2G/3G QoS, GTP version, ...). APN list could be maintained if also applicable for 4G or 5G.

**4.1.2 MSC (CS) sunset**

**4.1.2.1 Step 1: MSC (CS) closure announcement**

The "Planned Closure Date" field (Section 2 – Service Status – Core) must be completed to formally announce the MSC sunset.

Service Status and Planned Closure and availability (Core network)			
Roaming Services supported as VPMN	Support	Planned closure date	Planned availability date
CS	Supported	DATE	

**Table 17:MSC Closure announcement**

**4.1.2.2 Step 2: MSC (CS) closure implementation**

The " Support (Y/N)" field (Section 2 – Service Status – Core) must be set to “N” to formally implement the MSC sunset (CS- Circuit Switched).

Service Status and Planned Closure and availability (Core network)			
Roaming Services supported as VPMN	Support	Planned closure date	Planned availability date
CS	UnSupported	DATE	

**Table 18:MSC Closure implementation**

Additionally, when the MSC is closed, SMSonNAS using SS7 is no more supported as VPLMN, impacting section 29 (SMS Roaming information):

SMS ITW-as VPLMN	
SMS Delivery mechanism	
SMS over NAS via SS7	UnSupported

**Table 19: Section 29 to be modified**

Moreover, some cleaning of MSC configuration shall be done on the following sections:

- Section 10 (MAP): removing Inbound (MSC/VLR)
- Section 13 (Network elements information): removing MSC nodes

## 4.2 4G opening

4G Roaming is defined in the GSMA PRD IR.88 EPS Roaming Guidelines [3].

Its main purpose is to provide a standardized view on how operators around the world deploy interoperable, secure, and consistent roaming services for 4G customers.

Note: LTE (Long Term Evolution) abbreviation is used to describe 4G core network

### 4.2.1 4G support (Section 2)

#### 4.2.1.1 4G Support on Radio Network

The "Support (Y/N)" field (Section 2 – Service Status – Radio) must be set to “Y” to formally announce the support of 4G.

Service Status and Planned Closure and availability (Radio network)			
Roaming Services supported as VPMN	Support (Y/N)	Planned closure date	Planned availability date
4G	Y		Planned date

**Table 20: 4G Support on Radio Network**

The frequency list used in 4G must be filled as the 4G -E-UTRA:

Technologies and Frequencies		
Technology	Frequency list	Coverage
4G-E-UTRA	Frequency list: Band, Duplex Mode and Frequency in MHz	

**Table 21: Frecuency list in 4G**

#### 4.2.1.2 4G Support on Core Network

The " Support (Y/N)" field (Section 2 – Service Status – Core) must be set to “Y” for “EPC” (4G)

Service Status and Planned Closure and availability (Core network)			
Roaming Services supported as VPMN	Support (Y/N)	Planned closure date	Planned availability date
EPC	Y		Planned date

**Table 22: 4G Support on Core Network**

### 4.2.2 4G Network Elements (Section 13)

The network elements (Section 13) used for EPC (MME, SGW, PGW, PCRF and HSS) node shall be filled in the table below :

Node Type	GT Address or GT Address Range	IP Address or IP Address Range (IPv4)	IP Address or IP Address Range (IPv6)	Vendor Info	UTC Time Offset

**Table 22: 4G Network Element Table**

### 4.2.3 4G Roaming Signaling Support on Radio Network Allowing (Section 20)

The IPX interconnection information, the Roaming EPC Realms, the FQDN Diameter Edge Agents and the S6a/S6d/MAP IWF (Section 20) shall be filled in the table below:

IPX Interconnection Information		
IPX Diameter Provider Names		
Date of Launch		
Date of Closure		
IP addresses of Diameter Agents	Primary	Secondary
Realms used by IPX DA		
Diameter architecture option 5 or 6		
- Option 5: Direct between network elements		
- Option 6: Via Diameter Routing Agent (DRA)		

**Table 23 : IPX interconnection information Section**

Roaming Interconnection	
Diameter:	
EPC Realm(s)/domain name(s) used for Roaming purpose	epc.mnc<MNC>.mcc<MCC>.3gppnetwork.org
FQDN of the Diameter Edge Agent	
Primary IP addresses of DEA FQDN	
Secondary IP addresses of DEA FQDN	

S6a (Diameter base protocol between MME and HSS)	
Is S6a supported without IWF?	[Yes/No]
Is IWF available to allow support of inter-PMN MAP interface for connection towards HSS?	[Yes/No]
Is IWF available to allow support of inter-PMN MAP interface for connection towards MME?	[Yes/No]

S6d (Diameter base protocol between S4-SGSN and HSS)	
Is S6d used for legacy SGSN?	[Yes/No]

S9 (Diameter base protocol between hPCRF - vPCRF)	
Is S9 used?	[Yes/No]

**Table 24: Roaming interconnection information**

### 4.2.4 4G Roaming Voice (Section 20)

The voice interworking model (Section 20) used in shall be filled in the table below:

- If 4G roaming is opened without VoLTE roaming, Voice ITW shall be CSFB.
- If VoLTE roaming (see § VoLTE opening) is opened, Voice ITW shall be IMS.

Voice ITW	
IMS / CSFB / other	CSFB (4G roaming) or IMS (VoLTE roaming)

**Table 25: 4G roaming is opened without VoLTE roaming**

Roaming CS FallBack	
Roaming CS FallBack method?	Roaming Retry (MTRR) Roaming Forward (MTRF) Not supported

**Table 26: If VoLTE roaming is opened**

**4.2.5 4G Roaming Information (Section 20)**

The Home/Visited PMN Information for LTE Roaming Only shall be set to “Yes/No” if supported as specified in the table below:

Home PMN Information For LTE Roaming Agreement Only	
Is LTE-only roaming supported?	[Yes/No]

**Table 27: HPMN info for LTE**

Visited PMN Information For LTE Roaming Agreement Only	
Is LTE-only roaming supported?	[Yes/No]

**Table 28: HPMN info for LTE**

If any *additional* MNC/MCC (that is different to the MNC/MCC in the E.212 field) shall be sent in the Visited PLMN Id AVP in Diameter ULR or AIR messages, they should be filled in the table below on section 20 (typical examples are MOCN or Network coverage Extension):

Any <i>additional</i> MNC/MCC (that is different to the MNC/MCC in the E.212 field) that may be sent in the Visited PLMN Id AVP in Diameter ULR or AIR messages		
Visited PLMN Id AVP 1407	MCC (3 digit)	MNC (2 or 3 digit)

**Table 29: Additional IMSIs**

**4.2.6 4G QoS profile (Section 20)**

The information related to different QoS profiles with one mandatory profile for the default QoS shall be filled in the table below (Section 20).

Standard QCI shall be defined based on IR.88 [3] definition in the following paragraph/tables:

- § 7.1 (QoS Parameters definition)
- Table 15 (Standardize QCI characteristics) and
- Table 16 (Roaming QoS values)

The “LTE QoS Profiles” shall specify the QoS profile from the HPMN perspective, while the “Control of QoS parameters within the VPMN MME/S4-SGSN” defines the QoS control from the VPMN side.

List of LTE QOS profiles				
Profile name				
QCI				
ARP Priority Level				
ARP Pre-emption vulnerability				

ARP Pre-emption capability				
Maximum Bit Rate Uplink				
Maximum Bit Rate Downlink				
Guaranteed bit rate uplink				
Guaranteed bit rate downlink				

**Table 30: 4G QoS profile**

Control of QoS parameters within the VPMN MME/S4-SGSN		
Service name		
Service supported	(Yes/No)	
Bearer Type		
QCI	Allowed QCI Value List	
	Remap or not if QCI received from HPMN does not meet requirement	
	Remap Value	
ARP	Allowed ARP-PL Value List	
	Allowed ARP Preemption Vulnerability List	
	Allowed ARP Preemption Capability List	
	Downgrade or not if ARP received from HPMN does not meet requirement	
	Downgrade Value	
APN AMBR	Allowed Max-Requested-Bandwidth for uplink	
	Allowed Max-Requested-Bandwidth for downlink	
Maximum Bit Rate	Allowed Maximum Value for uplink(kbps)	
	Allowed Maximum Value for downlink(kbps)	
Guaranteed Bit Rate	Allowed Maximum Value for uplink(kbps)	
	Allowed Maximum Value for downlink(kbps)	
Comments		

**Table 31: QoS parameters within the VPMN MME/S4-SGSN**

The " Support (Yes/No)" field (Section 20) must be set to IPv6 connectivity Information for MME, SGW, PGW:

IPv6 Connectivity Information		Supported (Yes/No)
MME	IPv6 PDN Type	[Yes/No]
	IPv4v6 PDN Type	[Yes/No]
SGW	IPv6 PDN Type	[Yes/No]
	IPv4v6 PDN Type	[Yes/No]
PGW	IPv6 PDN Type	[Yes/No]
	IPv4v6 PDN Type	[Yes/No]

**Table 32: Ipv6 connectivity information**

**4.2.7 5G NSA Roaming (Section 20)**

5G NSA Roaming is similar to 4G Roaming in term of interface and procedures, however some supported 5G NSA parameters shall be set if 5G NSA is supported in section 20:

5G Early Drop support		
	AS HPMN (outbound)	As VPMN (inbound)
5G NSA supported	Y/N	Y/N
DNS PGW NAPTR includes +nc-nr	Y/N	Y/N
NSA Option for EN-DC (VPMN only)		3, 3A, 3X
ARD set with feature list AVP#27	Y/N	
Restrict access for NR when HSS does not set the feature list AVP#27		Y/N

**Table 33: 5G NSA parameters**

**4.2.8 4G SMS (Section 29)**

The SMS over NAS via Diameter " Support (Y/N)" shall be set to "Y/N" for SMS delivery via Diameter in 4G for VPLMN and HPMN, according to the configuration.

SMS ITW-as VPLMN	
SMS Delivery mechanism	
SMS over NAS via Diameter	Y/N

**Table 34: SMS over NAS via Diameter for VPMN**

SMS ITW-as HPLMN	
SMS Delivery mechanism	
SMS over NAS via Diameter	Y/N

**Table 35: SMS over NAS via Diameter for HPMN**

**4.3 VoIMS opening**

VoIMS (VoLTE, VoNR) is covered in the GSMA PRD IR.65 [15] and VoLTE Implementation Guide.

**4.3.1 VoIMS opening (Section 2)**

In IR.21, VoIMS service is configured in section 2 (Network).

Two different tables are defined to open VoIMS in VPMN (Inbound) or in HPMN (Outbound):

**Service Status and Planned Closure and availability (Core network)**

Roaming Services supported as VPMN	Support (Y/N)	Planned closure date	Planned availability date
CS			
PS			
EPC			
VoIMS	Y		Planned date
MCX			
5G SA			

**Table 36: VoIMS Supporting table**

**4.3.2 QoS for IMS APN (Section 20)**

In Section 20 (LTE Roaming), two fields related to the well-known IMS APN are defined: “LTE QoS Profiles” and “Control of QoS parameters within the VPMN MME/S4-SGSN.” The “LTE QoS Profiles” shall specify the QoS profile from the HPMN perspective, while the “Control of QoS parameters within the VPMN MME/S4-SGSN” defines the QoS control from the VPMN side.

**4.3.3 VoIMS Roaming (Section 26)**

IR.21 also includes a dedicated Section 26 (VoIMS Roaming Information) specifically for VoIMS roaming.

**4.3.3.1 Supported VoIMS roaming architectures**

The supported VoIMS architectures shall be clearly indicated for both S8HR (EPC) and N9HR (5GC), for both HPMN and VPMN. These architectures are defined in GSMA PRD IR.65 [15].

VoIMS Roaming architectures supported as VPMN	
S8HR (EPC-4G)	[Yes/No]
VoIMS Roaming architectures supported as HPMN	
S8HR (EPC-4G)	[Yes/No]
VoIMS Roaming architectures supported as VPMN	
N9HR (5GC)	[Yes/No]
VoIMS Roaming architectures supported as HPMN	
N9HR	[Yes/No]

**Table 37: VoIMS architectures Information table**

Additionally, support of GTT-IP shall be configured:

VoIMS Roaming service supported as VPMN	
GTT-IP	[Yes/No]
VoIMS Roaming service supported as HPMN	
GTT-IP	[Yes/No]

**Table 38: GTT-IP Support information table**

**4.3.3.2 Mobility and Voice Continuity**

The supported mobility and voice continuity technologies - such as SRVCC (defined in GSMA PRD IR.64 [16]) or the indication “Not supported” shall be specified for both HPMN and VPMN.

**4.3.3.3 S8HR/N9HR Roaming Constraints as VPMN (Inbound)**

The deployment status of Lawful Interception (refer to 3GPP TS 33.107 [17]) shall be clearly stated in order for HPMN to de-activate ciphering encryption.

Lawful Interception / Data retention	
Does VPMN require encryption deactivation by HPMN for IMS procedures	Yes/No

**Table 38: Lawful Interception Support information table**

The name of the EPS QoS profile dedicated to the well-known IMS APN, as defined in Section 20 (LTE Roaming – LTE QoS Profiles), shall be specified in the “EPS QoS to be enforced” field.

EPS QoS to be enforced	
Maximum QoS profile supported for “ims” well known APN	<EPS QoS profile> name described in section 20 (LTE Roaming Information) and dedicated to “ims” APN.

**Table 38: EPS QoS to be enforced table**

If the VoIMS emergency call is opened, then Section 30 shall also be updated (refer to § 5.6 Emergency service opening).

**4.3.4 IMS SMS (Section 29)**

The SMS over IMS " Support (Y/N)" shall be set to “Y/N” for SMS delivery via IP for VPLMN and HPMN, according to the configuration.

SMS ITW-as VPLMN	
SMS Delivery mechanism	
SMS over IP	Y/N

SMS ITW-as HPLMN	
SMS Delivery mechanism	
SMS over IP	Y/N

**Table 39: SMS over IMS information table**

**4.4 MlIoT opening**

MlIoT Roaming is defined in the GSMA PRD NG.117 MlIoT Roaming Guidelines [14]. Its main purpose is to provide a standardized view on how operators around the world deploy interoperable, secure, and consistent roaming services for MlIoT customers.

Note: MlIoT is mainly composed of 2 technologies (LTE-M and NB-IoT), based on 4G network.

#### 4.4.1 MloT support (Section 2)

The "Support (Y/N)" field (Section 2 – Service Status – Radio) must be set to "Y" to formally announce the support of MloT.

Service Status and Planned Closure and availability (Radio network)			
Roaming Services supported as VPMN	Support (Y/N)	Planned closure date	Planned availability date
MloT- LTE-M	Y		Planned date
MloT- NB-IoT	Y		Planned date

**Table 40: MloT support**

The frequency list used in 4G must be filled as the 4G -E-UTRAN-MloT:

Technologies and Frequencies		
Technology	Frequency list	Coverage
4G-E-UTRAN-MloT-LTE-M	Frequency list: Band, Duplex Mode and Frequency in MHz	
4G-E-UTRAN-MloT-NB-IoT	Frequency list: Band, Duplex Mode and Frequency in MHz	
4G-MloT-NB-IOT Deployment Mode	Group element containing the list of NB-IoT specific deployment options	

**Table 41: Frequency list in 4G**

#### 4.4.2 LPWA Roaming (Section 27)

##### 4.4.2.1 LWPA roaming – LTE-M

The following parameters need to be fulfilled for LTE-M, as a HPMN or VPMN.

LTE-M Services supported as HPMN (outbound)	
IP version	IPv4, IPv6, Dual-stack
Data transport via control plane	[Yes/No]
Data transport via user plane	[Yes/No]
NIDD support	[Yes/No]
NIDD via SCEF	[Yes/No]
NIDD via PgW	[Yes/No]
Power Saving Mode / PSM	[No, Static, Dynamic]
Extended Discontinuous Reception / eDRX	[No, Static, Dynamic]
SMS	[Yes/No]
SMS buffering period	
VoLTE over LTE-M	[Yes/No]
IPX GTP Firewall	[Yes/No]
IPX Firewall GTP Idle timer value	
LTE-M Services supported as VPMN (inbound)	
IP version	IPv4, IPv6, Dual-stack
Data transport via control plane	[Yes/No]
Data transport via user plane	[Yes/No]
NIDD support	[Yes/No]
NIDD via SCEF	[Yes/No]
NIDD via PgW	[Yes/No]
Release Assistance Indication Rel 14	[Yes/No]
Power Saving Mode/PSM	[No, Static, Dynamic]
PSM T3324 timer minimum value	
PSM T3324 timer maximum value	
PSM extended T3412 timer minimum value	
PSM extended T3412 timer maximum value	
PSM packet buffering support	[Yes/No]

PSM packet buffering volume	
DRX cycle timer	
Extended Discontinuous Reception / eDRX	[Yes/No]
eDRX cycle timer minimum value	
eDRX cycle timer maximum value	
eDRX PTW minimum value	
eDRX PTW maximum value	
eDRX packet buffering support	[Yes/No]
eDRX packet buffering volume	
Connected Mode Mobility / CMM	[Yes/No]
RRC Inactivity timer duration	
Coverage Enhancement Mode A / CE	[Yes/No]
RRC Inactivity timer duration for Mode A	
Coverage Enhancement Mode B / CE	[Yes/No]
RRC Inactivity timer duration for Mode B	
SMS	[Yes/No]
SMS buffering period	
VoLTE over LTE-M	[Yes/No]
IPX GTP Firewall	[Yes/No]
IPX Firewall GTP Idle timer value	
UE Power class support	Class 3, Class 5

**Table 42: LTE-M parameters table**

#### 4.4.2.2 LWPA roaming – NB-IoT

The following parameters need to be fulfilled for NB-IoT, as a HPMN or VPMN.

NB-IoT Services supported as HPMN (outbound)	
IP version	IPv4, IPv6, Dual-stack
Data transport via control plane	[Yes/No]
Data transport via user plane	[Yes/No]
NIDD support	
NIDD via SCEF	[Yes/No]
NIDD via PgW	[Yes/No]
Power Saving Mode / PSM	[No, Static, Dynamic]
Extended Discontinuous Reception / eDRX	[No, Static, Dynamic]
SMS	[Yes/No]
SMS buffering period	
IPX Firewall GTP Idle timer value	
NB-IoT Services supported as VPMN (inbound)	
IP version	IPv4, IPv6, Dual-stack
Data transport via control plane	[Yes/No]
Data transport via user plane	[Yes/No]
NIDD support	
NIDD via SCEF	[Yes/No]
NIDD via PgW	[Yes/No]
Release Assistance Indication Rel 13	[Yes/No]
Release Assistance Indication Rel 14	[Yes/No]
Power Saving Mode / PSM	[No, Static, Dynamic]
PSM T3324 timer minimum value	
PSM T3324 timer maximum value	
PSM extended T3412 timer minimum value	
PSM extended T3412 timer maximum value	
PSM packet buffering support	[Yes/No]
PSM packet buffering volume	
DRX cycle timer	
Extended Discontinuous Reception / eDRX	[No, Static, Dynamic]
eDRX cycle timer minimum value	
eDRX cycle timer maximum value	
eDRX PTW minimum value	
eDRX PTW maximum value	
eDRX packet buffering support	[Yes/No]
eDRX packet buffering volume	
RRC Inactivity timer duration	
Coverage Extension	[Yes/No]
RRC Inactivity timer duration for CE1	
RRC Inactivity timer duration for CE2	
RRC Inactivity timer duration for CE3	
SMS	[Yes/No]
SMS buffering period	
IPX GTP Firewall	[Yes/No]
IPX Firewall GTP Idle timer value	
UE Power class support	Class 3, Class 5, Class 6

**Table 43: NB-IoT parameters table**

**4.4.3 MloT SMS (Section 29)**

The SMS over NAS shall be recommended for MloT roaming traffic and could be defined in the following tables.

SMS ITW-as VPLMN	
SMS Delivery mechanism	
SMS over NAS via SS7	Y/N
SMS over NAS via Diameter	Y/N
SMS over NAS via HTTPs	Y/N

SMS ITW-as HPLMN	
SMS Delivery mechanism	
SMS over NAS via SS7	Y/N
SMS over NAS via Diameter	Y/N
SMS over NAS via HTTPs	Y/N

**Table 44: MloT SMS support table**

**4.4.4 M2M (Section 23)**

For MloT traffic, specific IMSI subranges could be used and could be configured in section 23.

List of Subrange IMSI		
Subrange IMSI	Description	Example

**Table 45: Specific IMSI for MloT traffic table**

**4.4.5 Organisation (Section 1)**

For MloT traffic, specific M2M network (defined in §3) could be used and could be configured in section 1.

**TADIG summary**

TADIG	MCC/MNC	VPMN/HPMN	Network Type
			M2M Dedicated Operator (M2MDO)
			M2M Integrated Solution (M2MIS)

**Table 46: Tadig Information table**

### 4.5 5G SA opening

5G SA Roaming is defined in the GSMA PRD NG.113 5GS Roaming Guidelines [4].

Its main purpose is to provide a standardized view on how 5G Core (5GC) networks interoperate for roaming, covering architecture, signalling, services (data, voice, SMS, emergency) and contact.

#### 4.5.1 5G SA support (Section 2)

It primarily addresses roaming when using NR radio bearers connected to a 5GC.

##### 4.5.1.1 5G Support on Radio Network

The "Support (Y/N)" field (Section 2 – Service Status – Radio) must be set to “Y” to formally announce the support of 5G New Radio (NR).

Service Status and Planned Closure and availability (Radio network)			
Roaming Services supported as VPMN	Support (Y/N)	Planned closure date	Planned availability date
5G-NR	Y		Planned date

**Table 47: 5G Support on Radio Network Table**

The frequency list used in 5G-NR must be filled as the 5G-NR:

Technologies and Frequencies		
Technology	Frequency list	Coverage
5G-NR	Frequency list: Band, Duplex Mode and Frequency in MHz	

**Table 48: Frequency list used in 5G-NR information Table**

##### 4.5.1.2 5G Support on Core Network

The "Support (Y/N)" field (Section 2 – Service Status – Core) must be set to “Y” for “5G SA”5G

Service Status and Planned Closure and availability (Core network)			
Roaming Services supported as VPMN	Support (Y/N)	Planned closure date	Planned availability date
5G SA	Y		Planned date

**Table 48: 5G Support on Core Network Table**

#### 4.5.2 5G SA signalling (Section 28)

All signalling between the Visited PLMN (VPLMN) and the Home PLMN (HPLMN) is carried over an HTTP/2 APIs, protected end-to-end by the SEPP using the N32 interface consisting of two interfaces:

- N32-c: Handles certificate exchange, security policies, and validation of allowed APIs.
- N32-f: Transports all 5G SBA signalling across PLMNs (encrypted + topology hiding).

Each SEPP (representing the MNO) shall be defined based on the next table, defining the following parameters:

SEPP information					
SEPP model	MCC/MNC List	Well-known FQDN	SEPP FQDN	IPX provider	SEPP-N32 parameters

**Table 49: SEPP Parameters table**

The following parameters have to be fulfilled:

- Different SEPP model could be defined (1/2/3/4), associated to a (list of) MCC/MNC as defined in NG.113, § 4.2 [4].
- A well-known FQDN (associated to the different models) is associated to the SEPP.
- SEPP FQDN could be found via a DNS NAPTR query or using IR.21 parameter, compliant with one of the four 5G SA models.
- An IPX provider (for model 2,3 or 4) could be provided optionally.
- Finally, some SEPP-N32 parameters are added for protocol support, and parameters support.

Typical examples for SEPP FQDN and well-known FQDN are listed hereafter for the different models:

##### Model 1 bilateral

- well-known FQDN: sepp.5gc.mnc001.mcc010.3gppnetwork.org
- SEPP FQDN: sepp-id.sepp.5gc.mnc001.mcc010.3gppnetwork.org

##### Model 2.2 - Hosted SEPP

- well-known FQDN: sepp.5gc.mnc001.mcc010.3gppnetwork.org
- SEPP FQDN: sepp-id.sepp.5gc.mnc001.mcc010.carrier-id.ipxnetwork.org

##### Model 2.3 – Group SEPP – group

- well-known FQDN: sepp.5gc.mnc001.mcc010.3gppnetwork.org
- SEPP FQDN: <SEPP-ID>.sepp.5gc.group-<text>.<GROUP-SEPP-PROVIDER-ID>.ipxnetwork.org

##### Model 3-Service Hub

- well-known FQDN: sepp.5gc.hub.<ServiceHub-ID>.ipxnetwork.org
- SEPP FQDN: SH.<SEPP-ID>.sepp.5gc.hub.<ServiceHub-ID>.ipxnetwork.org

**Model 4-Roaming Hub**

- well-known FQDN: sepp.5gc.hub.<RoamingHub-ID>.ipxnnetwork.org
- SEPP FQDN: RH.<SEPP-ID>.sepp.5gc.hub.<RoamingHub-ID>.ipxnnetwork.org

**4.5.3 5G SA Data (Section 28)**

It describes the 5GS roaming architecture, including the Home Routed (HR) and Local Break Out (LBO) models, and the interfaces involved, notably the N9 interface between the HPMN and the Visited Public Mobile Network (VPMN) and 5G QoS profile.

For 5G data roaming, 2 options (LBO/HR) could be foreseen:

Data 5G Roaming Architectures Supported as VPMN	
N9HR	Y/N
N9LBO	Y/N

**Table 50: 5G Roaming Architectures for VPMN information table**

Data 5G Roaming Architectures Supported as HPMN	
N9HR	Y/N
N9LBO	Y/N

**Table 51: 5G Roaming Architectures for HPMN information table**

List of 5GS QoS profiles				
Profile name				
5QI				
ARP Priority Level				
ARP Pre-emption vulnerability				
ARP Pre-emption capability				
Maximum Bit Rate Uplink				
Maximum Bit Rate Downlink				
Guaranteed bit rate downlink				
Guaranteed bit rate uplink				

**Table 52: 5GS QoS information table**

**4.5.4 5G SA for Voice (Section 26)**

For voice only Home Routing architecture could be foreseen and should set to Yes for VoIMS Roaming information as shown in the table below:

VoIMS Roaming architectures supported as VPMN	
N9HR	Y/N
VoIMS Roaming architectures supported as HPMN	
N9HR	Y/N

**Table 53: 5G SA for Voice support information table**

**4.5.5 5G SA for Voice Emergency (Section 30)**

Finally for Voice, the emergency information (VPLMN technology strategy for EC) should be set to VoNR and the AMF should set to Yes if he announces the Emergency number list toward inbound roamer's UE as shown in the table below:

Emergency calls	
VPLMN technology Strategy for EC	VoNR
AMF announce the Emergency number list toward inbound roamer's UE?	Y/N

**Table 54: 5G SA for Voice Emergency Support table**

**4.5.6 5G SA SMS (Section 29)**

The SMS over NAS via HTTPs " Support (Y/N)" shall be set to "Y/N" for SMS delivery via HTTPs in 5G SA for VPLMN and HPMN, according to the configuration.

SMS ITW-as VPLMN	
SMS Delivery mechanism	
SMS over NAS via HTTPs	Y/N

SMS ITW-as HPLMN	
SMS Delivery mechanism	
SMS over NAS via HTTPs	Y/N

**Table 55: SMS over NAS via HTTPs Support table**

**4.5.7 5G SA contact (Section 21)**

The contact information should be filled in with the contact persons for certificates and key management used for security aspects.

Contact person(s) for Certificates and Key management	Person Name or Team Name	Tel.	Email

**Table 56: 5G SA contact detail table**

GSMA has provided a new RAEX repository for root certificates, or alternatively subordinate (intermediate) certificates used to sign leaf (SEPP certificate) accessible via this link:

[https://www.raextools.com/raextools/#CERTIFICATE\\_REPOSITORY/CERTIFICATES](https://www.raextools.com/raextools/#CERTIFICATE_REPOSITORY/CERTIFICATES)

Depending on the model used, MNOs (model 1), IPX providers (model 2 or 3), and Roaming Hubs (model 4) upload, store distribute, publish and revoke their Root/Sub certificates via the RAEX Tools.

**4.6 Emergency service opening**

Emergency service is defined in the GSMA PRD NG.119 [11].

Its main purpose is to provide a standardized view on how emergency services (call, ecall, GTT/RTT, AML) are implemented for roaming.

**4.6.1 Emergency Call (section 30)**

The propose of the next table is to indicate which technology is supported for emergency voice call (CS Fallback, VoLTE , VoNR)

Emergency calls	
VPLMN technology Strategy for EC	VoNR VoLTE CS Fallback

**Table 57: Emergency Call technology Support table**

This information should be updated to reflect network evolution. After 2G/3G closure CS Fallback is no more supported and should be then removed from the list of technology

A crucial aspect of roaming VoLTE/VoNR is to make the device aware of the local emergency numbers used in the visited network. By example, this information can be utilized by the home network to reject local emergency calls using SIP 380 as described in GSMA PRD NG.119 [11]. Additionally, device manufacturers can use this data to update the list of emergency numbers stored in the device, based on the customer's current location.

The next table will be completed with the following information:

- Number Maximum 15 digits.
- Name of emergency service corresponding to the number
- URN information should follow sub-clause 9.9.3.37A of 3GPP TS 24.301

Find example of table completion

List of Local Emergency Numbers in use at the VPMN	Number	Service	URN Information
	112 100	General emergency call Fire brigade	urn:service:sos urn:service:sos.fire

**Table 58: Emergency Call local number list**

To enhance the device's awareness of local emergency numbers in use, the serving network can download additional emergency numbers, particularly local ones, to the UE. This enables the UE to detect emergency sessions more effectively.

The following table indicates whether the visited MME (4G) and/or the AMF (5G) support announcing emergency numbers to inbound roamers—"Yes" for supported, "No" for not supported

MME announces the Emergency number list toward inbound roamer's UE?	[Yes/No]
AMF announces the Emergency number list toward inbound roamer's UE?	[Yes/No]

**Table 59: MME/AMF Emergency announcement support**

According to local regulations, the network must reject unauthenticated IMS emergency calls and/or IMS emergency calls made without a UICC.

<b>VPLMN accepts unauthenticated IMS Emergency call?</b>	[Yes/No]
<b>VPLMN accepts IMS Emergency call without UICC?</b>	[Yes/No]

**Table 59: Acception of messages without a UICC information table**

**4.6.2 GTT-IP / RTT**

With the introduction of IMS in 4G, new services such as Global Text Telephony over IP (GTT-IP) / Real Time Text (RTT) to emergency centre (PSAP) became available. These services are especially important for people who are Deaf, Deafblind, or Hard of Hearing, as they allow real-time communication and access to emergency services. Depending on local regulations, operators may also be required to provide access to emergency centre for inbound roamers.

In the next table will indicate if network natively support RTT

<b>Real Time Text (RTT)</b>	
VPMN technology natively support for GTT-IP / RTT to emergency center	[Yes/No]

**Table 60: Support RTT information table**

Furthermore, the operator must specify which emergency numbers support RTT (Real-Time Text) and the associated services.

As an example: Number:112 for access to Service: General emergency services.

<b>List of Numbers to access the Emergency Center via GTT-IP / RTT</b>	<b>Number</b>	<b>Service</b>
	112	General emergency service

**Table 61: emergency numbers support RTT detailed table**

**4.6.3 eCall**

eCall is an in-vehicle emergency call to 112 that can be triggered automatically by in-vehicle sensors or manually by passengers. It sends a Minimum Set of Data (MSD) and opens an audio channel between the vehicle and the eCall PSAP using public mobile networks.

While eCall works exclusively on 2G/3G, NG eCall is based on 4G and 5G. Depending on local regulations, operators may also be required to support eCall services for both local users and inbound roamers. For further information regarding eCall, refer to GSMA PRD NG.119 [11].

The following table aims to determine if the network does not support eCall: None.

If eCall is supported, the specific technology should be identified as either eCall and/or NGeCall.

This information should be updated to reflect network evolution. After the closure of 2G/3G, eCall should be removed from the list of supported technologies.

eCall	
VPMN technology strategy for eCall	None eCall NGeCall

**Table 61: eCall support table**

**4.6.4 AML**

Advanced Mobile Location (AML) is a technology that automatically transmits a caller’s precise location to emergency services when an emergency call (e.g., to 112 or 911) is made from a mobile device. ETSI has defined two mechanisms for transmitting location information: via SMS or via an HTTP connection. Depending on local regulations, operators may be required to support AML services for both local customers and inbound roamers. For further information regarding AML, refer to GSMA PRD NG.119 [11].

The following table aims to determine if the network does not support AML: None. If AML is supported, the technology used to transmit location information to PSAPs should be specified as either SMS and/or HTTP.

Advance Mobile Location (AML)	
VPMN technology strategy for AML	None SMS HTTP

**Table 62: Advanced Mobile Location Support table**

Furthermore, if AML is supported on the network, it is important to specify which emergency number and service AML is associated with.

For example: Number: 112 for access to General Emergency Services.

List of emergency numbers that trigger the sending of location information via AML	Number	Service
	112	General emergency Service

**Table 61:Emergency Number and AML Service Support table**

**4.7 Mission Critical service opening**

Mission Critical Services have been defined by the 3GPP and have grown in the specifications since its start in the release13. Since then, a need has been recognized for Public Safety Agencies (PSAs) to enhance mission critical communication capabilities by leveraging on new technologies, i.e. LTE radio access technology, enhanced MBMS (Multimedia Broadcast/Multicast Service), IP Multimedia Subsystem (IMS) platform as well as on the new set of 5G services.

MCX roaming guidelines could be found in NG.150 [12] and is deployed on 4G or 5G networks

**4.7.1 MCX opening (VPMN or HPMN) (Section 2)**

In IR.21, MCX service is configured in section 2 (Network).

2 different tables are defined to open MCX in VPMN (Inbound) or in HPMN (outbound):

Service Status and Planned Closure and availability (Core network)			
Roaming Services supported as VPMN	Support (Y/N)	Planned closure date	Planned availability date
CS			
PS			
EPC			
VoIMS			
MCX	Y		Planned date
5G SA			

**Table 62:MCX opening in HPMN (outbound)**

Service Status and Planned Closure and availability (Core network)			
Roaming Services supported as HPMN	Support (Y/N)	Planned closure date	Planned availability date
CS			
PS			
EPC			
VoIMS			
MCX	Y		Planned date
5G SA			

**Table 63:MCX opening in VPMN (Inbound)**

#### 4.7.2 MCX in 4G (Section 20)

MCX could be implemented first in 4G roaming.

MCX will request specific QoS parameters which will be defined in section 20 (LTE) - parameter "List of LTE QOS profiles", supported by the VPMN.

Typical example of "List of LTE QOS profiles" for MCX are listed hereafter:

Profile name	QC I	ARP Priority Level	ARP Pre-emption vulnerability	ARP Pre-emption capability	Maximum Bit Rate UL	Maximum Bit Rate DL	Guaranteed bit rate UL	Guaranteed bit rate DL
MCX signalling	69	1	Enabled	Enabled				
MCPTT	65	2	Enabled	Enabled	50 kbps	50 kbps	50 kbps	50 kbps
MCVIDEO	67	3	Enabled	Enabled	3500 kbps	3500 kbps	384 kbps	384 kbps
MCDATA	70	4	Enabled	Enabled				

**Table 64: List of LTE QOS profiles**

#### 4.7.3 MCX in 5G (Section 28)

MCX could be implemented in a second step in 5G roaming.

MCX will request specific QoS parameters which will be defined section 28 (5GSA) - parameter "List of 5GS QOS profiles", supported by the VPMN.

#### 4.8 Service type mapping

The table hereafter summarizes the mapping of the different service uses case and the GSMA PRD IR.21 [1] sections.

Section Id	2	13	20	21	23	24	26	28	29	30
Service	Net	NE	LTE	Contact	M2M	LWPA	VoIMS	5G	SMS	Emerg
2G/3G sunset	M								O	M
4G	M	M	M						O	
VoIMS	M		M				M		O	M
MIoT	M				O	M			O	
5G SA	M			M			M	M	O	M
Emergency										M
MCX	M		O					O		

M: Mandatory O: Optional

**Table 65: Service Type mapping table**

## 5 Additional guidelines per section

### 5.1 Messaging interworking opening

SMS/MMS interworking are defined in IR.21 [2]

- Section 12 for SMS (new in R18)
- Section 18 for MMS

#### 5.1.1 SMS interworking (Section 12)

This table is used to identify SMS hub provider (Name) used by the MNO. Depending on the network owner (e.g. MNO, MVNO,...), multiple SMS hub providers could be used. SMS hub Provider Name will be completed using a drop down list to assure that name is the correct one.

List of SMS IW Hub Provider	SMS IW Hub Provider Name	Network Owner

**Table 66: SMS IW Hub Provider Table**

#### 5.1.2 MMS interworking (Section 18)

This table is used to identify MMS hub provider used by the MNO

MMS Element Data						
Domain name of MMSC	IP Address Range for MMSC	Max. size of MMS allowed	Delivery Report allowed? (Y/N)	Read Report allowed? (Y/N)	IP address(es) of Incoming MTA	IP address(es) of Outgoing MTA
List of MMS IW Hub Provider		MMS IW Hub Provider Name		MMS IW Hub Provider GT Address		

**Table 67: MMS hub provider Identification Table**

### 5.2 Contacts

It is recommended to use team name for contacts, preferred to person.

## 6 Additional guidelines for roaming hub

For further studies

Pointing to GSMA PRD IR.85 [10]

## Annex A Document Management

### Document History

Version	Date	Brief Description of Change	Approval Authority	Editor / Company
1.0	22/04/2026	First version	ISAG	Marc Balon (Orange)

### Other Information

Type	Description
Document Owner	NG
Editor / Company	Marc Balon (Orange)

It is our intention to provide a quality product for your use. If you find any errors or omissions, please contact us with your comments. You may notify us at [prd@gsma.com](mailto:prd@gsma.com)

Your comments or suggestions & questions are always welcome.