



# LBS Roaming and Inter-working Guidelines

## Version 3.0.0

### 12 February 2010

*This is a Non-binding Permanent Reference Document of the GSMA*

---

#### **Security Classification: Non-confidential**

Access to and distribution of this document is restricted to the persons permitted by the security classification. This document is confidential to the Association and is subject to copyright protection. This document is to be used only for the purposes for which it has been supplied and information contained in it must not be disclosed or in any other way made available, in whole or in part, to persons other than those permitted under the security classification without the prior written approval of the Association.

#### **Copyright Notice**

Copyright © 2015 GSM Association

#### **Disclaimer**

The GSM Association ("Association") makes no representation, warranty or undertaking (express or implied) with respect to and does not accept any responsibility for, and hereby disclaims liability for the accuracy or completeness or timeliness of the information contained in this document. The information contained in this document may be subject to change without prior notice.

#### **Antitrust Notice**

The information contain herein is in full compliance with the GSM Association's antitrust compliance policy.

## Table of Contents

<b>1</b>	<b>Introduction</b>	<b>4</b>
1.1	Abbreviations	4
1.2	References	5
<b>2</b>	<b>General presentation of LBS</b>	<b>5</b>
2.1	Basic operations for LBS	5
2.2	Access to LBS	6
2.3	Architecture	6
2.4	LBS categories	7
2.5	Terms and parties used in LBS roaming and interworking guidelines	8
<b>3</b>	<b>General Roaming and Interworking Description</b>	<b>10</b>
3.1	General roaming issue	10
3.2	Assumptions	11
3.3	LBS categories and scenarios	12
3.4	Basic roaming and interworking cases	12
3.4.1	Case 1: HPLMN roaming	12
3.4.2	Case 2: VPLMN roaming	13
3.4.3	Case 1: HPLMN roaming	14
3.4.4	Case 2: VPLMN roaming	15
3.4.5	Case 1: Inter-operator Location Service request initiated by a third party SP&CP	15
3.4.6	Case 2: Inter-operator Location Service request initiated by the network	16
<b>4</b>	<b>Roaming Interfaces and Protocols</b>	<b>17</b>
4.1	Ls interface	17
4.2	Lb interface	17
4.3	Le interface	17
4.4	Lh interface	19
4.5	Lg interface	19
4.6	Gr interface	19
4.7	LBS gateway access interface	19
4.7.1	SMS based access	19
4.7.2	WAP/Portal based access	19
4.7.3	Voice based access	20
4.7.4	MMS based access	20
4.7.5	USSD based access	20
4.8	Lc interface	21
<b>5</b>	<b>Location Service parameters</b>	<b>21</b>
5.1	Messages:	21
5.2	Parameters :	21
<b>6</b>	<b>Positioning methods</b>	<b>22</b>
<b>7</b>	<b>Mediation Device, Opaque ID and Alias management</b>	<b>22</b>
<b>8</b>	<b>SMLC</b>	<b>22</b>
<b>9</b>	<b>GMLC</b>	<b>22</b>

<b>10 Service and Content Provider</b>	<b>22</b>
<b>11 Testing strategy</b>	<b>23</b>
11.1 Prerequisites	23
11.2 Features to be tested in roaming and interworking	23
11.3 Testing method	24
11.4 Strategy	24
<b>12 Topics for future study</b>	<b>24</b>
<b>13 Information Exchange For LBS Roaming and interworking</b>	<b>25</b>
<b>Annex A Document Management</b>	<b>26</b>
A.1 Document History	26
A.2 Other Information	26

## 1 Introduction

This document aims to provide a standardised view on how a mobile network supporting Location Based Services (LBS) can deliver the service to outbound roaming customers and to inbound mobile roamers from other network.

Interworking between two mobile networks supporting LBS enabling functionality is also considered to take into account some inter-operator LBS related operations.

The document describes the interworking between networks for the configurations in order to provide:

- LBS roaming capabilities when users roam onto foreign networks
- LBS roaming capabilities for inbound roamers
- LBS interworking capabilities in cases of inter-operator Location Service request; the LBS users may be, in these cases located on their home networks or roaming.

The document will make references to current 3GPP specifications for LBS and to GSM Association document (SERG and BARG) where necessary.

This document meant to provide guidelines for LBS roaming and interworking should be used in conjunction with an additional IREG LBS document PRD for testing purpose.

Billing and regulatory issues are out of the scope of this document.

Also are out of the scope located customer data privacy issue and security issues.

### 1.1 Abbreviations

Term	Description
CP	Content Provider
GMLC	Gateway Mobile Location Centre
GPRS	General Packet Radio Services
GSM	Global System for Mobile communication
HLR	Home Location Register
HPLMN	Home Public Mobile Network
IMSI	International Mobile Subscriber Identity
ISDN	Integrated Services Digital Network
LCS	Location Services
MD	Mediation Device
MLC	Mobile Location Centre
MMS	Multimedia Message Service
MS	Mobile Station
MSC	Mobile-services Switching Centre
MS-ISDN	Mobile Station Integrated Services Digital Network number
PLMN	Public Land Mobile Network

Term	Description
PMN	Public Mobile Network
PRD	Public Reference Document
PSTN	Public Switched Telephone Network
SMLC	Serving Mobile Location Centre
SP	Service Provider
VLR	Visitor Location Register
VMSC	Visited Mobile services Switching Centre
VPLMN	Visited Public Mobile Network
WAP	Wireless Application Protocol
MO-LR	Mobile Originated Location Request
MT-LR	Mobile Terminated Location Request
LIF	LBS Interoperability Forum

## 1.2 References

Ref	Doc Number	Title
[1]	GSM 03.71 version 8.0.0 Release	LCS Functional description - Stage 2, ETSI.
[2]	3G TS 23.271 version 400 Release 4	LCS Stage 2, 3GPP
[3]	PRD SE.23	Location Based Services
[4]	IREG Doc 079/02	Reply to Liaison Statement on use of IP as transport for the Inter-GMLC Interface

## 2 General presentation of LBS

### 2.1 Basic operations for LBS

To provide a Location Based Service related to a mobile subscriber, who is to be located, it is necessary to obtain subscriber location in a mobile network and to utilise this location information to deliver a value added service to the beneficiary of the service.

Following basic operations are used to provide Location Based Services:

- service request by a mobile subscriber. The request is sent to a Service Provider through a Value Added Service supporting system. This request is only applicable to subscriber initiated LBS request.
- location request by the Service Provider in order to get geographical information related to a mobile subscriber. The request is sent to a network element called GMLC. This operation is mandatory.

- Positioning request by the GMLC in order to get location information on a mobile subscriber currently located in a network. The request is sent to a network element called SMLC supporting a Positioning Function.
- Evaluation of location information with the conjunction of measurement functionality in mobile network or elsewhere (e.g. GPS), by the SMLC
- Position delivery by SMLC to GMLC
- geographical information delivery by GMLC to the service provider (?)
- Value added service delivery by the service provider to the end user.

Additional operations regarding data privacy preservation, authentication and permission verification may be performed. Seeking after a mobile subscriber's permission to be located may depend on a given LBS service logic.

## 2.2 Access to LBS

Location Based Services are offered to subscribers using GSM or GPRS networks. The way the customer will access through a network to a particular LBS is not standardised. Basically, end user may access to LBS using Circuit Switched technology or Packet Switched technology (GPRS). Voice, Circuit Switched Data or SMS are possible bearers enabling access to LBS. Only implementation of LBS in a network determines the way the service is delivered to end-users. Regardless of the media used to access the service, generic reference will be made to "**LBS Gateway**" to designate the network function assuming the interface with the end user. For instance, if access to LBS is done using SMS, the LBS Gateway will include the SMS-C and a service provider connected to the SMS-C.

Access to "**LBS Gateway**" applies to:

- Location Based Service request by the end user
- Location Based Service delivery to the end user
- Request for permission to be located to the end user and response of the latter.

## 2.3 Architecture

Location Based Services had been specified in GSM 03.71 [1]. The LBS logical architecture is shown in **Error! Reference source not found.**. The LBS package includes:

- The **Gateway Mobile Location Centre (GMLC)**, the first node a LCS client accesses in a GSM network. The Le interface is used for dialog with LCS client and external network (in case of interworking). The Lh interface is used by the GMLC to request routing information from the HLR. After performing registration and authorisation, it sends positioning requests to and receives final location estimates from the VMSC via the Lg interface.
- The GMLC is specified by 3GPP standards.
- The **Mediation Device (MD)**, responsible for the encryption and decryption of the MSISDN into an opaque ID in order to preserve privacy. Opaque ID is a unique identification of a MSISDN. It could also be responsible for consulting a database in which has been recorded the subscriber's agreement that Location information may be released.
- The MD is not specified by 3GPP standards.

- The **Serving Mobile Location Centre (SMLC)** with its Positioning Function is a combination of network entities that accepts an MSISDN, and returns the latitude and longitude of the mobile. It is capable of establishing dialogue with the HLR and with the SMLC of the inbound roamer's Home network. The implementation of the Positioning Function may vary by Operator and is not standardised.

Besides, **Content Providers & Service providers (SP & CP)** are needed to offer value added services to end users. Service logic, user interfaces for services, interfaces between LBS and Network Operator systems are under Service Providers responsibility. Content Providers offer data to the service.

#### Operator A

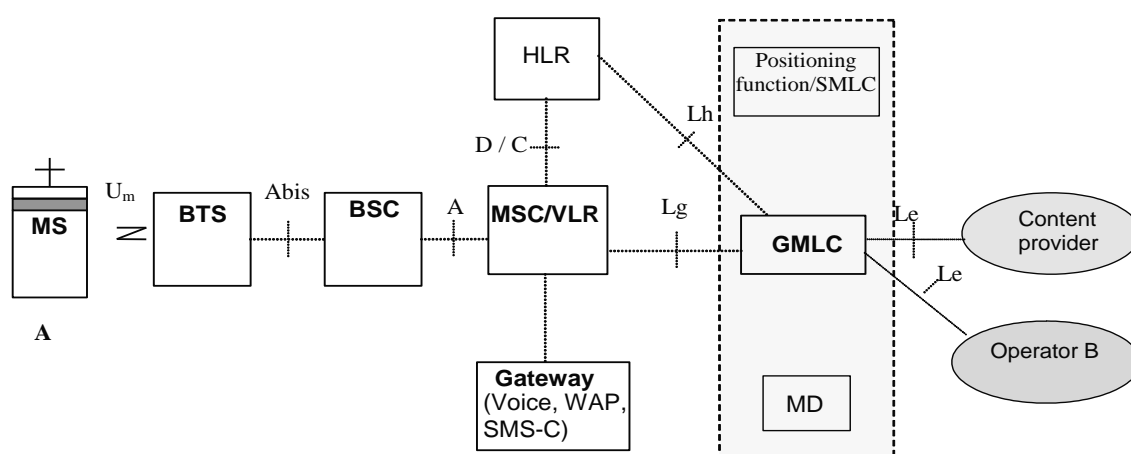

**Figure 1: Overview of the LBS Logical Architecture**

The architecture only describes GSM based access to LBS. Alternative access is GPRS based and is not explicitly described in this document to simplify the presentation.

Standards related issues are still pending and are reported later on in this document.

## 2.4 LBS categories

LBS may be categorised into three types:

- **Pull** service, where the customer makes a location request on per call or packet session basis. The location information is related to this LBS customer who is also the beneficiary of the service. Only one mobile customer is involved in a Pull service session.
- **Push** service, where the location request is made by a service provider, provided that the LBS customer had prior registration to the given push service. The location information is related to this registered LBS customer who is also the beneficiary of the service. Only one mobile customer is involved in a Push service session.
- **Track** service, where either a LBS customer or a server requests a mobile user's position. In this case, the latter is not the beneficiary of the service. For a given Track service session, more than one mobile customer are involved.

## 2.5 Terms and parties used in LBS roaming and interworking guidelines

- **Call Related:** Any LBS related operation which is associated with an established call in CS domain and a session via an active PDP context in PS domain.
- **Interconnection:** The term Interconnection refers to the technical physical connection between two networks.
- **Inter-working** is the functionality of two networks to talk to each.
- other enabling services to be delivered across the two networks.
- **LCS (LoCation Services):** LCS is a service concept in system (e.g. GSM or UMTS) standardisation. LCS specifies all the necessary network elements and entities, their functionalities, interfaces, as well as communication messages, due to implement the positioning functionality in a cellular network. LCS does not specify any location based (value added) services
- **LCS Client:** a software and/or hardware entity that interacts with a LCS Server for the purpose of obtaining location information for one or more Mobile Stations. LCS Clients subscribe to LCS in order to obtain location information. LCS Clients may or may not interact with human users. The LCS Client is responsible for formatting and presenting data and managing the user interface (dialogue). The LCS Client may reside in the Mobile Station (MS)
- **LCS Server:** a software and/or hardware entity offering LCS capabilities. The LCS Server accepts requests, services requests, and sends back responses to the received requests. The LCS server consists of LCS components, which are distributed to one or more PLMN and/or service provider
- **Local LBS roaming:** LBS which can be provided in the current serving network by a Value added Service Provider, using local LBS Gateway
- **Home LBS roaming:** LBS which can be provided in the home network by a Value added Service Provider, using HPLMN LBS Gateway
- **Location Based Service (LBS):** a service provided either by teleoperator or a 3<sup>rd</sup> party service provider that utilises the available location information of the terminal. Location Application offers the User Interface for the service.
- **LBS environment:** term to designate the LBS package including GMLC, MD, SMLC/PF and SP&CP.
- **Positioning:** functionality, which detects a geographical location of a mobile terminal
- **Positioning method:** a principle and/or algorithm to evaluate the estimation of geographical location.
- **Requesting customer (or application) :** a mobile customer (or an application) having made a request for a Pull service, a Push service or for the location of mobile subscriber (Track service). This requesting customer (or application) will get a LBS content as a result of the location service request.
- **Target subscriber:** mobile subscriber being positioned.
- **Tracked subscriber :** a mobile subscriber whose location is requested in case of a track service. Tracked subscriber is a particular case of target subscriber.
- **Roaming Location Based Services:** situation where a target subscriber is roaming onto a visited network. The customer may be:
  - the requesting customer
  - or subject to be positioned.



- **Local LBS Roaming:** situation where the LBS subscriber gets access to the Location based Service through the visited network LBS Gateway.
- **Home LBS Roaming:** situation where the LBS subscriber gets access to the Location based Service through the Home network LBS Gateway.
- **Interworking Location Based Services:** situation where occurs Inter-operator Location Service related operation. Inter-operator data exchange may occur between SP&CP and GMLC or between two GMLC.
- **Location related operations:** operations necessary to locate a mobile subscriber:
  - location request for a mobile subscriber
  - positioning request of a mobile subscriber.
- **LBS customer:** mobile subscriber involved in LBS. It may be either the requesting customer or the target customer. The LBS customer's agreement to be located and to provide this location information to a 3<sup>rd</sup> party may have been registered in the Mediation Device prior to any service request. For some services, a call related authorisation may be performed.
- The LBS customer shall get registration in the MD for authentication and opaque Id allocation and in the Service & Content server to get benefit from the service.
- If need be, extension of LBS subscription to interworking and roaming situations shall be made in relevant servers.
- **Service Provider and Content Provider (SP&CP):** given the scope of the LBS roaming and interworking guidelines, there is no need to distinguish Service Provider and Content Provider. They will be considered as one entity, responsible for the high level service content. SP&CP may or may not have contract with the LBS customer's home network.
- **LBS Gateway** function: seen as a macro-function, regardless of specific implementation retained to access the LBS provider. Basically, access to LBS may be achieved using SMS, WAP gateway, Portal or dedicated voice platform.
- Requesting GMLC: is the GMLC, which receives the request from LCS client
- The "Visited GMLC" is the GMLC, which is associated with the serving node of the target mobile.
- The "Home GMLC" is the GMLC, which is responsible to control the privacy checking of the target mobile.

Following terms will be used in this document to designate LBS related actors.

- MS1(a): LBS subscriber from PLMN(a) for a PULL service
- MS2(a): LBS subscriber from PLMN(a) for a PUSH service
- MS3(a): requesting subscriber from PLMN(a) for a TRACK service
- MS4(b): target subscriber from PLMN(b) for a TRACK service
- SP&CP(a): Service Provider and Content Provider having contract with PLMN(a)
- SP&CP(a,b): Service Provider and Content Provider having contract with PLMN(a) and PLMN(b)

- GMLC(a): GMLC in PLMN(a)
- GMLC(b): GMLC in PLMN(b)
- SMLC(a): SMLC in PLMN(a)
- SMLC(b): SMLC in PLMN(b)

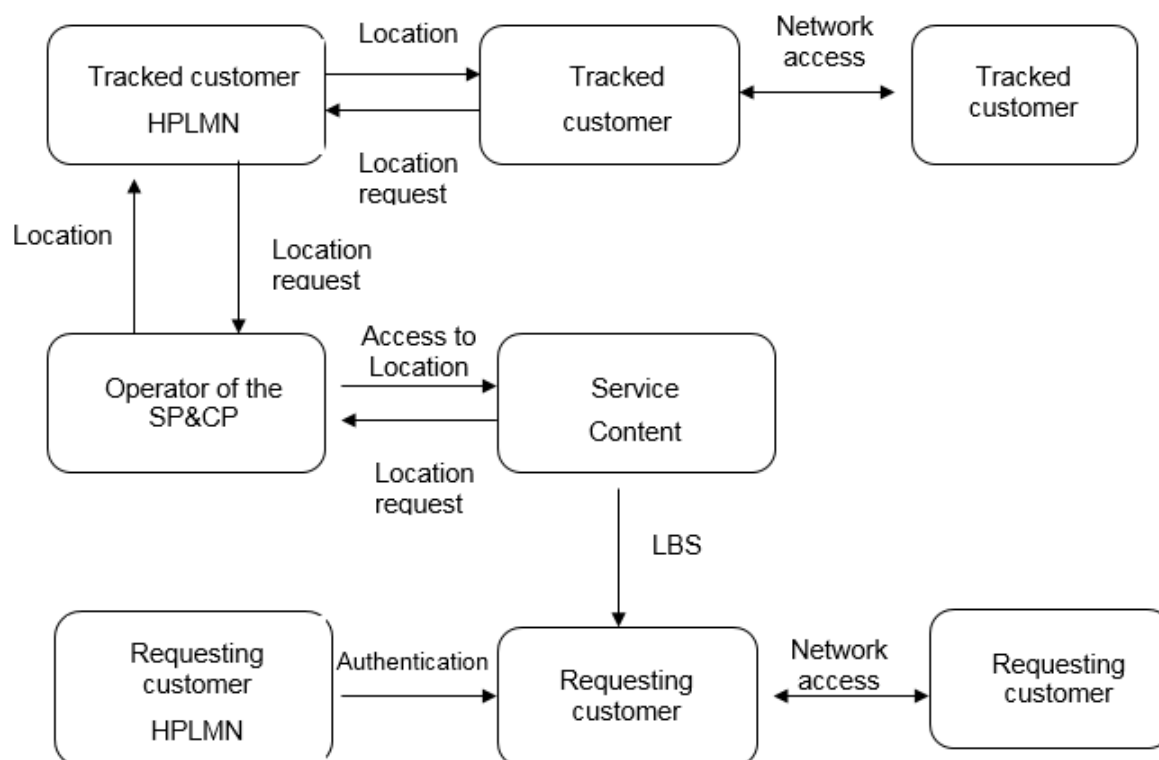

Figure 2: Parties involved in a roaming or interworking LBS

### 3 General Roaming and Interworking Description

#### 3.1 General roaming issue

Basically, LBS may be described with the use of three components:

- SERVICES related to end-to-end specific applications effectively sold to the customer
- FEATURES referring to sets of capabilities (i.e. Mediation Device, Position Server)
- ENABLERS including generic network and terminal functionality including protocols and application interfaces, for the basic transport and control mechanisms (i.e. SMS, WAP, Circuit Switched Channel, Packet Switched Channel).

To assure that any location-based service can be available across boundaries of network operators in the roaming and interworking cases, interoperability need to be defined for each service.

Interoperability at Enablers level will be within reach given their compliance to standards. Interoperability at the Features and Services level might be critical due to specific implementation at network or provider level. Moreover, the roaming of Location Based Services is more complicated than the roaming of voice calls and SMS due to many parties and equipment involved.

Therefore, end to end tests are the only way to assure interoperability and roaming for LBS.

### **3.2 Assumptions**

Given the complexity of LBS roaming and interworking, and given that standardisation only covers Enablers level, it is assumed for the time being to deal with macro-function whenever it comes to describe LBS related operations. This approach gives a certain amount of latitude for specific implementation in networks (e.g. encryption process, authentication process, positioning method).

However, a particular operation having significant impact on roaming or interworking situation may be taken into account for further study. This may be the case for instance for positioning methods requiring data exchange between networks.

Following assumptions are made to describe LBS related call scenarios and might be modified later on:

- Even though LBS may be accessed over GSM and GPRS networks, description in this document is only done using GSM technology .
- The whole authentication process with regard to MD is expected to be handled within the Home network and might be operator specific. Therefore, it is not taken into account in this document. This process will be referred to as a generic process between GMLC and MD at one hand and LBS Gateway and MD on the other. This process may or may not include explicit request to the target subscriber to get the authorisation.
- The way the encryption /decryption is performed is also left outside this document. This part of the process will be referred to as a generic approach
- SMLC and Positioning Function will be referred to as a single entity, assuming the operation of positioning of the target subscriber, regardless of methods effectively implemented. Depending on work progress on SMLC standardisation, modification may be done on this assumption.
- No particular positioning method or technology is taken into account here. Refer to SE23 for details on basic, enhanced or advanced method.
- However, it is assumed that all positioning methods begin with an interrogation of the HLR to find out the currently used network. This HLR interrogation will not be explicitly mentioned in the various use cases and assumed to be implicit in any positioning method
- If a particular positioning method has significant impact on inter-operator information exchange, the topic is to be taken on for further study.

### 3.3 LBS categories and scenarios

LBS category	Request by	Target subscriber	Type of request	Applicable scenario
Pull	MS1(a)	MS1(a)	Call related request	Roaming using Home LBS environment Roaming using local LBS environment
Push	MS2(a)	MS2(a)	Subscription basis	Roaming using HPLMN LBS environment Roaming using VPLMN LBS environment
Track	MS3(a)	MS4(b)	Call related request	inter-operator Location Service request initiated by SP&CP inter-operator Location Service request initiated by network

### 3.4 Basic roaming and interworking cases

A LBS customer may use the Home network LBS environment or a visited network environment, depending on the type of roaming offered to the roamer on GSM or GPRS.

Use case description is done with respect to the three LBS categories (Pull, Push and track services).

- Pull service

#### 3.4.1 Case 1: HPLMN roaming

For MS1(a) roaming onto VPLMN(b), access to the SP&CP(a) is done using the HPLMN(a) LBS Gateway and GMLC(a). The roaming connection between the visited network element and the Home LBS Gateway depends on the media used (voice, SMS, GPRS).

The positioning phase of MS1(a) by SMLC(b) will imply inter-operator LBS operation (positioning phase); interworking between GMLCs will take place.

**Figure 3: Call flow for Pull service with Home LBS roaming**

### 3.4.2 Case 2: VPLMN roaming

In this case, MS1(a) will access to the SP&CP(b) through VPLMN(b) LBS Gateway and GMLC(b). There is no need for roaming leg (call related, SMS related or GPRS session related leg).

The positioning phase of MS1(a) by SMLC(b) will imply inter-operator LBS operation (authorisation phase); interworking between GMLCs will take place.

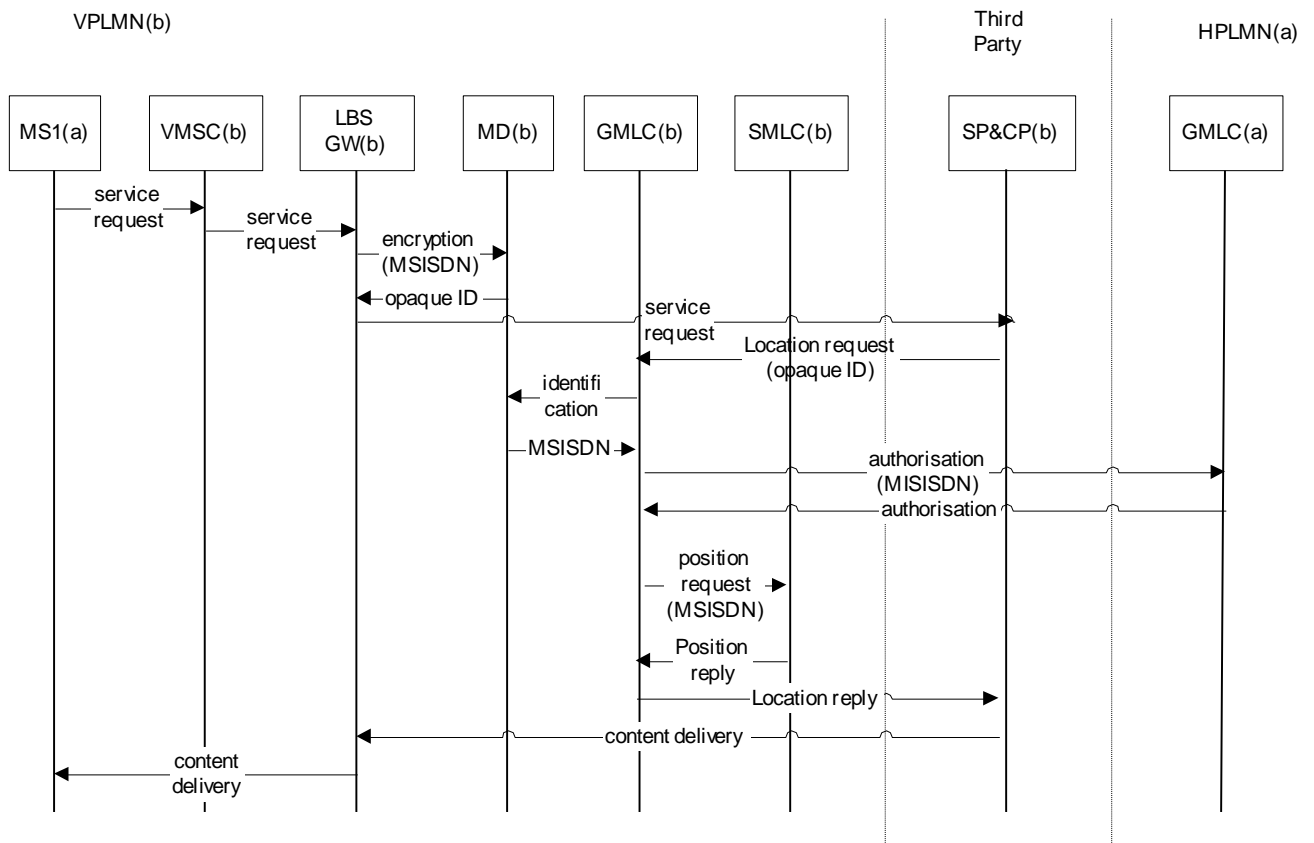

Figure 4: Call flow for Pull service with local LBS roaming

- Push service

### 3.4.3 Case 1: HPLMN roaming

SP&CP(a) will reach MS2(a) roaming onto VPLMN(b) using GMLC(a), HPLMN(a) LBS Gateway and the roaming leg. The roaming connection between the visited network element and the Home LBS Gateway depends on the media used (voice, SMS, GPRS).

The positioning phase of MS2(a) by SMLC(b) will imply inter-operator LBS operation.

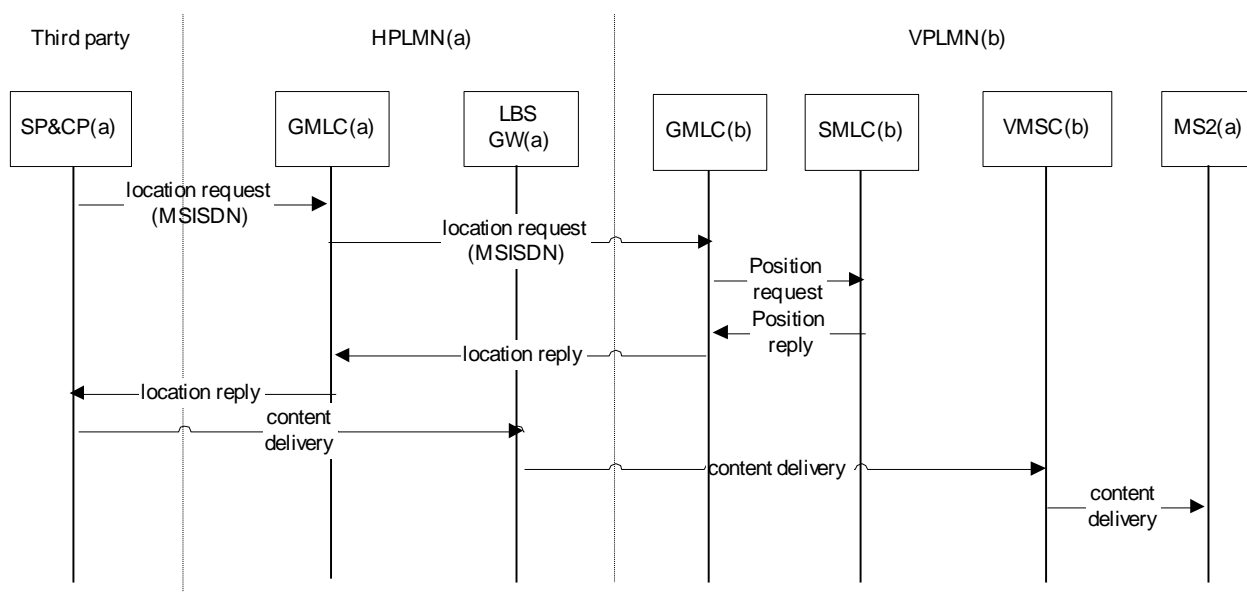
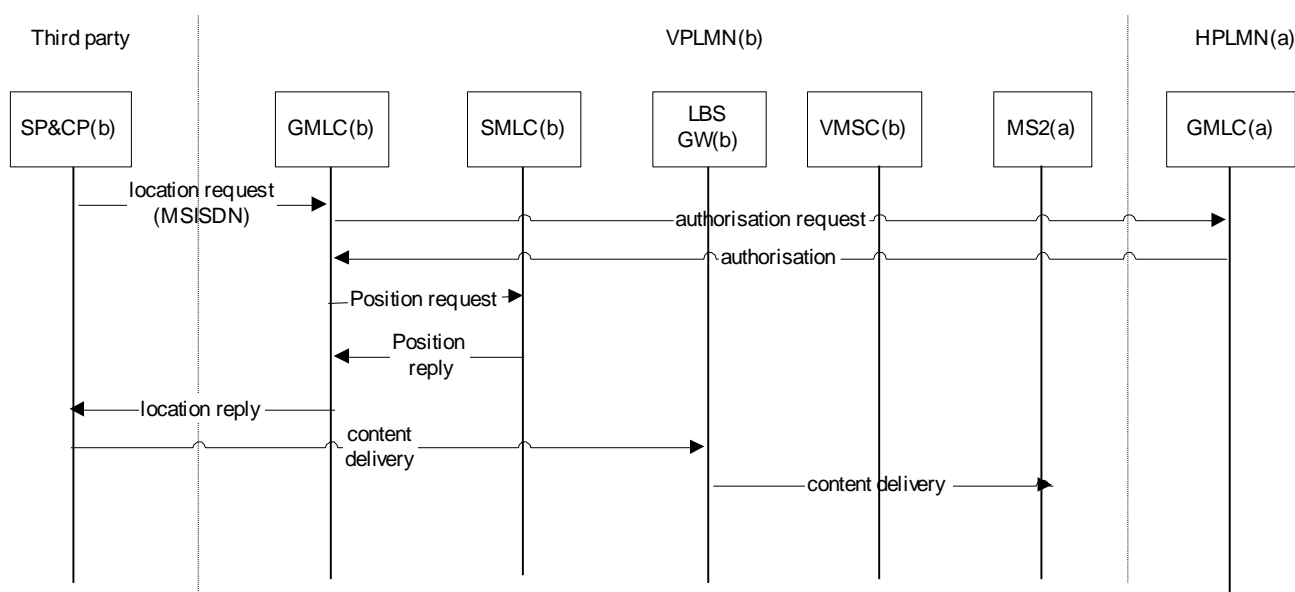

Figure 5: Call flow for Push service with Home LBS roaming

### 3.4.4 Case 2: VPLMN roaming

In this case, MS2(a) is supposed to have registered to a service run by SP&CP(b). The access to the LBS customer will be done through VPLMN(b) LBS Gateway and GMLC(b). There is no need for roaming leg(call related, SMS related or GPRS session related leg).

The positioning phase of MS2(a) by SMLC(b) may require inter-operator dialogue for authorisation seeking.



**Figure 6: Call flow for Push service with Local LBS roaming**

- Track service

To simplify the configuration, only the case of subscribers using their Home network will be studied.

If MS3(a) is roaming onto a network, the requesting phase for a roaming Pull service customer will apply.

If MS4(b) is roaming onto a network, positioning phase for a roaming LBS customer will apply.

### 3.4.5 Case 1: Inter-operator Location Service request initiated by a third party SP&CP

- SP&CP(a,b) is supposed to have contract with both operators.
- MS3(a) is acting as a requesting customer and MS4(b) is the target customer whose position is wanted by MS3(a) through SP&CP(a,b).
- MS3(a) will access the SP&CP(a,b) through the HPLMN(a) LBS Gateway and GMLC(a).

- The positioning phase of MS4(b) will be handled by the SP&CP(a,b) and inter-operator LBS operation (positioning phase) will occur between the SP&CP(a,b) and GMLC(b).

**3.4.6 Case 2: Inter-operator Location Service request initiated by the network**

- MS3(a) is acting as a requesting customer and MS4(b) is the target customer whose position is wanted by MS3(a) through SP&CP(a).
- MS3(a) will access the SP&CP(a) through the HPLMN(a) LBS Gateway and GMLC(a).
- The positioning phase of MS4(b) will be handled by GMLC(a) and inter-operator LBS operation (positioning phase) will occur between GMLC(a) and GMLC(b).

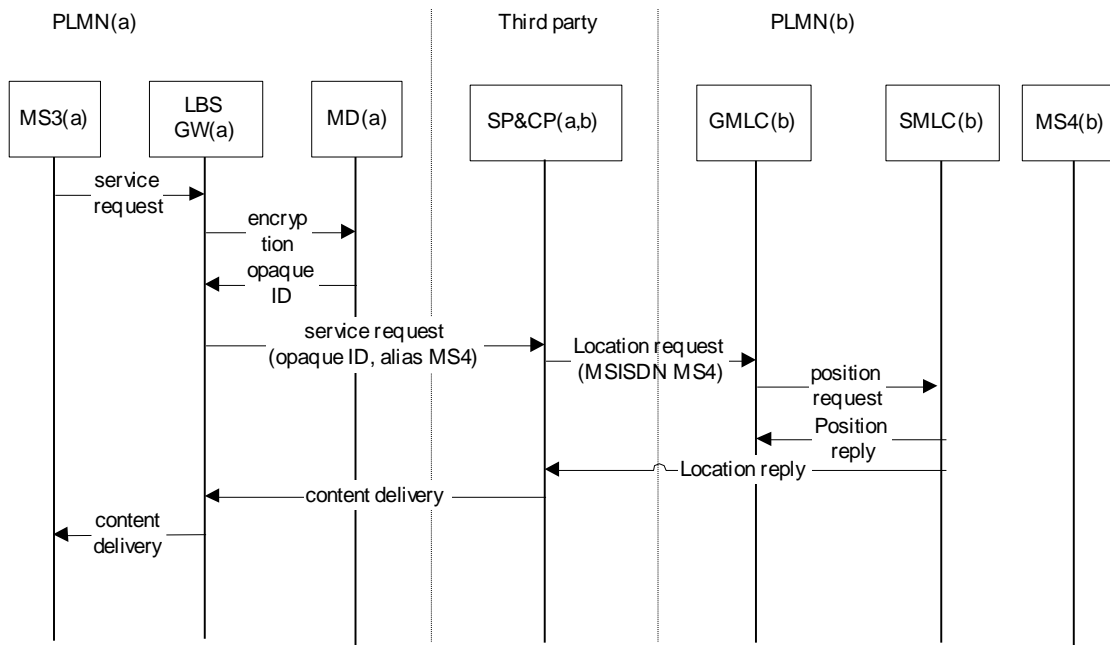

**Figure 7: Call flow for inter-operator Location Service request using SP&CP**



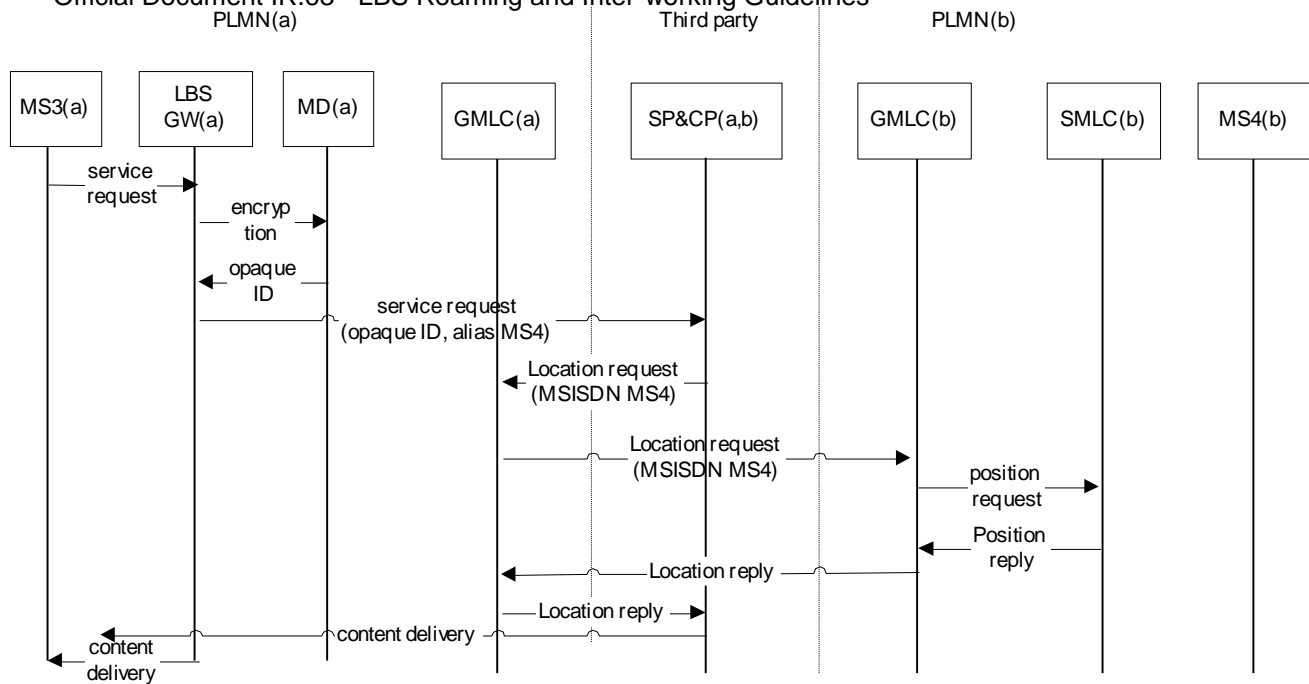

Figure 8: Call flow for inter-operator Location Service request using GMLC

## 4 Roaming Interfaces and Protocols

All the LBS interfaces are standardised in the ETSI GSM recommendations.

### 4.1 Ls interface

This interface is applicable between MSC and SMLC and is used for NSS based SMLC.

### 4.2 Lb interface

This interface is applicable between MSC and SMLC and is used for BNSS based SMLC.

### 4.3 Le interface

Le interface, introduced for Location Based Services applies to GMLC. The use of this interface in roaming or interworking configurations is described below .

#### a) Between GMLC(a) and GMLC(b)

As stated in document [4], the inter-GMLC interface renamed after “Lr” in 3GPP Rel 6, standardisation work is ongoing regarding this interface. Different and operator specific solutions may exist in the early stage of LBS implementation in networks, likely to raise interoperability issue.

Operations at this interface are summarised in the table below.

Operation	Originating entity	Recipient entity	Contents
Location request	GMLC(a)	GMLC(b)	MSISDN
Location result	GMLC(b)	GMLC(a)	Location information (*)
Authorisation request	GMLC(b)	GMLC(a)	MSISDN
Authorisation result	GMLC(a)	GMLC(b)	Authorisation information (**)

NOTE: the nature of this information is to be specified. Geographical co-ordinates (latitude and longitude) may be used.

NOTE: the nature of this information is to be specified.

a) Between GMLC(a) and SP&CP(a)

This interface not being standardised, various solutions may be implemented, expectedly assuring LBS related operations between the two nodes.

Operations at this interface are summarised in the table below.

b) Between GMLC(b) and SP&CP(a)

Assuming that operator(b) and SP&CP(a) have service contract, interoperability issue is unlikely. If GMLC(a) and GMLC(b) are supporting different protocols, the Service Provider is expected to assure interoperability.

Operations at this interface are summarised in the table below.

Operation	Originating entity	Recipient entity	Contents
Location request	SP&CP(a)	GMLC(a) or GMLC(b)	MSISDN
Location result	GMLC(a) or GMLC(b)	SP&CP(a)	Location information (*)

NOTE: the nature of this information is to be specified.

The protocol used at this interface is to be specified with regard to standardisation work progress.

#### 4.4 Lh interface

This interface applies between GMLC(a) and HLR(a). The request for routing information for a mobile subscriber may be done using MAP\_Send\_Routing\_Info\_for\_SM message.

Operation	Originating entity	Recipient entity	Contents
Send_Routing_Info_for_LCS request	GMLC(a)	HLR(a)	MSISDN
Send_Routing_Info_for_LCS result	HLR(a)	GMLC(a)	VLR address

#### 4.5 Lg interface

This interface applies between GMLC and MSC. Various interrogation protocols may be used, eg MAP ATI (AnyTime Interrogation), PSL (Provide Subscriber Location) and also the standardised MAP LCS extensions.

#### 4.6 Gr interface

The Gr interface is yet to be defined in order to offer location information between HLR and SGSN in a standardised way also in GPRS networks.

This part is to be taken on for future study.

#### 4.7 LBS gateway access interface

In this chapter, are given for information purpose some access methods by the end user to Location Based Services. Alternative methods may exist.

These methods are applicable to Pull, Push and Track services.

For a given type of service (Pull, Push and Track), one or more methods may be used.

##### 4.7.1 SMS based access

- Service requesting phase

The LBS customer may access to the Service Provider by sending a SMS. The address of the SMS-C, the recipient entity and the text are service dependant.

- Permission to be located may be requested to the LBS customer using SMS.
- Service delivery phase

The delivery of the service may be performed by the SP&CP with the use of a SMS sent with relevant content to the end user.

##### 4.7.2 WAP/Portal based access

- Service requesting phase

The LBS customer may access to the Service Provider using a WAP or Portal based service. The procedure for his access is service dependant.

- Service delivery phase

The LBS content may be delivered by the SP&CP to the end user through the WAP or Portal provided a connection is already established.

- Permission seeking phase

Permission to be located may be requested to the LBS customer using the WAP or Portal provided a connection is already established.

#### **4.7.3 Voice based access**

- Service requesting phase

The LBS customer may access to the Service Provider by using an IVR. The number to use and the procedure are service dependant.

- Service delivery phase

The delivery of the service to the end user may be performed by the SP&CP using an existing active communication with an IVR.

- Permission seeking phase

Permission to be located may be requested to the LBS customer during an existing active communication with an IVR.

#### **4.7.4 MMS based access**

- Service requesting phase

The LBS customer may access to the Service Provider by sending an MMS. The address of the MMS-C, the recipient entity and the content are service dependant.

- Service delivery phase

The delivery of the service may be performed by the SP&CP with the use of a MMS sent with relevant content to the end user.

#### **4.7.5 USSD based access**

- Service requesting phase

The LBS customer may access to the Service Provider by using an USSD call. The USSD prefix and the procedure are service dependant.

- Service delivery phase

The delivery of the service may be performed by the SP&CP during an existing active communication established using USSD.

## 4.8 Lc interface

The Lc interface supports CAMEL access to LCS and is applicable only in CAMEL phase 3. This section is left for future study.

## 5 Location Service parameters

This chapter provides information on LBS related messages and parameters. This section is to be completed with latest standards.

### 5.1 Messages:

- SEND-ROUTING-INFO-FOR-LCS
- PROVIDE-SUBSCRIBER-LOCATION
- SUBSCRIBER-LOCATION-REPORT

### 5.2 Parameters :

- Location information:
  - Location number
  - Cell ID
  - Geographical information
  - VLR number
  - Age of location information
- Age of Location Estimate: indication of how long ago the location estimate was obtained.
- LCS Client ID: identity of an LCS client
- LCS MLC Data: identities of any authorised GMLCs for a target MS. Only these GMLCs are allowed to send a location request for an external client when location requests are restricted to these GMLCs.
- LCS Priority: priority of the location request
  - LCS QoS: Quality of Service (QoS) for any location request with following elements
    - Response Time : category of response time – “low delay” or “delay tolerant”
    - Horizontal Accuracy: required horizontal accuracy of the location estimate
    - Vertical Coordinate: required vertical coordinate
    - Vertical Accuracy: required vertical accuracy of the location estimate (optional)
- Location Estimate: estimate of the location of an MS in universal coordinates and the accuracy of the estimate
- Location Type: type of location estimate required by the LCS client. Possible location estimate types include:
  - current location
  - current or last known location
  - initial location for an emergency services call

- Privacy Override: indicates if MS privacy is overridden by the LCS client when the GMLC and VMSC for an MR-LR are in the same country.
- LCS Information: LCS related information with following components:
  - GMLC List: the addresses of all GMLCs allowed to issue a non-call related MT-LR location request
  - LCS Privacy Exception List: classes of LCS Client that are allowed to locate any target subscriber, containing
  - MO-LR (Mobile Originated Location Request) List

## 6 Positioning methods

In this chapter, are listed some basic positioning methods. More information is available in SE23 document [3].

- Basic method
- Enhanced method
- Advanced method

## 7 Mediation Device, Opaque ID and Alias management

To be completed with description and requirement if any for roaming and interworking for further study.

## 8 SMLC

The SMLC manages the overall coordination and scheduling of resources required to perform positioning of a mobile. It also calculates the final location estimate and accuracy.

In the case of roaming LBS subscriber, the SMLC is in the VPLMN.

Two types of SMLC have been specified:

- - NSS based SMLC with support of Ls interface
- - BSS based SMLC with support of Lb interface.

## 9 GMLC

The GMLC is the first node an external LCS client accesses in a GSM PLMN. The GMLC may request routing information from the HLR via the Lh interface. After performing registration authorization, it sends positioning requests to and receives final location estimates from the VMSC via the Lg interface.

## 10 Service and Content Provider

This node is responsible for editing Location Based Value Added service content to the LBS customer.

## 11 Testing strategy

### 11.1 Prerequisites

Location Based Services testing in a roaming and interworking configuration is expected to be performed after successful testing of basic international roaming based on IR24 stage 4.

Depending on the specific implementation of the LBS, following may be required:

- GPRS roaming
- CAMEL roaming
- SMS interworking
- MMS interworking.

Agreement between an operator and a Service Provider is assumed established.

For the case of inter-operator request handled by a SP&CP, the latter shall have an agreement with both operators.

### 11.2 Features to be tested in roaming and interworking

International Roaming tests are usually meant to validate inter-PLMN interface and to verify service logic mechanisms in networks. No particular Value Added Service is supposed to be tested in IREG procedure.

Le interface between GMLC(a) and GMLC(b) on one hand and between GMLC(b) and SP&CP(a) on the other hand are newly introduced for Location Based Services. Testing effort is expected to be concentrated on validating this interface in roaming or interworking configurations.

The Le interface between GMLC(a) and SP&CP(a) is not roaming nor interworking specific. Thus no specific testing effort is needed for it.

On the contrary, data exchange between GMLC(b) and SP&CP(a) only occurs in roaming and interworking situations.

The LBS Gateway access leg is not specific to LBS, whatever method is used to get access to LBS environment in HPLMN or VPLMN. Testing this leg would however be relevant for end to end testing of the service.

Positioning methods do require inter-operator data exchange and eligible to be included in the testing strategy. However, given the assumption earlier made, they may be taken into account for further study. In particular, different positioning methods (basic, enhanced and advanced) may be tested as well as performance like accuracy may then be taken on. Fallback of service when locating methods in the visited network differ from the one supported in the home network is to be included.

In conclusion, suggested testing strategy covers following aspects:

- Service requesting phase by a mobile LBS subscriber MS1(a) while roaming onto a VPLMN(b); the request is made to Home LBS Gateway for a Pull service

- Service requesting phase by a mobile LBS subscriber MS1(a) while roaming onto a VPLMN(b); the request is made to Local LBS Gateway for a Pull service
- Service delivering phase for a mobile LBS subscriber MS2(a) while roaming onto a VPLMN(b); the service is delivered by Home LBS Gateway for a Push service
- Service delivering phase for a mobile LBS subscriber MS2(a) while roaming onto a VPLMN(b); the service is delivered by Local LBS Gateway for a Push service
- For a Track service, service requesting phase by a mobile LBS subscriber MS3(a) located in HPLMN(b) through Home LBS Gateway and Location retrieving phase for the target subscriber MS4(b) in HPLMN(b)

### 11.3 Testing method

To achieve a rather generic testing of Location Based Services in inter- operator relationship, it is advised to use a dedicated application in the network that would simulate a Service Provider. The objective would be to verify inter-operator transport capability regardless of any service content.

This application should be accessed through Le interface and be capable of establishing dialogue with GMLC through national signalling and international networks.

The service logic embedded in this application would be responsible for the following LBS related operations:

- accepting service request from a mobile customer
- triggering a location request for a mobile customer, following an explicit request from a mobile customer
- triggering a location request for a mobile customer, according to predefined schedule
- requesting subscriber authorisation prior to a positioning operation
- delivering LBS related response to the requesting subscriber.

This application may be supported in HPLMN and VPLMN, in order to allow both Home and Local LBS Gateway access.

### 11.4 Strategy

An operator willing to extend LBS offer to roaming and interworking is advised :

- to perform tests using the generic service logic as described earlier
- to perform specific tests which may include for instance a specific service or a specific positioning method on bilateral agreement.

## 12 Topics for future study

Hints are given below for future versions of this document.

- taking into account inter-GMLC interface standard with IP connectivity and security aspects
- inclusion of positioning methods to be tested on roaming situation
- layout of security related aspects (authentication, opaque Id, alias...)



### **13 Information Exchange For LBS Roaming and interworking**

Consequent to the strategy based on implementing a specific test oriented service logic, following procedure is applicable to move on to LBS interworking and roaming testing.

- IR21 will be exchanged
- Test SIM cards will be exchanged
- Test SIM cards will be provisioned with relevant data (GSM and/or GPRS roaming profile, specific data if applicable, in particular)
- LBS interworking and roaming test specification
- Information regarding test service logic

## Annex A Document Management

### A.1 Document History

Version	Date	Brief Description of Change	Approval Authority	Editor / Company
0.0.1	28.11.2002	First draft of document for Signalling#5 group meeting	Networks Group	Javier Sendin GSMA
0.0.2	24.06.2003	Chapters 1.1, 1.2, 1.6, 2.6 and 8 added, chapter 3 modified, message flows completed following group meeting#7	Networks Group	Javier Sendin GSMA
0.0.3	27.07.2003	Document to be presented to Signal meeting#10	Networks Group	Javier Sendin GSMA
1.0.0	August	Approved at Signal WG	Networks Group	Javier Sendin GSMA
2.0.0	August	Approved at IREG #45	Networks Group	Javier Sendin GSMA
3.0.0	December	Approved by EMC and membership	Networks Group/PSMC	Javier Sendin GSMA

### A.2 Other Information

Type	Description
Document Owner	Networks Group
Editor / Company	Jean-Pierre Kobal (Tata Communications Services (Bermuda) Limited)

It is our intention to provide a quality product for your use. If you find any errors or omissions, please contact us with your comments. You may notify us at [prd@gsma.com](mailto:prd@gsma.com)

Your comments or suggestions & questions are always welcome.